

PEOPLE'S DEMOCRATIC REPUBLIC OF ALGERIA

Ministry of Higher Education and Scientific Research

University of Batna 2

Institute of Industrial Health and Safety

Laboratory of Research in Industrial Prevention



A thesis presented

by

ZERROUKI HAMZA

in partial fulfillment of the requirements for the degree of

DOCTOR 3rd Cycle LMD

in the subject of

Industrial Health and Safety

Option: Management of Industrial and Environmental Risks

Contribution to the modeling of industrial processes using Oriented Object Bayesian Networks

Advisory Committee:

Prof. Djebabra Mebarek	Chair	Batna 2 University, Algeria
Dr. Smadi Hacene	Supervisor	Batna 2 University, Algeria
Prof. Serairi Kamel	Examiner	University of Mohamed Khider Biskra, Algeria
Dr. Innal Fares	Examiner	University of 20 August 1955 Skikda, Algeria

2017/2018

To my former supervisor Prof. Tamrabet Abdellah (رحمه الله)

To my parents

To my family

To all my friends

Acknowledgements

First of all, my deepest gratitude goes to the almighty ALLAH, the beneficial, the merciful for granting me to materialize this research in the present form.

In the memory of my former supervisor Prof. Tamrabet Abdellah, who started this thesis with me and unfortunately he was not able to finish it with me. I hope this will make him proud. I am very thankful to him since he guided me to the path of research.

I would like to express my gratitude and respect to my supervisor Dr. Hacene Smadi, who had always been there as a mentor to guide me through all these years. I learned a lot from his vast experience and knowledge. I really appreciate his support.

I am also thankful to my advisory committee members Pr. Mebarek Djebabra, Pr. Kamel Serairi, and Dr. Fares Innal for critical comments and constructive suggestions.

I would like to thank Dr. Eduardo Patelli, who has invited me to his laboratory in the Institute for Risk and Uncertainty in Liverpool (UK) and support me when I was there.

I would like to thank all the professors in the Occupational Health and Safety Institute in Batna 2 University.

My deepest thanks go to my family members; my father, my mother, sisters and brothers for their love and affection during all these years.

Thanks to all my friends especially Amine, Khalil, Nadhir, and Abdelkader for their help and support not only in my research but also in my life.

Contents

List of Figures	iii
List of Tables	v
Abbreviations	vii
1 OVERVIEW ON SAFETY AND RISK CONCEPTS	7
1.1 Definition of basic concepts	7
1.1.1 Risk and Hazard	7
1.1.2 Other concepts associated with risk	7
1.2 Risk analysis, Risk evaluation, Risk assessment, and Risk management . .	11
1.2.1 Risk analysis	11
1.2.2 Risk evaluation	11
1.2.3 Risk Assessment	11
1.2.4 Risk management	12
1.3 Development of Process Safety	12
1.4 Most catastrophic accidents in the last three decades	14
1.4.1 The Ocean Ranger tragedy	15
1.4.2 The Bhopal disaster	16
1.4.3 Sayano–Shushenskaya power station accident	17
1.4.4 Fukushima Daiichi nuclear disaster	17
1.4.5 Deep-water Horizon (the Macondo blowout)	18
1.5 Accident process model	19
1.6 Safety and risk analysis techniques	22
1.6.1 Qualitative approaches	22
1.6.2 Quantitative approaches	24

1.7	Conclusion	30
2	A REVIEW OF BAYESIAN BELIEF NETWORK USED IN PROCESS INDUSTRIES	35
2.1	Introduction	35
2.2	Bayesian Networks technique (BNs)	37
2.3	Collect of Data	38
2.4	Overview on the application of BBN in risk analysis and accident modeling in chemical plants	39
2.4.1	Dynamic Bayesian Networks	48
2.4.2	Oriented Object Bayesian Networks	51
2.5	Risk Analysis of a Case Study Using Bayesian Belief Networks	53
2.5.1	Description of the process	53
2.5.2	Application of the methodology	55
2.5.3	Results and discussion	59
2.6	Conclusion	60
3	RELIABILITY AND SAFETY ANALYSIS USING FAULT TREE AND BAYESIAN NETWORKS	72
3.1	Introduction	72
3.2	Analysis Approach	73
3.2.1	Fault Tree Analysis	73
3.2.2	Bayesian Network technique	74
3.2.3	Mapping FT into BN	77
3.3	Safety Analysis of Steam Boiler System (SBS)	78
3.3.1	Description of the steam boiler system	78
3.3.2	Fault tree analysis	80
3.3.3	Bayesian Network Analysis	82
3.3.4	Sequential learning	88
3.3.5	Conclusion	90
4	RISK ASSESSMENT OF A LIQUEFIED NATURAL GAS PROCESS FACILITY USING BOW-TIE AND BAYESIAN NETWORKS	94
4.1	Introduction	94
4.2	Risk analysis methods	96
4.2.1	Bow-tie technique (BT)	96

4.2.2	Mapping Bow-Tie into Bayesian Networks	99
4.3	Case study	100
4.3.1	Description of the process	100
4.3.2	Bow-Tie analysis	102
4.3.3	Bayesian Networks Analysis	107
4.4	Results and discussion	108
4.5	Conclusion	112
General Conclusion		117
A Appendix		121
A.1	Hugin history	121
A.2	AgenaRisk	121
A.2.1	Types of Modeling in AgenaRisk	122
A.3	Importance of minimal cut-set (IM)	122
Abstract		125

List of Figures

1	World oil demand by main region 2014-2015 (source: Annual Report of OPEC 2015).	2
2	Steps followed to form the review.	4
1.1	Risk analysis, evaluation, assessment, and management (Rausand 2011). . .	12
1.2	Accident trend analysis from 1988 to 2012 (Khan et al. 2015).	13
1.3	Developments in science and engineering relevant to process safety (De Rademaeker et al. 2014).	14
1.4	Houston model of the accident process (Houston 1971).	20
1.5	Fault tree accident model (Khan & Abbasi 1999).	20
1.6	MADS model (Bouloiz et al. 2010).	21
1.7	Accident model that incorporate human, organizational, and external failure (Adedigba et al. 2016).	21
1.8	Event tree for LPG release (Ferdous et al. 2009).	26
1.9	Bayesian network for the reduced car start problem	27
2.1	Example of BN model.	38
2.2	Time distribution of the publications of BBN used in the chemical plants in the last decade	40
2.3	Journal distribution of the publications of BBN used in the chemical plants in the past ten years	41
2.4	Distribution of references that used BN in the chemical plants and process industries (2006-2016).	47
2.5	An illustrative example of dynamic Bayesian network for three variables. . .	49
2.6	An ordinary BN in the left side is constructed using hierarchical structures with arbitrary levels of abstraction in the middle and then presented by instance nodes in the right.	52
2.7	Simplified Process Flow Diagram of the facilities	55

2.8	Event tree for the accident scenarios	57
2.9	Bayesian network model for the accident scenarios	59
3.1	Example of BN model	75
3.2	Example of BN	76
3.3	Evidence $B = b_1$ inserted in the BN	76
3.4	The representation of AND-gate in FT and BN	77
3.5	The representation of OR-gate in FT and BN	78
3.6	Steam Boiler Schematic (Innal et al. 2014)	79
3.7	FT for the Steam Boiler System (Innal et al. 2014)	81
3.8	Example from Hugin software	83
3.9	BN for the Steam Boiler System	84
3.10	Prior and posterior probabilities the basic events	85
3.11	BN with an Alarm and operator	87
3.12	BN with CPTs	88
3.13	Updated probabilities of the Basic event during 5 years of SBS function.	90
4.1	Generic example of a bowtie from de Dianous and Fiévez (2006).	97
4.2	Example of bow-tie model (C; consequence, IE; intermediate event, BE; basic event, CE; critical event, E; event)	99
4.3	Mapping algorithm from BT into BN (Khakzad et al. 2013b)	100
4.4	BN model for the BT example in Fig. 4.2 (C; consequence, IE; intermediate event, BE; basic event, CE; critical event, E; event).	101
4.5	Simplified LNG plant block diagram.	102
4.6	BT for the LNG release accident scenario.	106
4.7	BN of the BT presented in Fig. 4.6.	107
4.8	Prior and posterior probabilities of Safety Barriers.	110
4.9	BN considering the failure of RPB, DPB, and IPB and the success of HFB.	111
4.10	OOBN for Major LNG release	112
4.11	Collapsed form of the OOBN for Major LNG release	112
4.12	BN with discrete variables and continuous variables	119

List of Tables

1.1	Some definitions of risk and hazard	8
1.2	Overview of some of the major accidents in worldwide operations, 1980-2011 (updated from (Vinnem 2014)).	15
1.3	Guide words and their physical significance (derives from (Khan and Abbasi 1998))	23
1.4	Unconditional probabilities for the parent nodes.	28
1.5	Conditional probabilities for the child nodes.	28
1.6	The joint probability table for P (Fu, FM, SP, St = no).	29
1.7	The joint probability table for P (Fu, SP, St = no, FM = $\frac{1}{2}$)	29
2.1	Different review of Chemical Plants and Bayesian Networks in reliability and safety analysis	39
2.2	Literature of Bayesian Belief Network (BBN) method (2006-2016) used in chemical plants and process industries	42
2.3	Extracted HAZOP of the accident scenarios related to the process	56
2.4	CPT of the pressure relief valve HXC102	58
2.5	Different components related to the accident scenarios in the process and their occurrence probabilities.	58
2.6	Frequencies of the consequences.	59
3.1	Unconditional probability table of variable A	76
3.2	Conditional probability table of variable B	76
3.3	Conditional probability table corresponding to AND-gate	77
3.4	My caption	78
3.5	Different events related to an accident scenario in the steam boiler system and their occurrence probabilities.	80

3.6	Events probabilities and improvement factors and improvement index for FT analysis	82
3.7	Minimal cut sets and their importance	82
3.8	Events probabilities and improvement factors and improvement index for BN analysis	86
3.9	Different modeling steps in Bayesian Networks analysis	87
3.10	CPT of Alarm	88
3.11	Accident occurrence during 5 years of SBS function.	89
4.1	A review of bowtie method and its classification according to Ruijter (2015).	98
4.2	Different components and events related to LNG release and their occurrence probabilities	104
4.3	Failure probability of the safety barriers.	105
4.4	Consequences of the Major LNG release accident scenario.	105
4.5	Accident analysis results from both BT and BN techniques.	106
4.6	Diagnostic analysis of the basic events	109
4.7	Diagnostic analysis of the consequences.	109
4.8	Diagnostic analysis of Safety barriers.	110

Abbreviations

BNs	Bayesian networks
BOP	Blowout Preventer
BT	Bow Tie Analysis
CE	Critical Event
CPT	Conditional Probability Table
DAG	Directed Acyclic Graph
DAP	Detergent Alkylate Plant
DBN	Dynamic Bayesian Network
DOOBN	Dynamic Object Oriented Bayesian Networks
DTBN	Discrete Time Bayesian Network
eBN	Enhanced Bayesian Network
ET	Event tree
FBBN	Fuzzy Bayesian Belief Network
FMEA	Failure Mode Effect Analysis
FRAM	Functional Resonance Analysis Method
FTA	Fault Tree Analysis
HAZOP	Hazard and Operability
HBLF	Hierarchical Bayesian Loss Function
Hi-BN	Hierarchical Bayesian Network
Hy-BN	Hybrid Bayesian Network
IE	Initiating Event
IEC	International Electrotechnical Commission
ISM	Interpretive Structural Modeling
ISO	International Organization for Standardization
LNG	Liquefied Natural Gas
LOPA	Layer Of Protection Analysis
LPG	Liquefied Petroleum Gas

MCS	Minimal Cut Sets
MPE	Most Probable Explanation
MTBF	Mean Time Between Failures
MTTR	Mean Time To Repair
OECD	Organization for Economic Co-operation and Development
OOBN	Object Oriented Bayesian Networks
OPEC	Organization of the Petroleum Exporting Countries
P&ID	Process and Instrument Drawing
PFD	Process flow diagram
PFT	Pseudo-Fault Tree
QRA	Quantitative Risk Analysis
SIS	safety instrumented system
TE	Top Event

General Introduction

The big development of nowadays industries leads to rises of new risks that if not handled could cause damage to human life, properties, and the environment. The aforementioned development is a two-edged sword, since it facilitates and provide the goods and services for the individual daily life requirements; on the other hand, it can cause catastrophic accidents with enormous losses. One of the most important industries is the chemical and process plants. These plants are classified as the key role in today's high-tech world since it gathers all the discipline (Mechanical engineering, civil engineering and safety engineering) and deals with high pressure/temperature products. Chemical and process industries cover different kind of manufactory such as food industry, detergents industry, and oil and gas industry, which is the subject of our attention. Figure 1 represent the world demand of oil in 2014/2015 and it is obviously notable the huge need of oil from developed and non-developed countries. Algeria is the fifth largest supplier of the gas to Europe and the tenth to the World; also, it is the seventeenth largest supplier of oil to the World (2016). Moreover, the income of the economy in Algeria depends on 98 % of the oil and gas. Knowing these facts, it is necessary to guaranty the well function and the safety of these plants.

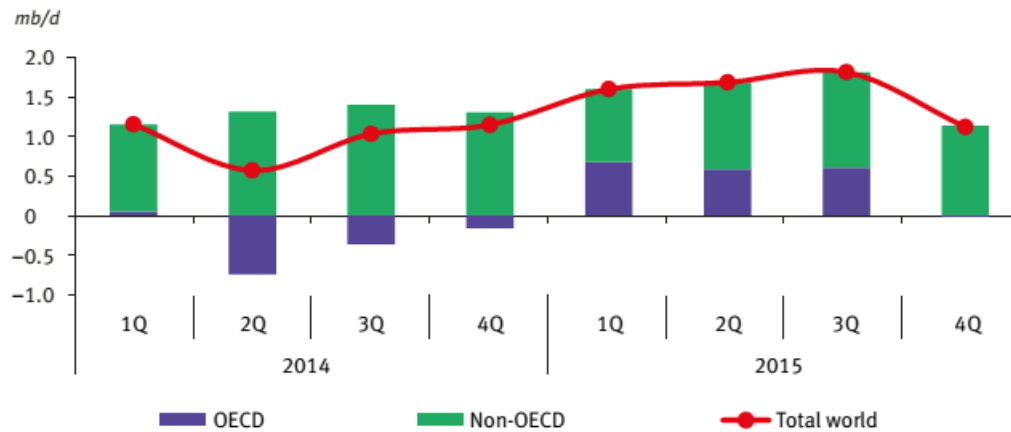

Figure 1: World oil demand by main region 2014-2015 (source: Annual Report of OPEC 2015).

As a result of the rapid growth of industrialization, particularly chemical plants and process industries, the risk posed by different accidents starts to rise highly. The main problems in these industries that they deal with different products, generally dangerous products (i.e. toxic, flammable, and explosive), and at a high level of pressure and temperature. One of the most dangerous sector in these plants is the petrochemical industry (oil and gas product). Even accidents in such industry have a low frequency occurrence; the consequences are catastrophic and caused enormous losses. We still remember the accident occurred in Skikda, Algeria, on 19 January 2004. A very strong explosion occurred at 18:40 at the LNG Liquefaction Complex GL1/K in Skikda, followed by a fire. Three of the six liquefying units in the Complex were severely damaged, and subjected to intense fire. The losses are very high, 23 deaths and 74 injured, without talking about economic losses and environmental pollution.

The need for techniques and methods to analyze the faced risks and to guarantee the required safety within these plants is necessary. The safety engineers along with a group of expert including mechanical engineers, instrumentation engineer and others usually makes this analysis. In the last few decades, several techniques and methods have been proposed and developed for decision-making in safety and risk analysis. Those methods are classified in two main family; Qualitative and Quantitative methods. The qualitative techniques includes method such as Hazard and Operability (HAZOP) analysis, Failure Mode Effect Analysis (FMEA), and What-if analysis. The quantitative ones includes Event tree (ET), Fault Tree (FT), and Bow-Tie Analysis (BT). However, these last methods suffer from some limitations particularly when new information become available about the system studied or when we need to represent the dependencies between different events in the

model.

In the last three decades, researchers used Bayesian networks (BNs) to overcome the aforementioned limitations in the previous methods. The results from the coupled methodology between BNs and the other methods present a robust tool for decision making in safety and risk analysis. Nima Khakzad et al. (Khakzad et al. 2011) compared FT and BN for safety analysis in process facilities. The same authors mapped bow-tie into Bayesian network for dynamic safety analysis of process systems (Khakzad et al. 2013). The last work followed by dozens of publications based on the same principle (Abimbola et al. 2014) (Abimbola et al. 2015) (Zerouali et al. 2016) (Zarei et al. 2017). BNs have proven their efficiency to conduct a safety and risk analysis for complex systems and present a good solution to overcome the limitations in the conventional methods.

The main objectives of this thesis can be summarized in the following points:

- Present a well review on application of Bayesian network in the chemical plants and process industry within the last decade (2006-2016) and present a simple application of Bayesian network in a gas facility;
- Briefly discuss the advantages of Bayesian networks to conduct a safety and risk analysis over the well-known methods Fault tree, Event tree, and Bow-tie;
- Use Bayesian network in the process of risk assessment with an application of Oriented Object Bayesian Network to make the model more tractable and readable in an LNG facility.

Thesis organization

This thesis is organized as follows:

In chapter 1, we will give an entrance about some aspects that are widely used in the safety-engineering domain. In addition, the Development of Process Safety concept is discussed. An accident trend analysis and some recent accidents are investigated. Furthermore, some techniques for safety and risk analysis of process industries are examined.

A brief statistical review of the use of Bayesian networks in the chemical and process industry within the last decade is presented in chapter 2. The review reveals that Bayesian Networks have been used extensively in various forms of safety and risk assessment. This trend is attributable to the complexity of the installations found in this industry and the ability of Bayesian Belief Network "BBN" to intuitively represent these complexities,

handle uncertainties, and update event probabilities. Figure 2 shows the steps followed to build this review and summarizes the important highlights. The chapter is concluded with an illustrative example of the use of BBN to investigate the effectiveness of the safety barriers of a gas facility.

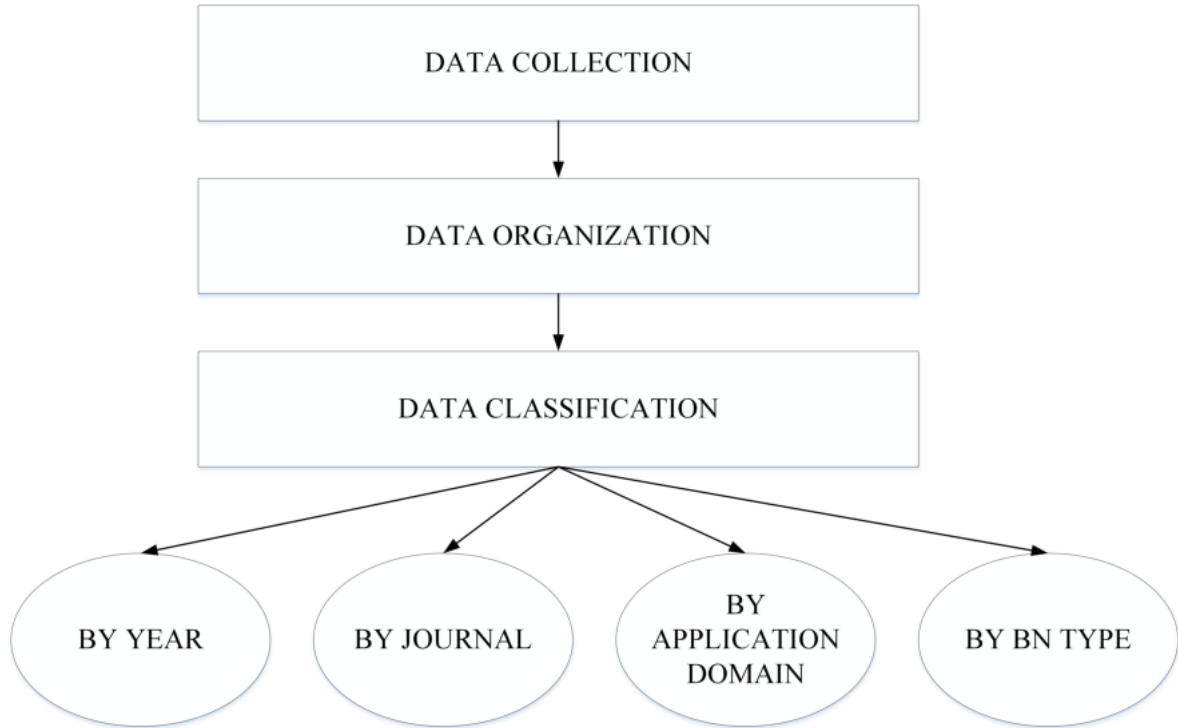

Figure 2: Steps followed to form the review.

Chapter 3 discusses the advantages of Bayesian networks over Fault tree in reliability and safety analysis. In addition, it shows the ability of BN to update probabilities, represent multi-state variables, and dependent failures. Moreover, we will apply probability updating to dynamically update probabilities of the system's components. An example taken from the literature is used to illustrate the application and compare the results of both Fault Tree and Bayesian Networks techniques. Finally, we will use the sequential learning or probability adapting to predict the behaviour of the components in the system during a time interval where the accident occurs several times.

Risk assessment methodology to identify, analyze, and evaluate the risk associated with different consequences of a Liquefied Natural Gas (LNG) process facility from west Algeria is presented in chapter 4. Firstly, the Bow-tie analysis (BT) is used to identify the possible causes of hazardous events and specify the dangerous outcomes consequences resulting from the failure of the safety barriers. Moreover, the bow-tie is mapped into Bayesian networks (BN) to overcome some limitation of dependencies and updating in the

events. Secondly, diagnosis analysis is used to specify the dangerous consequences, which is the objective of risk evaluation. Finally, the risk-reducing measures implemented in the process are examined using Bayesian networks. This latter used diagnostic (posterior) and predictive (prior) analysis to calculate the probabilities of the components and predict the occurrence frequency of the consequences. In addition to the aforementioned steps, we will construct an object-oriented Bayesian network "OOBN" based on the previous model. The constructed OOBN summarizes and abstracts the previous model.

Scientific Contributions

Journal papers

Zerrouki H, Smadi H (2017) Bayesian Belief Network Used in the Chemical and Process Industry: A Review and Application. *J Fail Anal Prev* 17:159–165.

Zerrouki H, Smadi H (2017) Reliability and safety analysis using Fault Tree and Bayesian Networks. *Int J Comput Aided Eng Technol* x:1–14.

International Conference Papers

H. Zerrouki and A. Tamrabet, "Mapping Fault Tree into Bayesian Network in safety analysis of process system", 4th International Conference on Electrical Engineering (ICEE), Boumerdes (Algeria), 2015.

H. Zerrouki and A. Tamrabet, "Fault tree and Bayesian Network in safety analysis: Comparative study", International Conference on Applied Automation and Industrial Diagnostics (ICAAID), Djelfa (Algeria), 2015.

H. Zerrouki and H. Smadi, "Safety and Risk Analysis in Oil and Gas Industry Using Bayesian Networks", International Conference on Bayesian Networks and Applications, Sousse (Tunisia), October 14th-16th, 2016.

H. Zerrouki and H. Smadi, "Fault diagnosis of a Hydrotreater Reactor by using Fault Tree and Bayesian Network" 6th International Conference on Systems and Control, Batna (Algeria), 2017.

H. Zerrouki and H. Smadi, "Risk management of a Liquefied Natural Gas process facility using Bow tie and Bayesian Networks" accepted for oral presentation in the European Safety and Reliability Conference ESREL, Slovenia, 2017.

References

Abimbola M, Khan F, Khakzad N (2014) Dynamic safety risk analysis of offshore drilling. *J Loss Prev Process Ind* 30:74–85. doi: 10.1016/j.jlp.2014.05.002

Abimbola M, Khan F, Khakzad N, Butt S (2015) Safety and risk analysis of managed pressure drilling operation using Bayesian network. *Saf Sci* 76:133–144. doi: 10.1016/j.ssci.2015.01.010

Khakzad N, Khan F, Amyotte P (2011) Safety analysis in process facilities: Comparison of fault tree and Bayesian network approaches. *Reliab Eng Syst Saf* 96:925–932. doi: 10.1016/j.ress.2011.03.012

Khakzad N, Khan F, Amyotte P (2013) Dynamic safety analysis of process systems by mapping bow-tie into Bayesian network. *Process Saf Environ Prot* 91:46–53. doi: 10.1016/j.psep.2012.01.005

Zarei E, Azadeh A, Khakzad N, Aliabadi MM, Mohammadfam I (2017) Dynamic safety assessment of natural gas stations using Bayesian network. *J Hazard Mater* 321:830–840. doi: 10.1016/j.jhazmat.2016.09.074

Zerouali B, Kara M, Hamaidi B (2016) Bayesian Network and Bow Tie to Analyze the Risk of Fire and Explosion of Pipelines. *Process Saf Prog* 25:326–330. doi: 10.1002/prs

Chapter 1

OVERVIEW ON SAFETY AND RISK CONCEPTS

1.1 Definition of basic concepts

In the following, we will try to present a glance about the required concept to go throughout with the rest of chapters. Some of them are axioms, and others are subject to debate. Most of the definitions are quoted from well-known standards and references.

1.1.1 Risk and Hazard

Many definitions of Risk and Hazard can be found in the literature, in Table 1.1, we will summarize some of these definitions:

1.1.2 Other concepts associated with risk

- **incident**

An incident can be defined as an ‘*Event that gave rise to an accident or had the potential to lead to an accident*’(British Standards Institution 2007) or ‘*An unplanned and unforeseen event that may or may not result in harm to one or more assets*’(Rausand 2011).

- **Accident**

An accident is defined in OHSAS 18001 (British Standards Institution 2007) as an ‘*Undesired event giving rise to death, ill health, injury damage or loss*’. According

Table 1.1: Some definitions of risk and hazard

Term	Definition	Reference
<i>Risk</i>	combination of the likelihood of an occurrence of a hazard event or exposure and the severity of injury or ill health that may be caused by the event or exposure	(British Standards Institution 2007)
	a combination of hazard and probability of hazard occurrence	(Khan and Abbasi 1998)
	the combined answer to three questions: (1) What can go wrong? (2) What is the likelihood of that happening? and (3) What are the consequences?	(Rausand 2011)
<i>Chemical risk</i>	a consequence of the presence of hazards	(Reniers 2010)
<i>Hazard</i>	source, situation or act with a potential for harm in terms of human injury or ill health, or a combination of these.	(British Standards Institution 2007)
	the degree of harm to human beings, property, society or environment	(Khan and Abbasi 1998)
	any real or potential condition that can cause injury, illness, or death to personnel; damage to or loss of a system, equipment or property; or damage to the environment.	(MIL-STD-882D 2000)
	a source of danger that may cause harm to an asset.	(Rausand 2011)
<i>Chemical hazard</i>	a set of circumstances that may result in harmful consequences	(Reniers 2010)

to (Rausand 2011) an accident is ‘*A sudden, unwanted, and unplanned event or event sequence that leads to harm to people, the environment, or other assets*’.

- **Safety**

Freedom from those conditions that can cause death, injury, occupational illness, damage to or loss of equipment or property, or damage to the environment (MIL-STD-882D 2000).

- **Hazardous material**

Any substance that, due to its chemical, physical, or biological nature, causes safety, public health, or environmental concerns that would require an elevated level of effort to manage (MIL-STD-882D 2000).

- **Domino effect**

The propagation of a primary accidental event to nearby units, causing their damage and further secondary accidental events resulting in an overall scenario more severe than the primary event that triggered the escalation (Antonioni et al. 2009).

- **Fault**

A fault is an abnormal condition that may cause a deterioration or loss in the capability of a unit to perform a required function (Isermann 2006).

- **Fault detection and fault diagnosis**

These techniques are usually used to detect, evaluate and determine the location and the time of detection of the most possible fault (Isermann 2006).

- **Reliability**

This concept is defined by (ISO 1994) as “*the ability of item (component, subsystem, or system) to perform a required function, under given environmental and operational conditions and for a stated period of time*”.

- **Quality**

Defined by (ISO 1994) as “*the totality of features and characteristics of a product or service that bear on its ability to satisfy stated or implied needs*”.

- **Availability**

“The ability of item to perform its required function at a stated instant of time or over a stated period of time” (BS 1979). The availability at time t is

$$A(t) = \Pr(\text{item is functioning at time } t) \quad (1.1)$$

The average availability A_{av} is

$$A_{av} = \frac{MTBF}{MTBF + MTTR} \quad (1.2)$$

Where: MTBF (Mean Time Between Failures) is the mean time that the item is functioning, and MTTR (Mean Time To Repair) is the mean downtime after a failure.

- **System safety**

The application of engineering and management principles, criteria, and techniques to achieve acceptable mishap risk, within the constraints of operational effectiveness and suitability, time, and cost, throughout all phases of the system life cycle (MIL-STD-882D 2000).

- **System safety engineering**

An engineering discipline that employs specialized professional knowledge and skills in applying scientific and engineering principles, criteria, and techniques to identify and eliminate hazards, in order to reduce the associated mishap risk (MIL-STD-882D 2000).

- **Risk acceptance criteria**

Risk acceptance criteria is defined by (Norway 2010) as ‘*criteria that are used to express a risk level that is considered as the upper limit for the activity in question to be tolerable*’.

- **Safety risk**

This aspect is defined by (Arendt & Lorenzo 2000) as ‘*a measure of human injury, environmental damage, or economic loss in terms of both the incident likelihood and the magnitude of the loss or injury*’.

- **Security risk**

Security risk is “*the likelihood that a defined threat exploit a specific vulnerability of a particular attractive target or combination of targets to cause a given set of consequences*” (American Institute of Chemical Engineers (Miner 2002)).

1.2 Risk analysis, Risk evaluation, Risk assessment, and Risk management

1.2.1 Risk analysis

Risk analysis can be defined as a systematic use of available information to identify hazards and to estimate the risk to individuals, property, and the environment (IEC 1995). This proactive approach consist mainly on three steps as shows Figure 1.1. In the first step, the hazards, the threats, and the potential hazardous events are identified. Then, the possible causes of each hazardous events are identified together with the probability (frequency) using experience data and/or expert judgments; this step is classified as a deductive analysis. Finally, the outcomes and their probability of occurrence, induced by a sequence of hazardous events are identified in the consequence analysis (inductive analysis) (Rausand 2011).

1.2.2 Risk evaluation

In this approach, analyst usually compare the results from the risk analysis and the risk acceptance criteria to define the most dangerous consequence (the one that exceed the risk acceptance criteria are considered the dangerous one). Risk evaluation is defined by (IEC 1995) as the ‘*Process in which judgments are made on the tolerability of the risk on the basis of a risk analysis and taking into account factors such as socioeconomic and environmental aspects*’.

1.2.3 Risk Assessment

The combination of the two aforementioned approach (i.e. risk analysis and risk evaluation) is the risk assessment. The latter is defined as ‘*Overall process of risk analysis and risk evaluation*’ (IEC 1995).

1.2.4 Risk management

A continuous management process with the objective to identify, analyze, and assess potential hazards in a system or related to an activity, and to identify and introduce risk control measures to eliminate or reduce potential harms to people, the environment, or other assets (Rausand 2011). Figure 1.1 summarize the three aforementioned approaches (risk analysis, risk evaluation, and risk management) and their main steps.

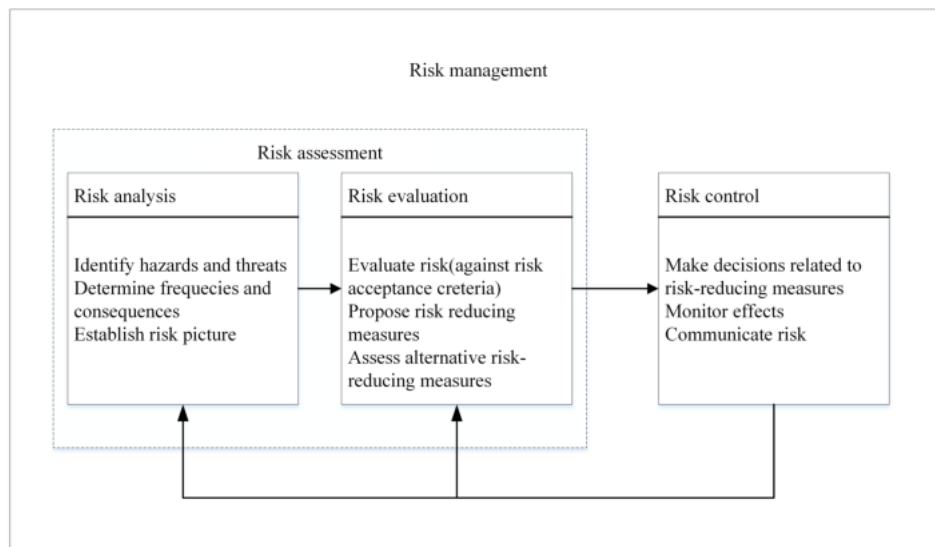

Figure 1.1: Risk analysis, evaluation, assessment, and management (Rausand 2011).

1.3 Development of Process Safety

The increasing demand on energy, food and chemical products (e.g. detergents and paints) caused by the social and technological development leads to the complexity of processing plants. This complexity rises the probability of new hazard that threat the neighborhoods of these plants. The hazard in such plants needs to be prevented and mitigated since it can cause catastrophic accidents. Researchers and industrial practitioners develop many methods for safety, risk and reliability analysis trying to avoid the appearance of accidents. Unfortunately, it seems that accidents still occur and the developed methods succeed only to decrease the number and severity of accidents but not to avoid it definitely. Faisal Khan and his collaborators (Khan et al. 2015) reviewed past process accidents that occurred during the last two decades using open-source database such as the United States Chemical Safety Board. The results from the database used are shown in Figure 1.2. It can be noted that the accident occurrences and their consequences show

a non-uniform fluctuation which can be explained by the uncertainty and unpredictable behaviour of accidents and their consequences (Khan et al. 2015). Obviously, a robust process safety and risk management is needed to better understand the mechanism of accidents and implement safety barriers to prevent and mitigate their severity. Process safety and risk management consist of different area such as hazard identification, risk assessment and management, accident modeling, and inherent safety. These entire aspects share common goal, which is reducing the risks to a tolerable level. To this end, researchers from different disciplines (particularly science and engineering) tried to develop methods to reach the process safety. Figure 1.3 shows the development in the disciplines relevant to the process safety; in our work we will focus more on Statistics and reliability engineering using Bayesian networks (yellow oval and yellow rectangle) and the intersection between statistics and reliability engineering and process equipment system and control.

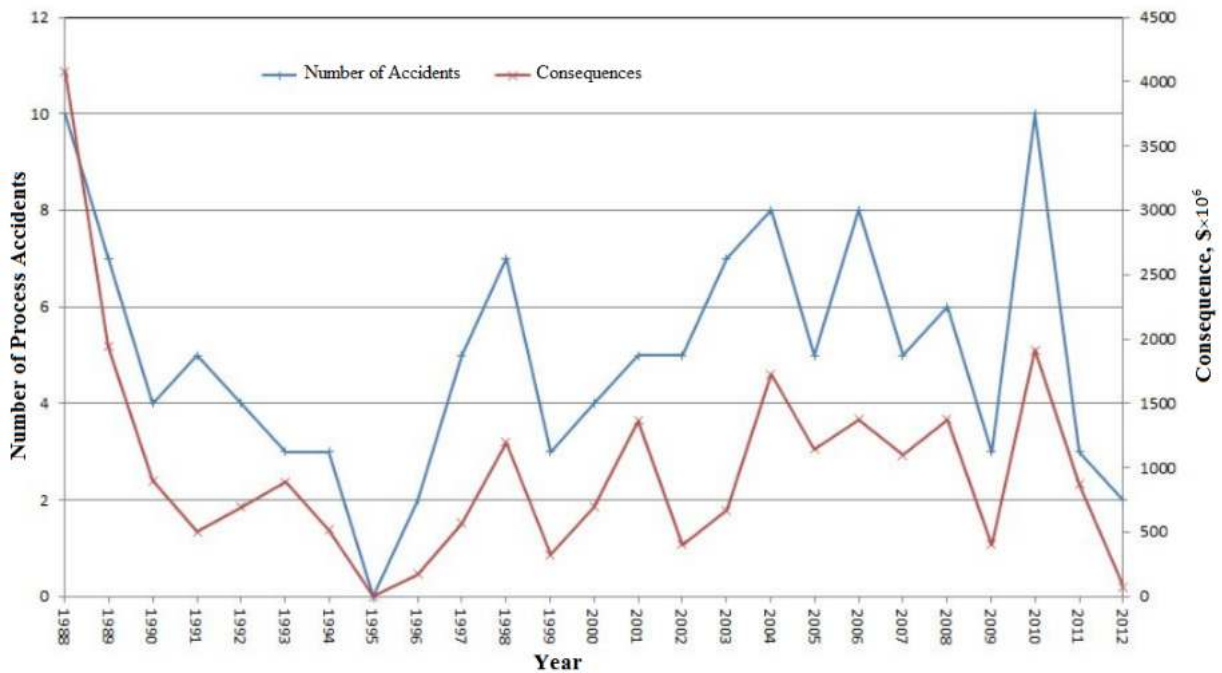

Figure 1.2: Accident trend analysis from 1988 to 2012 (Khan et al. 2015).

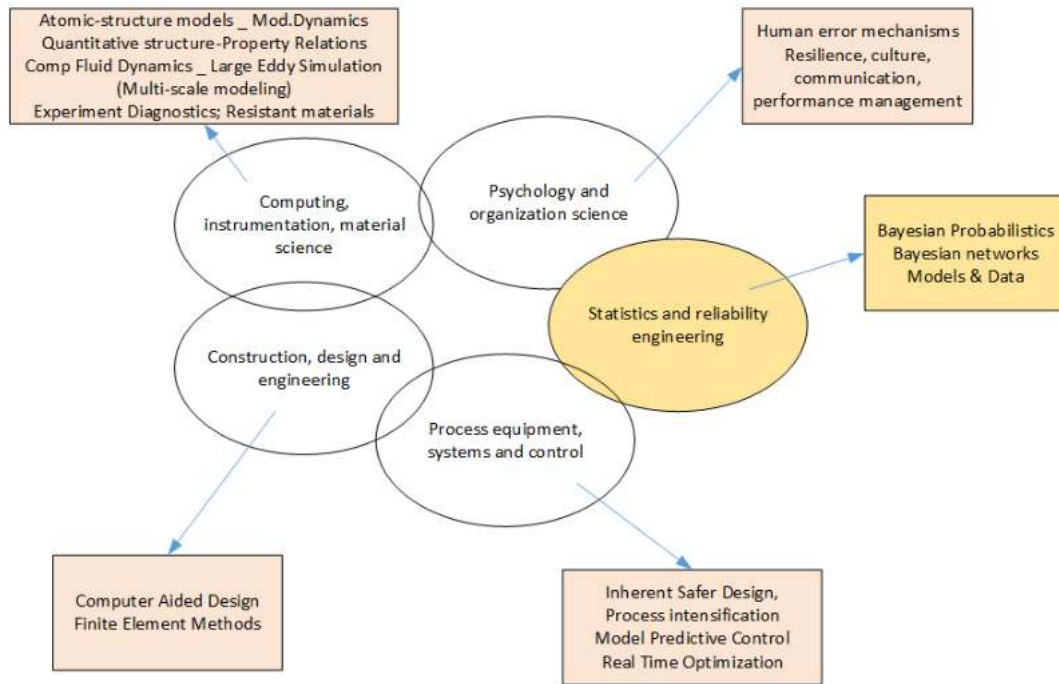

Figure 1.3: Developments in science and engineering relevant to process safety (De Rade-maeker et al. 2014).

1.4 Most catastrophic accidents in the last three decades

Event with the great effort to ensure the safety in the process industry by developing safety measure and enact legislations, accidents still occur. Table 1.2 reviews some of the most catastrophic accidents from 1980 until 2011. In the following, we have chosen few famous accidents that caused valuable losses in human life and economy in the last three decades and describe the cascading event lead to the accident.

Table 1.2: Overview of some of the major accidents in worldwide operations, 1980-2011 (updated from (Vinnem 2014)).

Year	Country	Installation	Type of accident	Number of fatalities
1982	Canada	Ocean Ranger	Capsize	84
1984	Brazil	Enchova	Ignited blowouts	42
1984	India	Union Carbide	Methyl Isocyanate leak from storage tank	3,787
1988	UK	Piper A	Explosion and fire	167
1989	UK	Ocean Odyssey	Ignited blowout	1
2001	Brazil	P-36	Explosion and fire	11
2002	Brazil	P-34	Serious listing	0
2004	Egypt	Temsah	Ignited blowout	0
2004	Algeria	GL1/K Complex	Explosion and fire	23
2005	India	Bombay north high	Ignited riser rupture caused by supply vessel collision	22
2007	Mexico	Usumacinta	Unignited blowout	22
2009	Australia	Montara/West Atlas	Unignited blowout	0
2009	Russia	Sayano–Shushenskaya power station	Turbine failure	75
2010	US	Macondo/ Deepwater Horizon	Ignited blowout	11
2010	Venezuela	Aban Pearl	Capsize	0
2011	Japan	Fukushima I Nuclear Power Plant	Tsunami that followed the Tohoku earthquake	0

1.4.1 The Ocean Ranger tragedy

Location: Newfoundland and Labrador, Canada.

Time: 15 February 1982.

Losses: 84 workers died.

Description of the accident:

The rig in Ocean Ranger designed and built by Offshore Drilling and Exploration

Company (ODECO) in 1976. It was a self-propelled, semi-submersible offshore drilling rig with the following characteristics: 121 meters long, 80 meters wide, and 103 meters tall. It was a large rig that is need around 80- 100 workers to control and for the drilling operations. The signs of the accident start when the crew of the rig received a weather report stating that a strong winter storm is coming to their location a day before the accident (Sunday 24 February 1982). The Ranger stopped the drilling operations for the safety of the crew and the installations and prepared for the storm to pass. Later, nearby support vessels start to overheard radio chatter that some problems appeared including broken glass and failures in switches and valves (operating by themselves). Two hours after, The Ranger confirmed in the radio that everything is fine and there are no serious problems. Nevertheless, on Monday morning (1:00 am), the Ranger contacted the supply vessel to move in closer to the rig. A half hour later, the crew start to head to lifeboat stations, this was the last message received from the Ranger crew. Two rigs was nearby from the Ranger, they send their standby vessels, the supply vessel “Seaforth Highlander” also headed towards the rig. The storm’s violence makes it very difficult to make headway or searching for survivors. What a tragedy, not a single man survived. Days after the accident, 22 bodies were recovered from the water; they all died of drowning and hypothermia. Almost a month later, the investigation about the causes of the disaster began. The Royal Commission, which is the responsible of this investigation, found that several causes contributing the accident including; design flaws in the rig, inadequate lifesaving equipment, and the most important lacked training of the crew in the case of an emergency (Collier 2010).

1.4.2 The Bhopal disaster

Location: Bhopal, Madhya Pradesh, India.

Time: 2– 3 December 1984.

Losses: Deaths, at least 3,787; over 16,000 claimed.

Description of the accident:

The Bhopal gas tragedy is one of the most catastrophic accident in the world’s history. The tragedy happened on December 3, 1984, where a toxic methyl isocyanate (MIC) was released from a storage tank affiliated to the Union Carbide India Limited (UCIL) pesticide plant in Bhopal. The gas released to the atmosphere cover 40 km² of area and killed or affected thousands of people. Even today, people of Bhopal are still suffering the aftermath of the accident. Lately, the Indian government state that around 200 000

citizens in Bhopal was affected and still suffering from serious ill health issues. The main cause of this disaster was a “jumper line” connecting a relief valve header to a pressure vent header, enabling water to enter MIC storage Tank 610 (Yang et al. 2015). Labib and Champaneri (Labib & Champaneri 2012) prepared a good report about the accident and the causes behind it.

1.4.3 Sayano–Shushenskaya power station accident

Location: Yenisei River, near Sayanogorsk in Khakassia, Russia.

Time: 17 August 2009 at 08:13 (00:13 GMT)

Losses: 75 people were killed and billions of roubles have losses.

Description of the accident:

A report from Federal Environmental, Technological and Atomic Supervisory Service on 4 October 2009 states that the origin of the accident starts by a turbine vibration that caused a fatigue damage of the mountings of the turbine 2 and its cover. The latter missed at least six nuts from the bolts securing the turbine cover. After that, 49 bolts from the turbine are investigated; it is found that 41 had fatigue cracks and 8 bolts (from 41) their fatigue area exceeded 90% of the total cross-sectional area. At 1:20 AM, a fire was noticed at the hydroelectric power station of Bratsk, the fire broke the communications and the automatic driving systems in the station. At 8:12 AM, the turbine regulator reduces the output power of turbine 2. After that, the bolts keeping the turbine cover in place broke, and under water pressure of about 20 bars, the spinning turbine with its cover, rotor, and upper parts started to move up and caused the destruction of machinery hall installations. At the same time, pressurized water flooded the rooms and damaged plant constructions. The failure of turbine 2 caused the failure of the automatic shutdown system of the water intake pipes' gates, more detail can be found in (Wikipedia contributors 2017a).

1.4.4 Fukushima Daiichi nuclear disaster

Location: Okuma, Fukushima, Japan.

Time: 11 March 2011

Losses: Non-fatal, 37 injuries, propagation of radiation.

Description of the accident:

The International Nuclear Event Scale classifies the accident as level 7 event (Major accident), even there is no fatalities but it is expected the death of hundreds of people due

to the radiation caused by the accident. The main cause of the accident was reported to be the tsunami that followed the Tohoku earthquake on 11 March 2011. Thereafter, the active reactors shut down their sustained fission reactions automatically. The tsunami disabled the emergency generators that feed power to the pumps responsible for the cool of the reactors. These latter suffer from increasing temperature, and caused three nuclear meltdowns, hydrogen-air chemical explosions, and the release of radioactive material in three units. In addition, loss of cooling in the reactors lead to the overheat of the pool that store spent fuel from reactor 4. After an investigation from the Fukushima Nuclear Accident Independent Investigation Commission (NAIIC) On 5 July 2012, it is found that Tokyo Electric Power Company (TEPCO), which is the plant operator, had failed to implement the required safety requirements such as risk assessment and developing evacuation plans, for more detail see (Wikipedia contributors 2017b).

1.4.5 Deep-water Horizon (the Macondo blowout)

Location: Gulf of Mexico, US.

Time: 20 April 2010

Losses: 11 workers died, 17 injured and millions of gallons of oil spilled in the Gulf.

Description of the accident:

Deep-water Horizon began the drilling operation on the Macondo well in February 2010, in the southeast coast of Louisiana, US. The water depth at the site was around 1500 m, and the well was 5500 m below sea level (Skogdalen & Vinnem 2012). An investigation by BP in September 2010 (Arias et al. 2010) states that the accident starts with the failure of well integrity following by a loss of control of the pressure of the fluid in the well. Also, the failure of the blowout preventer which role is to seal the well in case of loss of control. Hydrocarbons shot up the well at an uncontrollable rate and ignited which lead to fire and explosions on the rig. The human hand has also their share in the accident. In the BP report about the accident, they blamed the rig owners ‘Transocean’ for their failure to maintain the BOP. Nevertheless, in the final report of Deepwater Horizon, they stated: ”This disaster was preventable if existing progressive guidelines and practices been followed”, but BP ”did not possess a functional safety culture”. Functional safety means to take into account the whole property of the system rather than just one component property. They also said, ”as a result of a cascade of deeply flawed failure and signal analysis, decision-making, communication, and organizational - managerial processes, safety was compromised to the point that the

blowout occurred with catastrophic effects.”

1.5 Accident process model

These models are usually used for incident investigation and prevention. Figure 1.4 depicts the Huston model that discuss the factors that contribute to the incidents and some steps that can be taken to avoid them. The model shows that three major factors (input) are necessary to cause accident: target, driving force, and trigger. The model also represents some action to reduce the severity of the incident. The contact probability may be minimized by preventive action. The contact efficiency and contact effectiveness may be reduced by adaptive reaction (Sam Mannan 2005). However, due to the complexity of nowadays plants, this model cannot give an outstanding picture about the accident. Many models for the accident process can be found in the literature such as:

- Fault tree model (Figure 1.5) developed by (Johnson 1980);
- Rasmussen model (Rasmussen 1982)(Rasmussen & Lind 1982) that incorporate human factors;
- Kletz model (Kletz 1991) which shows the sequence of decisions and actions that lead to the accident and shows the recommendations arising from the investigation for each step;
- Industrial risk analysis model based on the systemic approach referred to as Analysis Method of Dysfunctional Systems (MADS). As one can see in figure 1.6, the model is composed of two main systems, target system and danger source. In the latter, many sub-systems (SS) connected can be found, more detail regarding MADS model is presented in (Bouloiz et al. 2010).

Recently, many models for accident process have been proposed, most based on the aforementioned models but adding some elements to make the model more flexible. As an example, Adedigba et al. (Adedigba et al. 2016) propose a new model that incorporate external factors such as an earthquake, storm or lightning as potential sources of hazards for process plants. The dependent relationships between different elements in the model such as design error, operational failure and equipment failure is shown in Figure 1.7.

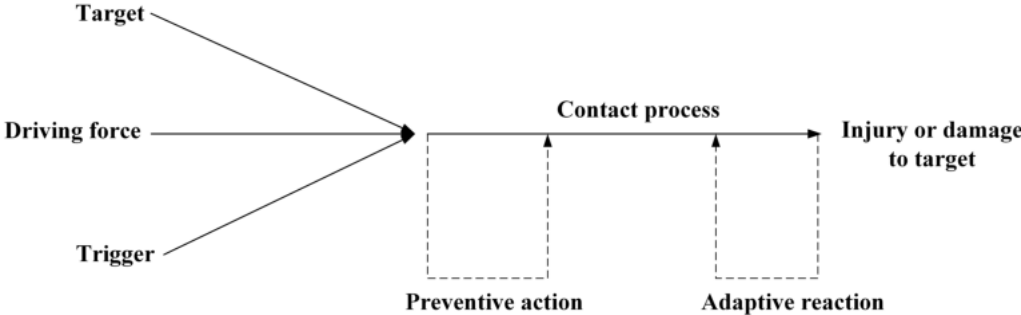

Figure 1.4: Houston model of the accident process (Houston 1971).

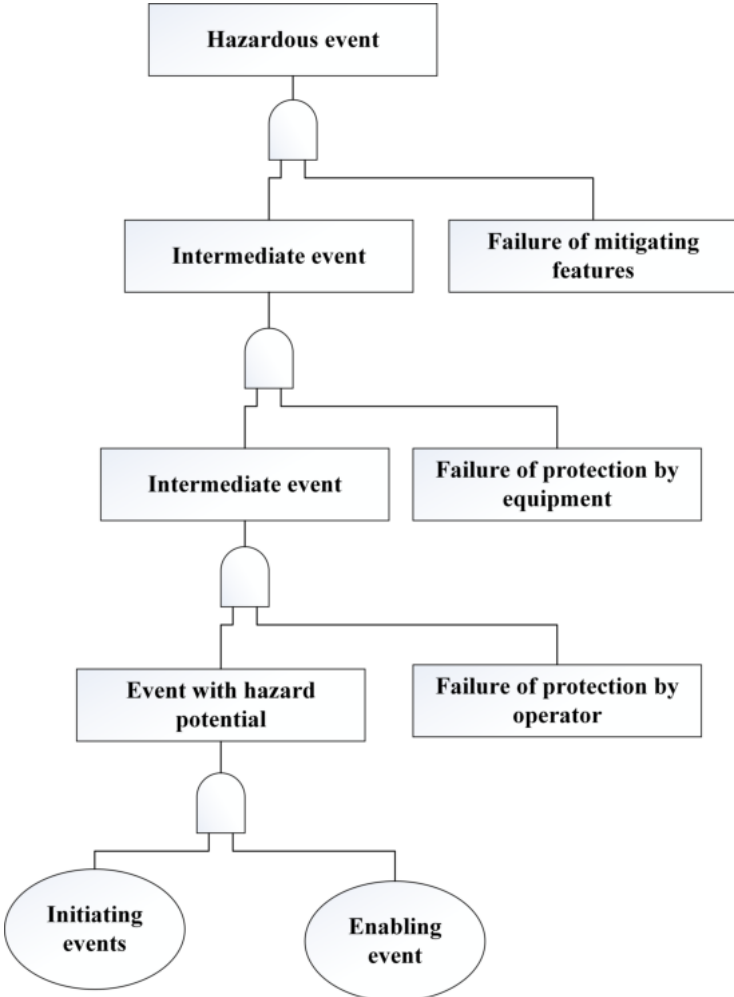

Figure 1.5: Fault tree accident model (Khan & Abbasi 1999).

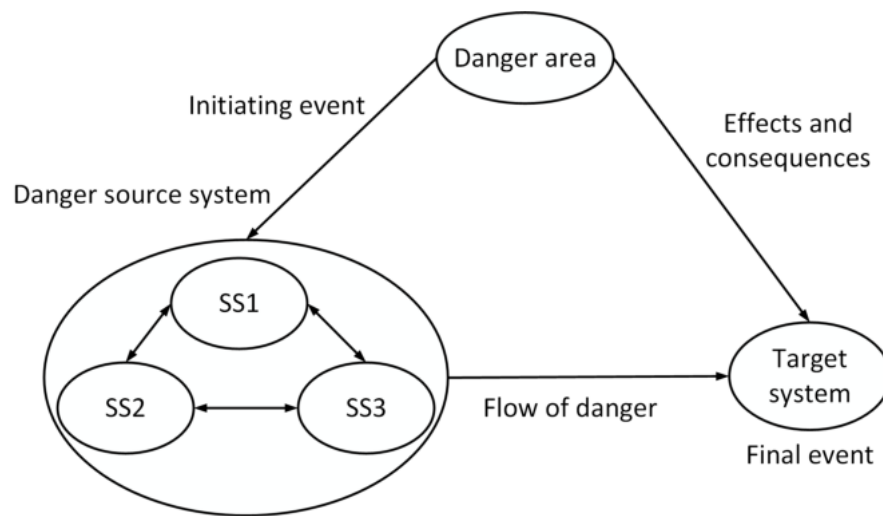

Figure 1.6: MADS model (Bouloiz et al. 2010).

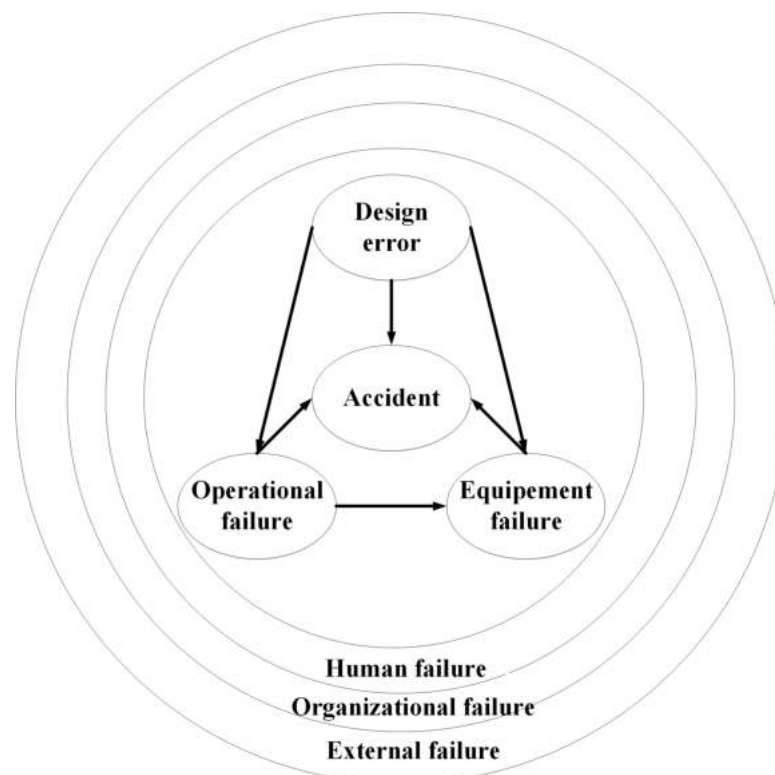

Figure 1.7: Accident model that incorporate human, organizational, and external failure (Adedigba et al. 2016).

1.6 Safety and risk analysis techniques

Different approaches have been developed for safety and risk analysis, a review of such techniques can be found in (Khan & Abbasi 1998). All of these techniques share one objective, which is to identify qualitatively or quantitatively the possible causes and consequences from hazard or threat in the process. We will briefly discuss some techniques and methodologies that is used extensively for risk assessment of process industries. As mentioned before, these techniques are divided into qualitative and quantitative methods.

1.6.1 Qualitative approaches

These techniques depend mostly on the hazard identification using qualitative data resources. It is obviously noted that a quantitative risk analysis (QRA) need both qualitative and quantitative data to give a comprehensive picture of the risk but if no data are available to make inferences from, then a QRA would not be possible (Coleman and Marks 1999). Many techniques are developed in the literature such as HAZOP, FMEA; What-if analysis and Hazard indices; in this section, we will discuss the most used methods based on the review presented by (Khan and Abbasi 1998):

HAZOP (Hazard and Operability)

HAZOP is one of the most used technique since the seventies, it was standardized in 2001 by international standard IEC 61882 (IEC 61882 2001), to provide a guidance on application of the technique and on the study procedure. It began when a deviation from normal conditions occur. Users and experts depend on design and operation documents such as PI&Ds and PFD to construct HAZOP table. It should be know that this method can only be built by a group of multi-disciplinary expert who have enough information about design, operation and maintenance of the process plant. Table 1.3 shows some of deviations that can occur from a process plant. Some of the outstanding features of HAZOP are that it can be performed in both the design stage and the operational stage; also, it gives information about the potential hazards of specified deviation as well as their causes, and consequences. Nevertheless, this method is time consuming and can only be conducted by a group of experts.

Table 1.3: Guide words and their physical significance (derives from (Khan and Abbasi 1998))

Guide word	Meaning	Parameter	Deviation
None	Negation intention	Flow Level	No flow Zero level
Less	Quantitative decrease	Flow Level Temperature Pressure Concentration	Low flow rate Low level Low temperature Low pressure Low concentration
More	Quantitative increase	Flow Level Temperature Pressure Concentration	High flow rate High level High temperature High pressure High concentration
Reverse	Logical opposite	Flow Pressure	Reverse flow rate Reverse pressure

FMEA (Failure Mode Effect Analysis)

FMEA is an inductive method used to identify and eliminate known and/or potential failures, problems, errors from the system, design, process, and/or service. In addition, it provides the designer with the required information about the causes and effects of failures before the system, design, process, or service is finalized. Also, it identifies corrective actions required to prevent failures from reaching the customer. Usually, FMEA examine the individual components such as vessels, pumps and valves that could lead to system failure. One of the most advantage in this method that can be started as soon as some information is known. It does not need all information to be known. It depend of the motto ‘Do the best you can, with what you have’because this is what we deal in the real life tasks (Stamatis, D.H 2003). Some of the information required to stat FMEA includes; system structure, system operation, control and maintenance, system environment and system modeling. An exhaustive guidance is provided from International Standard IEC 60812 (IEC 60812 2006); the latter clarifies the procedural steps necessary to perform an analysis, defines different terms, assumptions, criticality measures, failure modes, and

gives the basic principles with an examples of the necessary worksheets and tabular forms. An extension of this method referred to as Failure mode, effects, and criticality analysis (FMECA) subject to the same considerations presented for FMEA.

What-if analysis

This analysis consists of asking series of questions that begin with” what if” aims to identify a hazard in the system, even though, it is not necessary used ‘what if’, also other phrases can be used. Examples of such questions are:

- What if the valve does not open?
- What if inert gas is omitted?

This method performed without need of specialized technique of computational and the questions established used in the entire life of the project. Some of its limits are that the usefulness of this method is measured by the right questions asked and it is more subjective compared with the other methods (HAZOP and FMEA), also only a team of experts can perform what-if analysis.

SWIFT (structured what-if technique)

The structured what-if technique (SWIFT) is an extension of the abovementioned technique, SWIFT is a systems-based risk identification technique that often required the use of guide words such as timing, amount and prompts (phrases) elicited from participants (phrases begin with “What if. . .” or “How could. . .”) to check risks at systems and investing how the latter will be affected by deviations from normal operations (Card et al., 2012). SWIFT is a flexible technique that can be conducted more quickly and required lower level of detail compared with HAZOP and FMEA methods. A detailed description of SWIFT method is presented in (Card et al. 2012).

1.6.2 Quantitative approaches

Quantitative techniques consist of identifying the risk or hazard numerically. Probability or likelihood is assigned to each hazard that may occur in the process plant which help to quantify the possible outcomes and make the right decisions when there is uncertainty. Some of these methods are discussed in the following;

Fault Tree Analysis (FTA)

FTA is a deductive method aimed to identify an undesired event (e.g. accident or failure of system), then constructed downwards the tree until reach the root cause of the undesired event. This latter referred to as the Top Event (TE) and the root cause known as the primary event or the basic event. FTA can be applied for wide range of applications such as safety analysis, availability, and maintainability analysis. The international standard IEC 61025 (IEC 61025 2006) addresses two sorts of approaches to FTA, a qualitative approach where the potential causes of the TE are sought out with no interest in their likelihood of occurrence. A probability of occurrence is assigned for each basic event in the quantitative approach, the result of this approach is the probability of occurrence of a TE. This technique is well discussed in chapter 3.

Event tree (ET) technique

The International Standard IEC 62502 (IEC 62502 2010) specifies the basic principles of Event Tree Analysis (ETA) and represents a map for the use of ETA qualitatively and quantitatively in the context of dependability and risk analysis. Opposite to FTA, ETA is an inductive method that is often used for risk assessment and accident scenario modeling. ET utilizes decision trees to graphically model the possible outcomes (consequences) of an initiating event (IE) (e.g. malfunctioning in the system or process) capable of producing an accidental result by a sequence of events as shown in Figure 1.8, the latter represent an example of Liquefied petroleum gas (LPG) release at a detergent alkylate plant (DAP). The initiating event of ET uses dichotomous conditions (i.e., success/failure, true/false or yes/no) to identify sequenced events, safety barriers and consequences in different branches of the tree (Ferdous et al. 2009). The occurrence probability of a specific outcome event (P_{OE}) can be obtained by multiplying the probabilities of all subsequent events $P_i = (P_1, P_2, \dots, P_n)$ existing in a path (Hong et al. 2009) as shown in equation 1.3. An example of calculation is given in the following;

$$P_{OE} = \prod_{i=1}^n P_i \quad (1.3)$$

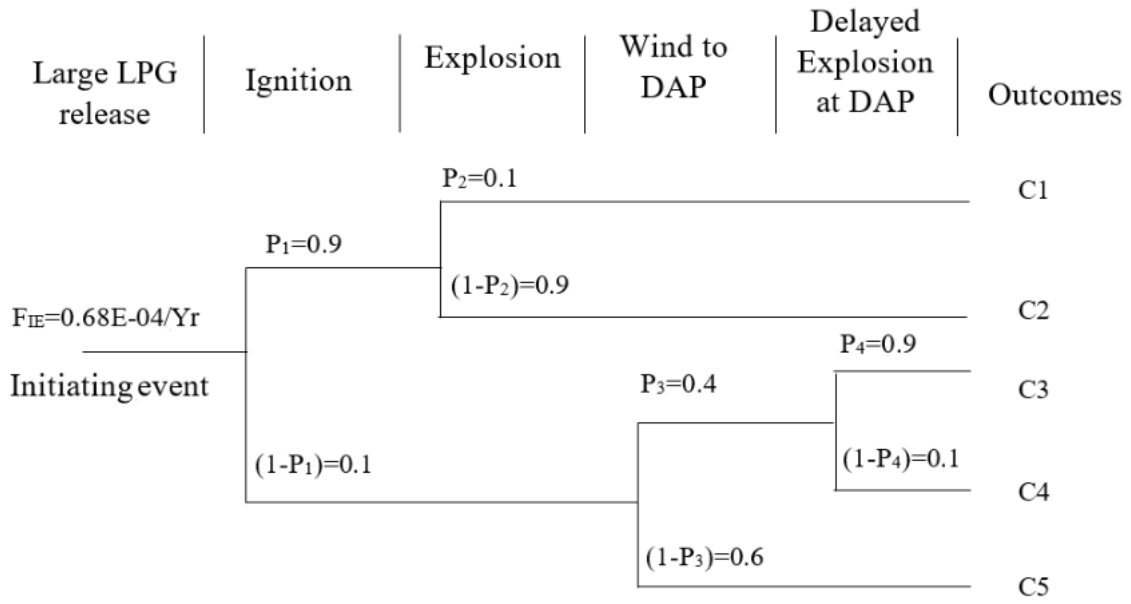

Figure 1.8: Event tree for LPG release (Ferdous et al. 2009).

Calculus of the first outcome (consequence 1):

$$F(C_1) = F_{IE} \times P_1 \times P_2 = 0.68 \times 10^{-4} \times 0.9 \times 0.1 = 6.12 \times 10^{-6}/Yr \quad (1.4)$$

Bow-Tie Analysis (BT)

The combination of the two aforementioned techniques FT and ET known as Bow-tie analysis (BT); for more detail of this method see chapter 4.

Bayesian networks (BNs)

BN is a directed acyclic graph (DAG) that consists of a set of variables and a set of directed arcs. A BN is a causal network with a quantitative representation of the causal links. In BN, the variables is represented by nodes, each node is specified by a conditional probability table (CPT) if it is a child node or an unconditional probability table for a parent node (Vileiniskis et al. 2016). These tables are usually built using expert knowledge. The construction of BN model consists of the following (Nielsen & Jensen 2009):

- A set of variables and a set of directed edges between variables;
- Each variable has a finite set of mutually exclusive states;

- The variables together with the directed edges form a DAG. A directed graph is acyclic if there is no directed path $A_1 \rightarrow \dots \rightarrow A_n$ so that $A_1 = A_n$;
- To each variable with parents, a conditional probability table (CPT) is attached.

An example of Bayesian networks

To better understand the way of reasoning in Bayesian network, we will use the example of “Car Start Problem” that is proposed by (Jensen & Nielsen 2007): “In the morning, my car will not start. I can hear the starter turn, but nothing happens. There may be several reasons for my problem. I can hear the starter roll, so there must be power from the battery. Therefore, the most probable causes are that the fuel has been stolen overnight or that the spark plugs are dirty. It may also be due to dirt in the carburetor, a loose connection in the ignition system, or something more serious. To find out, I first look at the fuel meter. It shows half full, so I decide to clean the spark plugs.”

First, we have to construct a graph that explain the situation and represent the causal relations between chosen events. Using the paragraph above, we choose four main variables: Fuel, Clean Spark Plugs, Fuel Meter standing, and Start. For each variables, we assign different states such as {yes, no} for fuel, clean spark plugs, and start, also {full, $\frac{1}{2}$, empty} for fuel meter event. Thereafter, we construct a model for the situation depending on our perspective, for example, both fuel and clean spark plugs have a causal impact on the start of the car. In addition, fuel has an impact on the Fuel Meter Standing state. BN in Figure 1.9 summarize the relationship between events. Fu, SP, St, and FM are the abbreviations of fuel, clean spark plugs, start, and fuel meter standing, respectively.

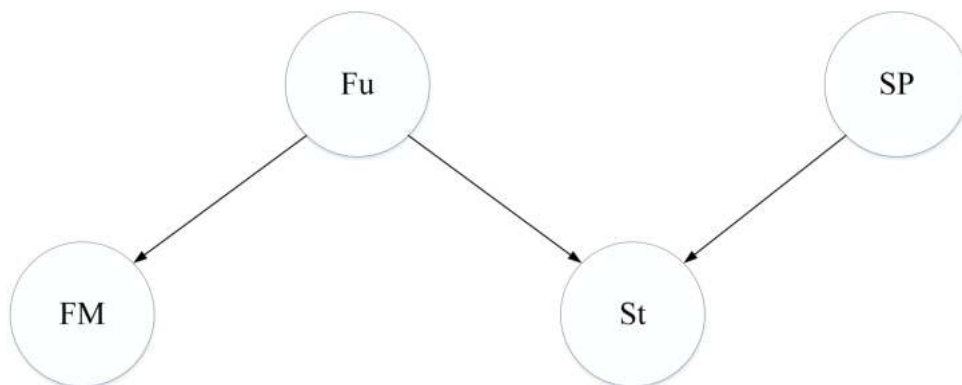

Figure 1.9: Bayesian network for the reduced car start problem

The first part of BN (Figure 1.9) referred to as the qualitative part. The big advantage of BN that we can perform quantitative modeling by assigning a probability assessment

for each variables in the graph. The following tables represent the probability of each variable, the first ones called unconditional tables (parents nodes) as shows Table 1.4, and the others are conditional tables (child nodes) as depicted in Table 1.5

Table 1.4: Unconditional probabilities for the parent nodes.

Fu	Yes	0.98
	No	0.02
P(Fu)		
SP	Yes	0.96
	No	0.04
P(SP)		

Table 1.5: Conditional probabilities for the child nodes.

		Fu	Yes	No		
FM	Full		0.39	0.001		
	$\frac{1}{2}$		0.6	0.001		
	Empty		0.01	0.998		
		P(FM \ Fu)				
		Fu	Yes		No	
		SP	Yes	No	Yes	No
St	Yes	0.99	0.01	0	0	
	No	0.01	0.99	1	1	
		P(St \ Fu, SP)				

The chain rule in Bayesian networks

Theorem Let BN be a Bayesian network over $U = \{A_1, A_2, \dots, A_n\}$. Then BN specifies a unique joint probability distribution $P(U)$ given by the product of all conditional probability tables specified in BN:

$$P(U) = \prod_{i=1}^n pa(A_i) \tag{1.5}$$

Where $pa(A_i)$ is the parents of A_i in BN, and $P(U)$ reflects the properties of BN. For the proof of the aforementioned equation see (Jensen & Nielsen 2007).

Based on the equation above, the joint probability is calculated for the reasoning in Bayesian network of the Car Start Problem:

$$P(Fu, FM, SP, St) = P(Fu)P(SP)P(FM \setminus Fu)P(St \setminus Fu, SP) \quad (1.6)$$

The no start of the car is the situation handled in the example, so the evidence is $St = no$. So, what is the cause or better the variable with the high contribution on the no start of the car, is it the need to the fuel? Or the dirty of the spark plug? Table 1.6 is used to answer these two questions.

Table 1.6: The joint probability table for P (Fu, FM, SP, St = no).

FM		Full		$\frac{1}{2}$		Empty	
Fu		Yes	No	Yes	No	Yes	No
SP	Yes	0.00367	0.000019	0.00564	0.000019	0.000094	0.0192
	No	0.01514	0.0000008	0.0233	0.0000008	0.000388	0.000798

By summing each row in Table 1.6, we get $P(SP, St = no) = (0.02864, 0.03965)$ and by dividing this equation by $P(St = no)$, we get the conditional probability $P((SP \setminus St = no))$. Knowing that $P(St = no) = P(SP = yes, St = no) + P(SP = no, St = no) = 0.02864 + 0.03965 = 0.06829$. Finally, we get $P(SP \setminus St = no) = (0.42, 0.58)$.

Using the same way as above, we find that $P(Fu \setminus St = no) = (0.71, 0.29)$. We can conclude from the two previous results that dirty of the spark plugs is the closest variable that lead to no start of the car. Now, assuming that we check the fuel meter and we get an information that the fuel meter's index indicates half ($FM = \frac{1}{2}$), the numbers of the situation are given in Table 1.7.

Table 1.7: The joint probability table for P (Fu, SP, St = no, FM = $\frac{1}{2}$)

FM		$\frac{1}{2}$	
Fu		Yes	No
Sp	Yes	0.00564	0.000019
	No	0.0233	0.0000008

Calculating the conditional probability, we get $P(Fu \setminus St = no, FM = \frac{1}{2}) = (0.999, 0.001)$ and $P(SP \setminus St = no, FM = \frac{1}{2}) = (0.196, 0.804)$. We can conclude that the probability of $SP = yes$ increased when we observed that $FM = \frac{1}{2}$ (for more detail about BN see chapter 2 and 3).

Advantages of BN

Unlike the aforementioned methods, BN offer an advanced dependencies modeling, dynamic analysis, and more flexible structures. In the dependencies modeling, two ways can be distinguished, a vertical dependency where the relation between the basic nodes, the intermediate nodes, and the leaf node are presented. The other way is the horizontal dependency where the basic nodes are depending on each other. The latter way makes BN more effective from FT and ET, since these methods suppose the basic event independence. The dependencies are all presented in form of conditional probabilities table (CPT) where available data from references and expert knowledge are used to fill these CPTs (Deyab, Taleb-berrouane, Khan, & Yang, 2018). BN can update event probabilities using the Bayesian updating mechanism by incorporating new information from system, a feature that FT and ET are incapable to incorporate, this is what make BN a suitable tool for dynamic analysis (Khan et al., 2016). A comparison of FT and BN in dependability analysis and safety analysis is presented in (Bobbio, Portinale, Minichino, & Ciancamerla, 2001) (Khakzad, Khan, & Amyotte, 2011). These comparisons show the advantages of BN over FT in representing the dependencies of events, updating probabilities, and coping with uncertainties. In addition, BN can incorporate multi-state variables, dependent failures, functional uncertainty, common cause failures, and expert opinion in different domains. Since FT, ET, and BT can be mapped into BN, so the abovementioned features of BN are the same for the three methods.

Disdvantages of BN

Even with the great capabilities of BN in different modeling, BN have some problems regarding modeling of temporal dependencies, also there is no guide about how to form the appropriate reliability or dependability model (Ondřej Nývlt, 2015), this is why usually FT used to build reliability or dependability model then the latter is converted to BN. Moreover, BN require a high computational burden to construct conditional probability tables, which make it very difficult to model complex dependencies among variables (Khan et al., 2016).

1.7 Conclusion

In the current chapter, we tried to give a short review about the concepts related to safety and risk analysis. Several accidents from literature have been addressed, most of them happened in the last decade. In addition, different accident process models are presented and some techniques for safety and risk analysis have been discussed. Further-

more, the Bayesian networks method is well presented together with its advantages and disadvantages.

It is obviously important to establish a risk assessment in the nowadays industries to avoid catastrophic accident that causes heavy losses (i.e. human losses and environmental pollution). In the literature, we can find a quite number of approaches proposed for risk and safety analysis. Nevertheless, accidents still occur, human losses their life, and millions of dollars go in vain. It is important to test the effectiveness of these methods by comparing them with other ones. In the next chapter, we will review the applications of BN in the process industry and chemical plants in the last decade, and give a simple application of BN in the oil and gas sector.

References

Adedigba SA, Khan F, Yang M, et al (2016) Process accident model considering dependency among contributory factors. *Process Saf Environ Prot* 102:633–647. doi: 10.1016/j.psep.2016.05.004

Antonioni G, Spadoni G, Cozzani V (2009) Application of domino effect quantitative risk assessment to an extended industrial area. *J Loss Prev Process Ind* 22:614–624. doi: 10.1016/j.jlp.2009.02.012

Arendt JS, Lorenzo DK (2000) *Evaluating Process Safety in the Chemical Industry*. New York, USA: Center for Chemical Process Safety. Am Inst Chem Eng

Arias JT, Higuaita JC, Castrillón OD (2010) Deep Water The Gulf oil disaster and the future of offshore drilling

Bobbio A, Portinale L, Minichino M, Ciancamerla E (2001) Improving the analysis of dependable systems by mapping Fault Trees into Bayesian Networks. *Reliab Eng Syst Saf* 71:249–260. doi: 10.1016/S0951-8320(00)00077-6

Bouloiz H, Garbolino E, Tkiouat M (2010) Contribution of a systemic modeling approach applied to support risk analysis of a storage unit of chemical products in Morocco. *J Loss Prev Process Ind*. doi: 10.1016/j.jlp.2009.12.001

British Standards Institution (2007) *Occupational health and safety management systems - Requirements*

BS (1979) 4778, *Glossary of Terms Used in Quality Assurance (Including Reliability and Maintainability Terms)*. Br Stand Institution, London

Card AJ, Ward JR, Clarkson PJ (2012) Beyond FMEA: the structured what-if tech-

nique (SWIFT). *J. Healthc. Risk Manag.*

Coleman ME, Marks HM (1999) Qualitative and quantitative risk assessment. *Food Control* 10:289–297. doi: 10.1016/S0956-7135(99)00052-3

Collier K (2010) The Loss of the Ocean Ranger, 15 February 1982. In: *Newfoundl. Labrador Herit.* url<http://www.heritage.nf.ca/articles/economy/ocean-ranger.php>. Accessed 31 Jul 2017

De Rademaeker E, Suter G, Pasman HJ, Fabiano B (2014) A review of the past, present and future of the European loss prevention and safety promotion in the process industries. *Process Saf Environ Prot* 92:280–291. doi: 10.1016/j.psep.2014.03.007

Deyab SM, Taleb-berrouane M, Khan F, Yang M (2018) Failure analysis of the offshore process component considering causation dependence. *Process Saf Environ Prot.* doi: 10.1016/j.psep.2017.10.010

Ferdous R, Khan F, Sadiq R, et al (2009) Handling data uncertainties in event tree analysis. *Process Saf Environ Prot* 87:283–292. doi: 10.1016/j.psep.2009.07.003

Hong E-S, Lee I-M, Shin H-S, et al (2009) Quantitative risk evaluation based on event tree analysis technique: Application to the design of shield TBM. *Tunn Undergr Sp Technol* 24:269–277. doi: 10.1016/j.tust.2008.09.004

Houston DEL (1971) New approaches to the safety problem. *Major Loss Prev Process Ind* 210

IEC 60300-3-9 (1995) Dependability Management–Part 3: Application Guide–Section 9: Risk Analysis of Technological Systems

IEC 60812 (2006) Analysis techniques for system reliability – Procedure for failure mode and effects analysis (FMEA).[IEC 60812]. *Int Electrotech Comm*

IEC 61025 (2006) Fault tree analysis. [IEC 61025]. *Int Electrotech Comm*

IEC 61882 (2001) Hazard and operability studies (HAZOP studies)-application guide. [IEC 61882]. *Int Electrotech Comm*

IEC 62502 (2010) Analysis techniques for dependability – Event tree analysis (ETA). [IEC 62502]. *Int Electrotech Comm*

Isermann R (2006) Fault-diagnosis systems: An introduction from fault detection to fault tolerance

ISO NZS (1994) Australian / New Zealand Standard Quality management and quality assurance — Vocabulary

Jensen F V., Nielsen TD (2007) *Bayesian Networks and Decision Graphs*

Johnson WG (1980) *MORT safety assurance systems.* Marcel Dekker Inc

Khakzad N, Khan F, Amyotte P (2011) Safety analysis in process facilities: Comparison of fault tree and Bayesian network approaches. *Reliab Eng Syst Saf* 96:925–932. doi: 10.1016/j.ress.2011.03.012

Khan F, Hashemi SJ, Paltrinieri N, et al (2016) Dynamic risk management: a contemporary approach to process safety management. *Curr. Opin. Chem. Eng.*

Khan F, Rathnayaka S, Ahmed S (2015) Methods and models in process safety and risk management: Past, present and future. *Process Saf Environ Prot* 98:116–147. doi: 10.1016/j.psep.2015.07.005

Khan FI, Abbasi S. (1998) Techniques and methodologies for risk analysis in chemical process industries. *J Loss Prev Process Ind* 11:261–277. doi: 10.1016/S0950-4230(97)00051-X

Khan FI, Abbasi S. (1999) Reply to comments on “Major accidents in process industries and an analysis of causes and consequences.” *J Loss Prev Process Ind* 14:85. doi: 10.1016/S0950-4230(00)00016-4

Kletz T (1991) Piper alpha: latest chapter in a long story. *J Loss Prev Process Ind* 4:277–278

Labib A, Champaneri R (2012) The Bhopal Disaster-learning from failures and evaluating risk. *Maint Eng* 27:41–47

Mannan S (2005) *Lees’ loss prevention in the process industries*. Butterworth-Heinemann

MIL-STD-882D (2000) Department of Defense 2000 “MIL-STD-882D System Safety Program Requirements. *Stand Pract Syst Safety*” Washingt DC USA

Miner G (2002) Guidelines for Analyzing and Managing the Security Vulnerabilities of Fixed Chemical Sites. *Am Water Work Assoc J* 94:126

Nielsen TD, Jensen FV (2009) *Bayesian Network and Decision Graph*. Springer Science & Business Media

Norway S (2010) Risk and emergency preparedness analysis. *NOROSK Stand Z-013, Rev 3*:16–18

Ondřej Nývlt (2015) *Risk Management Methods for Industrial Systems*. Czech Technical University in Prague

Perrin L, Muñoz-Giraldo F, Dufaud O, Laurent A (2012) Normative barriers improvement through the MADS/MOSAR methodology. *Saf Sci*. doi: 10.1016/j.ssci.2012.02.002

Rasmussen J (1982) Human errors. A taxonomy for describing human malfunction in industrial installations. *J Occup Accid* 4:311–333. doi: 10.1016/0376-6349(82)90041-4

Rasmussen J, Lind M (1982) A Model of Human Decision Making in Complex Systems and its Use for Design of System Control Strategies. 1982 Am. Control Conf. 270–276

Rausand M (2011) Risk Assessment: Theory, Methods, and Applications. John Wiley & Sons

Reniers GLL (2010) Multi-plant Safety and Security Management in the Chemical and Process Industries. WILEY-VCH Verlag GmbH & Co. KGaA, Weinheim

Skogdalen JE, Vinnem JE (2012) Quantitative risk analysis of oil and gas drilling, using Deepwater Horizon as case study. Reliab Eng Syst Saf 100:58–66. doi: 10.1016/j.ress.2011.12.002

Stamatis, D.H (2003) Failure Mode and Effect Analysis: FMEA from Theory to Execution

Vileiniskis M, Remenyte-Prescott R, Rama D, Andrews J (2016) Fault detection and diagnostics of a three-phase separator. J Loss Prev

Process Ind 41:215–230. doi: 10.1016/j.jlp.2016.03.021 Vinnem JE (2014) Offshore Risk Assessment vol 2 Principles, Modelling and Applications of QRA Studies, Third Edit

Wikipedia contributors (2017a) 2009 Sayano–Shushenskaya power station accident. In: Wikipedia, Free Encycl. http://en.wikipedia.org/wiki/Fukushima_Daiichi_nuclear_disaster. Accessed 12 Aug 2017

Wikipedia contributors (2017b) Fukushima Daiichi nuclear disaster. In: Wikipedia, Free Encycl. https://en.wikipedia.org/w/index.php?title=Fukushima_Daiichi_nuclear_disaster&oldid=794134922. Accessed 13 Aug 2017

Yang M, Khan F, Amyotte P (2015) Operational risk assessment: A case of the Bhopal disaster. Process Saf Environ Prot 97:70–79. doi: 10.1016/j.psep.2015.06.001

Chapter 2

A REVIEW OF BAYESIAN BELIEF NETWORK USED IN PROCESS INDUSTRIES

2.1 Introduction

Process industries, including chemical plants emphasized by hazardous materials, provide nowadays necessities of society. These hazardous materials are treated and stored under high pressure/temperature conditions and can lead to fires, explosions, and financial losses. A chemical hazard is defined by (Reniers 2010) as a set of circumstances that may result in harmful consequences. The latter measured by its effect on human, asset, and environment. With the increasing growth of industrialization and density of population in the world, the accidents continue to rise rapidly perhaps the most famous accident recently occurred is the blowout of Macondo well on April 20, 2010, in the Gulf of Mexico. To avoid such accidents, it is necessary to raise the level of safety and security in these industries by reducing or better prevent their occurrence. To this end, many methodologies have been proposed and developed for risk assessment including both qualitative and quantitative analysis. A review of these methods for risk analysis in chemical process industries is presented by (Khan and Abbasi 1998) such as Hazard and operability analysis (HAZOP), Failure mode and effects analysis (FMEA), and What-if analysis for qualitative analysis. Also, Fault tree analysis (FTA) and Event tree analysis (ETA) to conduct the quantitative part of the study. Each of the mentioned techniques has its advantages, and the combination of the two approaches (qualitative and quantitative

analysis) is necessary to provide a good picture of the encountered risks.

Due to the development and the complexity of today's process industries, risk and safety analysis of the latter became more challenging and time-consuming. Recently, Bayesian networks (BN) or Bayesian belief networks (BBN) have been used widely for reliability, safety and risk analysis of complex systems (Bobbio et al. 2001)(Langseth and Portinale 2007)(Torres-Toledano and Sucar 1998). The features of BBN in uncertainty handling, probability updating, and dependency representation make it one of the proper tool to model the chemical and process industry. For examples, N. Khakzad and G. Reniers (Khakzad and Reniers 2016) applied Bayesian network and Multi-criteria decision analysis to risk-based design and decision-making in chemical plants to employ the principles of inherently safer design (ISD) and land use planning (LUP). The same authors develop a methodology Based on Bayesian network to estimate the total probability of major accidents and calculate on-site and off-site risks considering domino effects in chemical plants (Khakzad and Reniers 2015a). Furthermore, N. Khakzad (Khakzad 2015a) proposed a new methodology based on dynamic Bayesian network (DBN) that can model spatial and temporal escalation of domino effects within chemical process plants. Safety-Instrumented Systems (SIS) implemented in such plants to reduce the risks to a tolerable level are also modeled by using BN (Kannan 2007) (Zerrouki and Tamrabet 2015) and a probabilistic fault diagnosis approach based on fault tree analysis (FTA) and Bayesian network (BN) for SIS is present by Z. Chiremsel (Chiremsel et al. 2016). BN use Bayes' Theorem to update the prior belief of variables given observations of other variables. Bayes' Theorem have been successfully applied in the field of chemical and process plants for:

- Accident modeling (Rathnayaka et al. 2012)(Rathnayaka et al. 2013)(Al-Shanini et al. 2015)(Rathnayaka et al. 2011)(Rathnayaka et al. 2010);
- Risk assessment (Khakzad et al. 2014a)(Yun et al. 2009)(Thodi et al. 2010);
- Dynamic risk analysis (Wang et al. 2016a)(Kalantarnia et al. 2009)(Khakzad et al. 2012a).

Furthermore, BBN has been widely used to solve some problems in conventional methods of risk analysis by mapping these techniques into BBN. In (Bobbio et al. 2001) and (Khakzad et al. 2011), the authors convert FTA into BBN to overcome some limitations particularly in update probabilities, multi-state variables and dependent failures,

the same for Event tree analysis (ETA) (Bearfield et al. 2005) and the Bow-tie analysis (BTA) (Khakzad et al. 2013a).

In this study, chemical industries cover different industrial sectors, such as production of chemicals and the pharmaceutical industry. In addition, manufacturing industries, including cement, paints, varnishes, soaps, etc., are also considered. The main element in these plants is the handling of chemicals in high pressure/temperature (Reniers 2010). These companies can be divided into 3 types:

- industries trait chemical materials;
- industries store chemical materials;
- and companies transport hazardous materials.

This chapter is divided into two parts; in the first part, we will briefly describe Bayesian belief networks (BBNs) and present a brief statistical review of the use of Bayesian networks in the chemical and process industry within the last decade. In the second part, a case study of the oil industry is used to demonstrate the application of BBN. Firstly, HAZOP analysis is used to identify the causes, the consequences of possible accidents and the safety Barriers implemented to mitigate the dangerous consequences. Secondly, BN analysis is established based on ET to investigate the performance of the safety barriers in the gas facility, the outcomes from the BN analysis are compared with the risk acceptance criteria. This latter defined as upper limits of acceptable risks that help to make a decision about the outcomes of the accidents. If the latter exceed the tolerable level, some measures of protections and preventions are proposed to improve the safety of the facility.

2.2 Bayesian Networks technique (BNs)

Bayesian belief network is a graphical model that is widely used in risk and reliability domains (Langseth and Portinale 2007). BN is a directed acyclic graph (DAG) that permits a probabilistic relationship among a set of variables (Pearl 1988), each node represents a variable, and the arcs indicate direct probabilistic relations between the connected nodes (Weber and Jouffe 2006) as shown in Figure 2.1, the arcs are directed from the parent node (A, B) to the child node (C). Each node in the BN has a conditional probability table (CPT) illustrating the relation cause- effect between nodes.

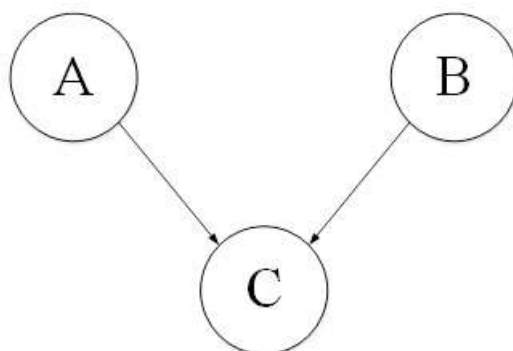

Figure 2.1: Example of BN model.

According to the conditional independence and the chain rule, BNs represent the joint probability distribution $P(X)$ of variables $X = \{X_1, X_2, \dots, X_n\}$ of any Bayesian networks as:

$$P(X) = \prod_{i=1}^n P(X_i \setminus \text{parents}(X_i)) \quad (2.1)$$

BNs can update the prior probability of any events given new information (posterior probability), called evidence M taking advantage of Bayes ‘theorem:

$$P(X \setminus M) = \frac{P(X, M)}{P(M)} = \frac{P(X, M)}{\sum_X P(X, M)} \quad (2.2)$$

Note that $P(X, M)$ is the probability of both X and M occurring, which is the same as the probability of X occurring times the probability that M occurs given that X occurred: $P(M \mid X) \times P(X)$

These two equations are the essential of BN, equation 2.1 is used to calculate the joint probability distribution and equation 2.2 to update the prior probability. BN is widely used for both qualitative and quantitative assessment. The qualitative phase identifies by a network structure while the quantitative analysis is represented by conditional probability tables associated with each node. The ability of BN to perform diagnostic and predictive analysis makes it suitable for quantitative risk analysis (Bhandari et al. 2015).

2.3 Collect of Data

The data used in the present study was derived from different sources such as; Google Scholar, Research Gate (RG) and National System of Online Documentation (SNDL) (2006-2016) using key words such as; “Bayesian Network”, “chemical plans”, “safety

analysis”, “risk assessment” and “process safety” as the search topics, a total 114 publications were found in the database. We will review, categorize, and summarize the technical articles published only in scientific journals of Science Citation Index Expanded (conference proceedings and books chapters are excluded). Only the technical articles that have a direct relationship with our study are chosen.

2.4 Overview on the application of BBN in risk analysis and accident modeling in chemical plants

Table 2.1 shows some of the recent reviews of Chemical Plants and Bayesian Networks in reliability and safety analysis. As can be noted, the interest in providing the safety in chemical plants increased mainly due to high consequence of the accidents caused by such plants. Also, it can be noticed from the same table that Bayesian networks (BN) have frequently been used to conduct an accident modeling and risk analysis in chemical and process industry.

Table 2.1: Different review of Chemical Plants and Bayesian Networks in reliability and safety analysis

Authors (Reference)	Chemical Plants	Bayesian Networks
L. Mkrtchyan et al.(Mkrtchyan et al. 2015)		×
P. Weber et al. (Weber et al. 2012)		×
N. Khakzad and G. Reniers (Khakzad and Reniers 2015b)	×	
N. Khakzad et al. (Khakzad et al. 2016b)	×	×
E. De Rademaeker et al. (De Rademaeker et al. 2014)	×	×
F. Khan et al. (Khan et al. 2015)	×	×
J. Li et al. (Li et al. 2016a)	×	
V. Villa et al. (Villa et al. 2016)	×	×

We can notice from Figure 2.2 that the beginning of publication in this field was tin due mainly to the preference of the authors on the conventional techniques such as FTA, ET, and BT. These techniques are characterized by ease of representation whether qualitative or quantitative. Nevertheless, the aforementioned techniques suffer from their static structure and should couple with other methods (e.g. fuzzy logic, Bayes’ theorem...) to

handle dynamically the problem encountered in the system study.

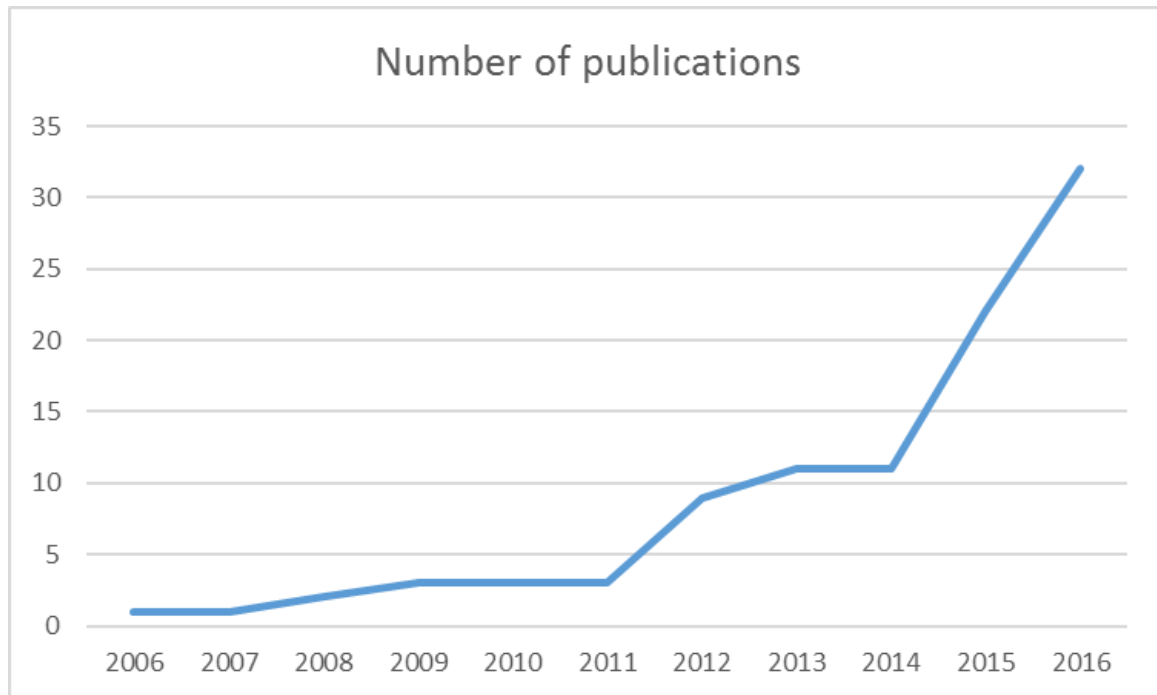

Figure 2.2: Time distribution of the publications of BBN used in the chemical plants in the last decade

In 2011, after the comparison made by khakzad (Khakzad et al. 2011) that compare FTA and BN in safety analysis of process facilities and the results that showed the advantages of BN compared to FT, we notice a significant increase in the number of publications. Moreover, another important factor is the blowout of Macondo well in the Gulf of Mexico 2010. This accident changed the look at the safety culture in these industries since it has become more complicated. Also. These manufactories deal with hazardous materials in high-pressure, high-temperature conditions caused a different type of risks at transportation and storage phase, which need a proper technique for safety assessment and decision-making. Compared with the other methods such as FTA and ETA in the same field, BBN can easily represent the complex systems due to its flexible structure, which explains the ascending trend of the publications that used BBN to deal with the complexity of chemical plants in the last decade.

A huge increase from Figure 2.2 can be noticed starting from 2013 and 2014, which is referred to another publication in the field. In this publication, Nima Khakzad et al. (Khakzad et al. 2013a) discuss the advantages of Bayesian networks over Bow-tie analysis for safety analysis of process systems. The ability of BN to represent the dependencies be-

tween different events in the model makes it suitable for risk analysis of complex systems. Moreover, benefit from Bayes theorem, BN can dynamically update probabilities to perform Dynamic safety analysis. The authors also discuss the use of probability adapting, rather than probability updating to dynamically revise the prior probability of accident components. From Table 2.1, we can notice that the publications after 2013 were mainly based on the use of both BT and BN to provide a better presentation of the accident scenario and to update dynamically the different events in the model.

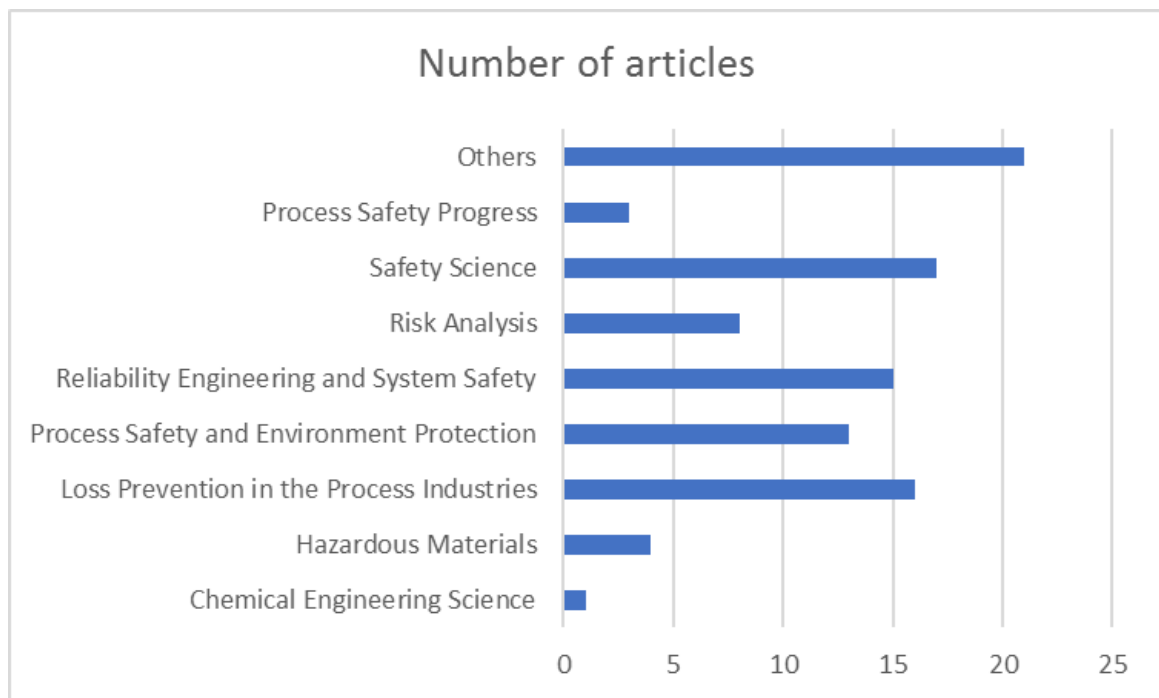

Figure 2.3: Journal distribution of the publications of BBN used in the chemical plants in the past ten years

Figure 2.3 displays the journals containing the publications that used BBN for different field such as; risk analysis or accident modeling in chemical plants. As can be noted, a vast majority of the papers has appeared in the safety journals instead of chemical journals. The majority of publications has appeared in “*Science direct*” journals such as “*Safety science*” with 17 publications, “*Loss Prevention in the Process Industries*” with 16 publications, “*Reliability Engineering and System Safety*” with 15 publications, and “*Process Safety and Environment Protection*” with 13 publications.

Table 2.2: Literature of Bayesian Belief Network (BBN) method (2006-2016) used in chemical plants and process industries

Article	BN	Application to	Goal
(Khakzad 2015a)	DBN	Hypothetical fuel storage plant	vulnerability analysis and domino effects of chemical process plants
(Khakzad et al. 2016a)	DBN	A large fuel storage plant comprising 39 atmospheric storage tanks containing gasoline	
(Khakzad and Reniers 2015c)	BN	Fireproofing of a hypothetical fuel storage plant	
(Yuan et al. 2016)	BN	A dust explosion at CTA Acoustics, Inc., KY, U.S	
(Khakzad et al. 2012b)	BN	Storage tanks on a tank farm	
(Khakzad et al. 2014c)	BN	4 identical atmospheric storage tanks	
(Khakzad and Reniers 2015a)	BN	A fuel storage plant with pool fire as the dominant accident scenario	
(Khakzad and Reniers 2015d)	BN	chemical storage plants	Safety and Risk analysis
(Goerlandt and Montewka 2015)	BN	Oil spills from collisions with oil tankers	
(Martins et al. 2014)	Hy-BN	Regasification System of LNG Onboard a Floating Storage and Regasification Unit	
(Clark and Besterfield-Sacre 2009)	BN	Hazmat transport	
(Ren et al. 2009)	FBN	Collision risk between a Floating Production, Storage and Offloading (FPSO) unit	
(Zerouali et al. 2016)	BT & BN	Fire and Explosion Pipeline in the industrial zone of Skikda	

(Pasman and Rogers 2013)	LOPA & BN	Batch polymerization reactor
(Khakzad et al. 2015)	ET & BN	Offshore blowouts in the Gulf of Mexico
(Khakzad et al. 2014d)	Hi-BN	Offshore blowouts in the Gulf of Mexico
(Bhandari et al. 2015)	BN	Deepwater MPD and UBD operations
(Yuan et al. 2015a)	BT & BN	Dust explosion accident at a wool factory in Vigliano Biellese, Biella, Italy (2001).
(Hanea and Ale 2009)	BN	Fire safety
(Khakzad et al. 2013c)	DTBN	Heat exchanger explosion occurred in 2008 at the Goodyear Tire and Rubber Company plant in Houston, Texas, U.S.
(Yuan et al. 2015b)	BN	Aluminum dust explosion occurred in October 2003 at Hayes Lemmerz International, Huntington, Indiana, US. ³
(Abimbola et al. 2016)	BT & BN	Well integrity of oil and gas reservoirs during casing and cementing operations.
(Khakzad et al. 2011)	FT & BN	The performance of a feeding control system transferring propane from a propane evaporator to a scrubbing column
(Abimbola et al. 2015)	BT and BN	Managed pressure drilling
(Smith et al. 2017)	FT, BN & FRAM	Propane feed control system
(Khakzad et al. 2013b)	BT & OOBN	Offshore drilling operations

(Li et al. 2016b)	BT & OOBN	Submarine oil and gas pipeline		
(van Staalduinen et al. 2017)	BT & BN	Liquefied Natural Gas (LNG) plant		
(Abimbola and Khan 2016)	BN	Drilling Operations		
(Khakzad and Reniers 2016)	BN	A hypothetical chemical storage plant including four similar atmospheric storage tanks		
(Tolo et al. 2016)	eBN	Nuclear power station of Sizewell B in East Anglia (UK)		
(Kabir et al. 2015)	FT & FBBN	Oil and gas pipelines	Risk assessment	
(Duan et al. 2016)	BN	Cryogenic Liquid Hydrogen Filling System		
(Naderpour et al. 2014)	DBN	A tank used for mixing flammable liquids from US Chemical Safety Board (CSB)		
(Khan et al. 2016)	HBLF	Tennessee Eastman process and a Wind turbine system loss production by icing		
(Khakzad et al. 2013a)	BT & BN	A vapor cloud ignition at Universal Form Clamp, Inc., Bellwood, Illinois, U.S. on June 14, 2006		
(Zarei et al. 2017)	BT & BN	Natural gas stations		
(Yang et al. 2015a)	BN	The Bhopal accident		
(Yu and Rashid 2013)	DBN	Continuous stirred tank reactor system and the Tennessee Eastman chemical process		Fault detection and fault diagnosis
(Gonzalez et al. 2012)	DBN	An oil sands process		

(Vileiniskis et al. 2016)	BBN	A three-phase separator	
(Hu et al. 2015)	DBN	A common fluid catalytic cracking unit (FCCU)	
(Yu et al. 2015)	BN	A simple multivariate process and the Tennessee Eastman chemical process	
(Verron et al. 2010)	BN	A hot forming process and the Tennessee Eastman Process	
(Widarsson and Dotzauer 2008)	BN	recovery boiler	
(Cai et al. 2015)	BN & DBN	FCCU plant in the Petrochemical company	
(Bhandari et al. 2016)	BN	Process operation on a typical offshore platform	Maintenance area
(Gran et al. 2012)	BN	Major offshore process equipment	
(Jones et al. 2010)	BN	A factory producing carbon black in the UK	
(Ait Mokhtar et al. 2016)	BN	Turbo-pump in oil industry	
(Hu et al. 2012)	DBN & HAZOP	A gas turbine compressor system	
(Vinnem et al. 2012)	BBN	Major process equipment on offshore petroleum installations	
(Abbassi et al. 2016)	BN	A power supply failure in a thermal power plant	
(Cai et al. 2013)	PFT, BN & DBN	Human factors on offshore blowouts	
(Martins and Maturana 2013)	BBN	Human reliability analysis of an oil tanker operation focusing on collision accidents	
(Musharraf et al. 2016)	BN	Offshore emergency evacuation	

(Garcia-Herrero et al. 2013)	BN	Safety culture and organizational culture Nuclear power plant	
(Strand and Lundteigen 2016)	BN	Human factor influences on the blowout risk of well drilling operations	
(Musharraf et al. 2013)	BN	Human Reliability Analysis (HRA) during emergency conditions in an off-shore environment	
(Wang et al. 2011)	BN	Release of cargo vapors from chemical tanker and vapor cloud formed by Vinyl Chloride Monomer	
(Norazahar et al. 2015)	BN	safe evacuation operations on offshore installations in harsh environments	
(Li et al. 2012)	FBN	A leaking valve of auxiliary feed water system in a nuclear power plant	
(Badreddine and Amor 2013)	BT & BN	A major fire and explosion on tanker truck carrying hydrocarbon in TOTAL TUNISIA company (risk evaluation)	Different Applications
(Bouejla et al. 2014)	BN	Risk of piracy in Offshore oil infrastructure	
(Kannan 2007)	BN	High pressure separator (SIS)	
(Weber and Jouffe 2006)	DOOBN	A water heater system (Reliability estimation)	
(Wang et al. 2015)	BN	A scenario-based warning system design	
(Pasman and Rogers 2014)	BT & BN	Oil processing module on off-shore platform (Risk management)	
(Mori and Mahalec 2016)	Hybrid BN	Steel plates manufacturing	
(Helle et al. 2011)	BN	Oil spills in The Gulf of Finland (the Baltic Sea)	
(Mori and Mahalec 2015)	Hybrid BN	Steel plates production	
(Wu et al. 2016)	BN	Mine water inrush	

(van Staal- duinen et al. 2016)	BN	An LNG processing plant, (Security Vulnerability Assessment)
---------------------------------------	----	---

We found from the literature about BN (Figure 2.4), that a set of 98 articles about the application of BN for the chemical plants and process industries. Most of the references found are about safety and risk analysis, and risk assessment with 21% and 17%, respectively.

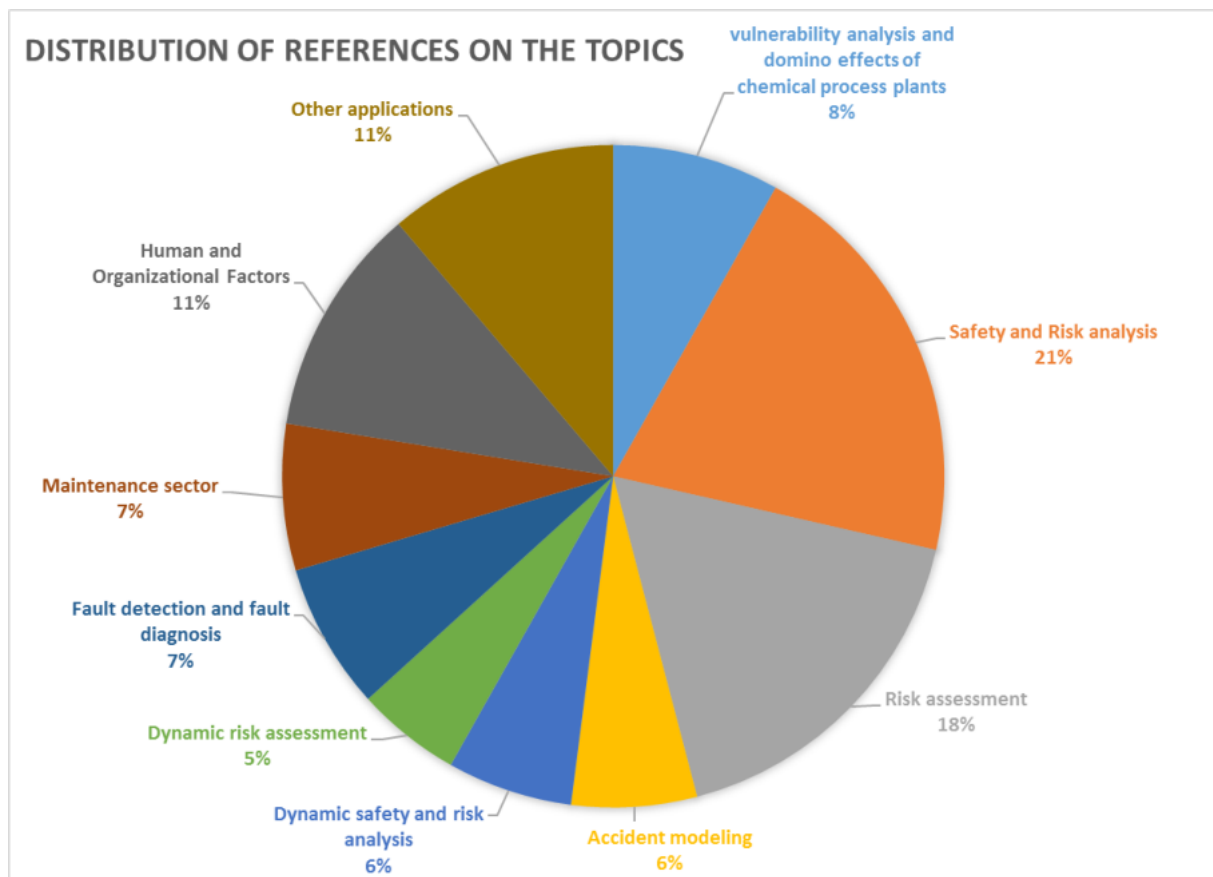

Figure 2.4: Distribution of references that used BN in the chemical plants and process industries (2006-2016).

In Table 2.2, we reviewed the different publications that used BBN and their application in the sector of chemical industry. We notice that different types of BN are used i.e. Dynamic Bayesian Network (DBN), Hybrid Bayesian Network, Hierarchical Bayesian Network (HIBN) and Object-Oriented Bayesian Networks (OOBN). Furthermore, BN was coupled or been mapped from other methods such as FT, ET and BT. In the following, we gave a brief description of different types of BNs:

2.4.1 Dynamic Bayesian Networks

Dynamic Bayesian network (DBN) is considered as an extension of static BN. Contrary to ordinary BN, DBN can integrate the temporal evolution of a set of random variables over a discretized time line in the modeling to describe the dynamic behaviours (Khakzad 2015b). DBN is represented by a sequence of time slices, these slices describing the system's state for each time step, the relation between variables in different slices denote a temporal probabilistic dependence between the variables (Hu et al. 2015). We can distinguish two types of dependence between variables; the arcs between nodes in the same time slice referred to as contemporaneous dependencies and the links between nodes in different period are called Non-contemporaneous dependencies (see Figure 2.4, black arcs represent contemporaneous dependencies and the red ones represent Non-contemporaneous dependencies). It is important to note that in DBN, the nodes are connected not only on its parents at the same time slice but also on its parents and itself at previous time slices (Khakzad et al. 2016a). Usually, DBN is defined as a pair (B_1, B_{\rightarrow}) , where B_1 and B_{\rightarrow} represent the prior $P(X_t)$, and B_{\rightarrow} represents the transition probability $P(X_t \setminus X_{t-1})$ as a two-slice temporal BN, respectively, (see equation 2.3).

$$P(X_t \setminus X_{t-1}) = \prod_{i=1}^N P(X_t^i \setminus Pa(X_t^i)) \quad (2.3)$$

Where, X_t^i denotes the i th node at time t ($i = 1, 2, \dots, N$) and $Pa(X_t^i)$ denotes its parents in the same networks.

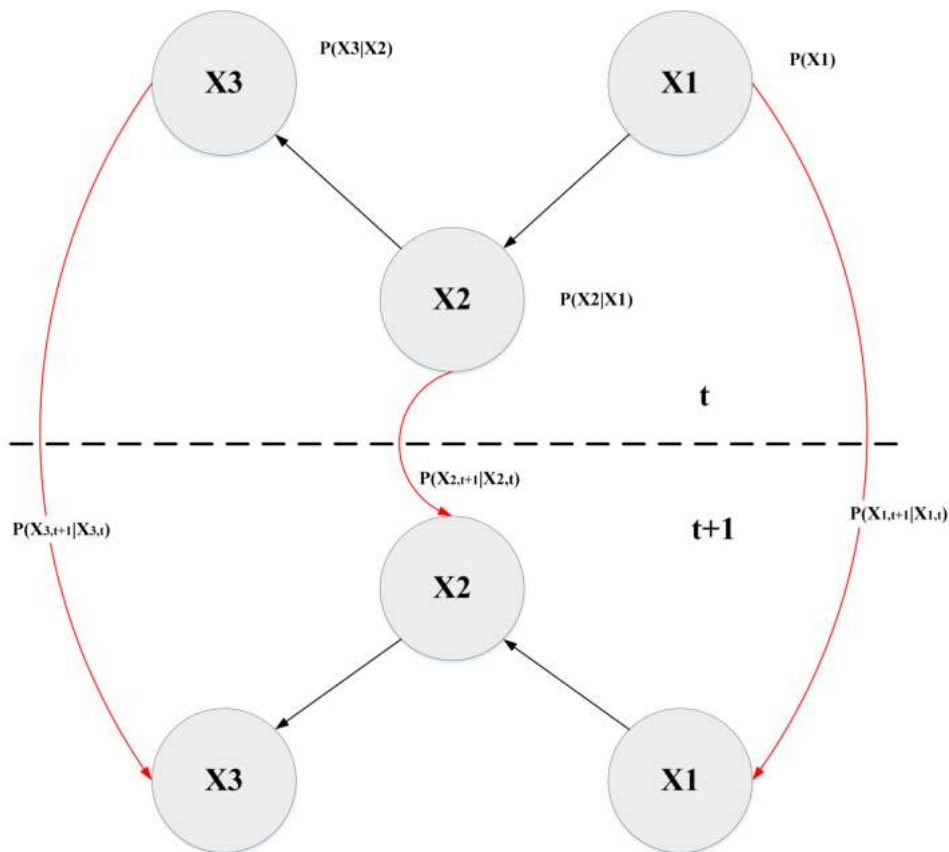

Figure 2.5: An illustrative example of dynamic Bayesian network for three variables.

In the following, we will present the recent contributions that used DBN in field of process industries and chemical plants taken from Table 2.2:

Baoping Cai et al. (Cai et al. 2013) propose a methodology to translate pseudo-fault tree into Bayesian networks and dynamic Bayesian networks taking repair into consideration. The proposed methodology applied for quantitative risk assessment of human factors on offshore blowouts. It is shown that BN is suitable methods for reliability assessment of human factors due to its ability to perform predictive analysis as well as diagnostic analysis.

Jie Yu and Mudassir Rashid (Yu and Rashid 2013) applied a novel networked process monitoring, fault propagation identification, and root cause diagnosis approach to a continuous stirred tank reactor system and the Tennessee Eastman chemical process. This approach used a dynamic Bayesian network-based networked process monitoring and diagnosis to detect the abnormal events in chemical processes, identify the propagation pathways of faults throughout processes, and diagnose the root-cause variables of faulty operation.

Nima Khakzad (Khakzad 2015b) proposed a new methodology that can model Spatial and temporal escalation of domino effects within chemical process plants. The methodology based on dynamic Bayesian network (DBN). The latter is more effective than the ordinary BN since it can identify the most probable sequence of accidents rather than the most probable combination of accidents. An example of Hypothetical fuel storage plant is used to demonstrate application of the proposed methodology.

Shubharthi Barua et al (Barua et al. 2016) proposes a dynamic Bayesian network for risk assessment of dynamic systems to represents the dependencies between variables graphically and captures their changes over time. Firstly, dynamic fault tree is developed for a chemical process system, then a procedure to map the developed dynamic fault tree into the Bayesian network. Moreover, a discrete time dynamic Bayesian network for dynamic operational risk assessment is demonstrated in this study using a case study of a holdup tank problem.

In Ruben Gonzalez et al. (Gonzalez et al. 2012) A methodology for the real-time detection and quantification of instrument gross error has been developed using dynamic Bayesian methods. The method entitled Dynamic Bayesian Gross Error Detection (DBGED) can estimates detected gross error magnitudes in real time that makes it easy to correct future measurements. A case study of an oil sands slurry preparation system illustrates the effectiveness of DBGED.

Ayele Yonas Zewdu et al. (Ayele et al. 2016) proposes a risk assessment methodology based on the Dynamic Bayesian Network to predict the future potential hazards in arctic offshore drilling waste handling practices. The efficiency of the methodology in updating the potential risks based on the current risk influencing factors such as snowstorms, atmospheric and sea spray icing information have been demonstrated Through a case study of an oil field development project in the Barents Sea (Norway).

Zengkai Liu et al. (Liu et al. 2015) developed a Dynamic Bayesian network of a parallel system with n components for reliability of subsea blowout preventer (BOP) stack with common cause failures (CCF) and imperfect coverage. Moreover, Sensitivity analysis is performed to evaluate the influences of failure rates and imperfect coverage on system reliability and availability.

Jinqiu Hu et al. (Hu et al. 2015) studies the fault propagation behaviour of process system. The authors used dynamic Bayesian network (DBN) to represent the relationships between risk factors, to identify the root causes that lead to the accident abnormal, and consider all safety measures. The effectiveness of the model is illustrated using common fluid catalytic cracking unit (FCCU) from an oil refinery process.

In the study of Jinqiu Hu et al. (Hu et al. 2010) an integrated method for safety pre-warning proposed to find the root hazard causes and corresponding consequences of a complex system, the method incorporate HAZOP, Markov process, and dynamic Bayesian networks (DBN) to indicate hidden hazards, potential consequence, and also predict future degradation trends in the long term. An example of the gas turbine compressor system demonstrates the methodology.

Jinqiu Hu et al. (Hu et al. 2012) present an approach for addressing both prognosis and opportunistic maintenance in process industry. Firstly, the proposed approach named DBN-HAZOP integrate the hazard interaction analysis in HAZOP study and automatic predictive reasoning mechanism in dynamic Bayesian networks (DBN) is used to build a prognosis model. Then, the authors introduce an opportunistic predictive maintenance (OPM) strategy for maintenance cost optimization, which considers failure probabilities, repair costs, down time cost and set-up cost. A real case study of gas turbine compressor systems demonstrated the DBN-HAZOP approach.

Nima Khakzad et al. (Khakzad et al. 2013c) used discrete-time Bayesian networks to solve dynamic fault trees based on new general formalism in process systems. A risk assessment and safety analysis of heat exchanger in the Goodyear accident show the effectiveness of the approach.

Nima Khakzad et al. (Khakzad 2015b) developed a graph theory approach for vulnerability analysis and domino effects of chemical plants. The results obtained from graph theory are validated using a dynamic Bayesian network (DBN) through a real case study of a large fuel storage plant.

2.4.2 Oriented Object Bayesian Networks

In this type of BN, we can distinguish two kinds of nodes; instance nodes and usual nodes. The latter are nodes that are mostly used in ordinary BN (or DBN). The instance nodes, which are the most important ones, represent another BN referred to as sub-network. Therefore, we can extract from above that OOBNs are constructed from a hierarchy of sub-networks with desired levels of abstraction with a view to reduce a large and complex BN to a simple model (Khakzad et al. 2013b). The new OOBN formed is a small size, an easy communication network with no identical structure (avoid repeating structure). Interface nodes containing input and output nodes are used to connect instance nodes with usual nodes. For more detail about OOBNs see (Kjaerulff and Madsen 2008)(in the book OOBNs are called object-oriented probabilistic networks OOPNs).

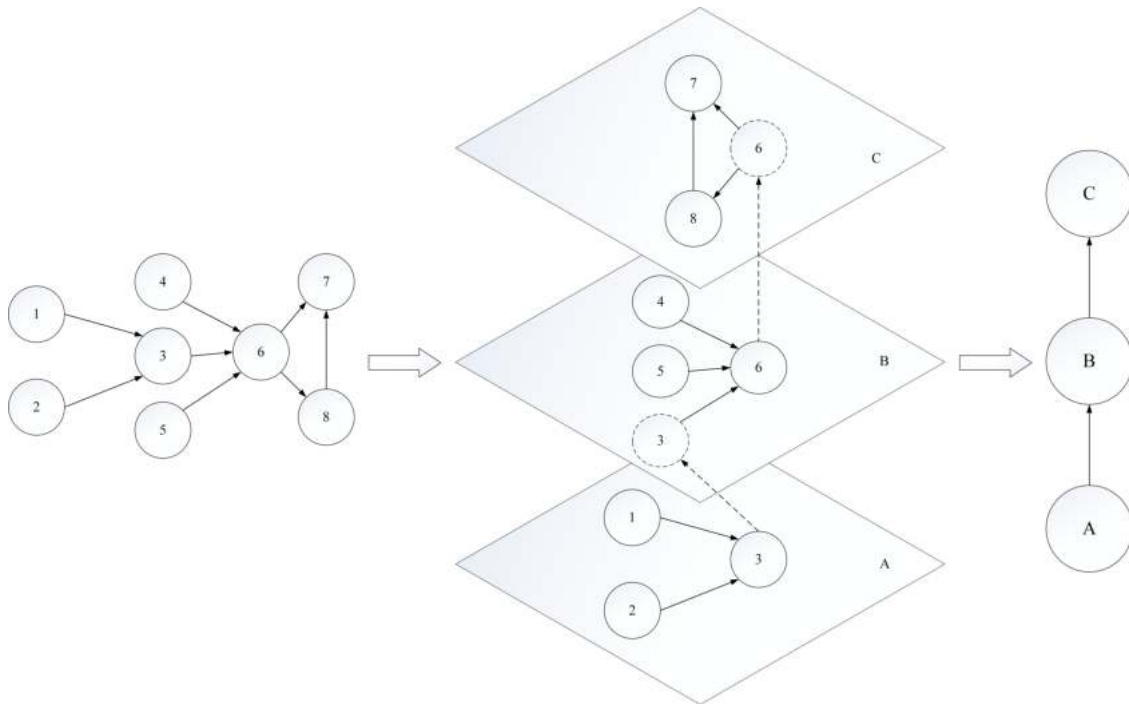

Figure 2.6: An ordinary BN in the left side is constructed using hierarchical structures with arbitrary levels of abstraction in the middle and then presented by instance nodes in the right.

An example of OOBN is depicted in Figure 2.6. As it can be seen, both node 3 and 6 are selected as the output nodes (presented in the network with blue border) in instance A and B, respectively. Also, node 3 and 6 are considered as the input nodes (presented in the network with dashed border) in instance B and C, respectively. The extracted BN is presented only by instance nodes A, B, and C (presented in right side of the network). The application of OOBN in the chemical plants and process industries are presented in the following paragraphs based on Table 2.2:

A fault detection and diagnostics of multiple failure modes based on oriented object Bayesian networks (OOBN) is proposed by Marius Vileiniskis et al. (Vileiniskis et al. 2016). The model can represent the interactions between component failure modes and process variables. The methodology is well applied to an oil processing plants, particularly in a three-phase separator.

Nima Khakzad et al. (Khakzad et al. 2013b) used both bow-tie (BT) and Bayesian network (BN) methods to build a quantitative risk analysis of drilling operations. The study shows the advantages of using BN over BT particularly when considering common cause failures, conditional dependencies, and updated probabilities. Moreover, the com-

plex and interlinked domain of well control is modelled using object-oriented Bayesian network (OOBN).

Xinhong Li et al. (Li et al. 2016b) build a dynamic risk-based model for leakage accident of submarine pipeline. In the study, the authors used Bow-tie to model the causal relationship between pipeline leakage and potential accident scenarios and Bayesian network analysis to overcome the limitations of BT in modeling uncertainties and conditional dependency. Then, Object-oriented Bayesian network is conducted by modularizing the primary Bayesian network.

2.5 Risk Analysis of a Case Study Using Bayesian Belief Networks

Over the last 70 years or more, the oil and gas sector witnessed great development from all sides. It had seen significant interest from researchers. Due to this evolution, many catastrophic incidents have occurred, among them: the Bhopal Gas Tragedy of 1984, which killed or maimed over 20, 000 persons. The Macondo Blowout (the Gulf of Mexico, 2010), the accident cost the lives of 11 men and millions of dollars, in 2004 an LNG release from unit 40 in Skikda (Algeria) caused 23 fatalities and 74 injuries (Chettouh et al. 2016). The impact of the accidents in this industry exceed the human, and the economies lose, it also causes enormous damage to the environment. To avoid these consequences, it is important to learn from past accidents to build a real picture of the front risks and to understand the mechanisms of accidents (Khan and Abbasi 1999). To this end, a risk analysis based on Bayesian belief networks is established in the next section to define the possible consequences of an undesired event in a case study of gas industry.

2.5.1 Description of the process

The module processing plant 2 (MPP2) in southern Algeria is a set of facilities for different functions (e.g. distillation columns, pumps, turbo-expander, heat exchangers) as shows Figure 2.7. These facilities are used to extract heavy hydrocarbons (condensate and liquefied petroleum gas) from the raw natural gas coming from the wells and produce various forms of gas (sales gas and reinjection).

The biphasic raw natural gas coming from 39 producer wells met in 9 collectors

then gather in the manifolds arrives towards the Boosting, whose role is to compress the raw gas from 93 kg/cm^2 to 120 kg/cm^2 , to recover the maximum of liquid hydrocarbons. Then it is distributed on three identical trains (A, B, C) with the same capacity of 20 million m^3/j to the diffuser D001 at a pressure of 120 kg/cm^2 and a temperature of 58 C° .

After the diffuser, the raw gas is cooled in the cooling tower E101 to 40 C° , the cooled gas passes through admission separator D101 where the gas separates from the water and liquid hydrocarbons, the water goes towards the evaporation basin. The gas originated from D101 with a pressure of 118 kg/cm^2 passes through the heat exchangers of gas/gas E103 and E102 where it cooled to -9 C° . The gas passes through the Joule-Thomson valve (PRCV108) where it undergoes a first isenthalpic expansion up to 100 kg/cm^2 and a temperature of -13 C° before reaching the high-pressure separator D102.

A glycol solution containing 80% mass is injected at the heat exchangers E102 and E103 to avoid the formation of hydrates that may block the Exchangers. The separator D102 separates the gas again into a solution of MEG (mono-ethylene glycol) and the liquid condensate. After absorbs the water, MEG solution is sent under pressure to the glycol regenerator section.

The gas from the D102 undergoes isentropic expansion in the turbine of "Turbo-Expenders K101", this last recover the energy, which occurs when high-pressure gas passes through the turbine to reduce its pressure at 67 kg/cm^2 and a temperature of -35 C° before passing through the cold separator D103. The gas cooled from D103 passes through the gas/gas exchanger E102 A/F calendar side to cool the raw gas and is heated itself to a temperature of 43 C° , then it is compressed to 74 kg/cm^2 on the compressor K101 and directed to the sales gas pipeline. The liquid hydrocarbons from the admission separator D101 are relaxed at the condensate separator rich D105 at 33 kg/cm^2 and 42 C° . The hydrocarbons recovered at D102 and D103 pass to the low-pressure separator D104 at a temperature -40 C° and a pressure 34 kg/cm^2 .

We are focusing on the separator tank D101, which is the first station of the gas in the facilities. The rest of the facilities will not be considered in this study.

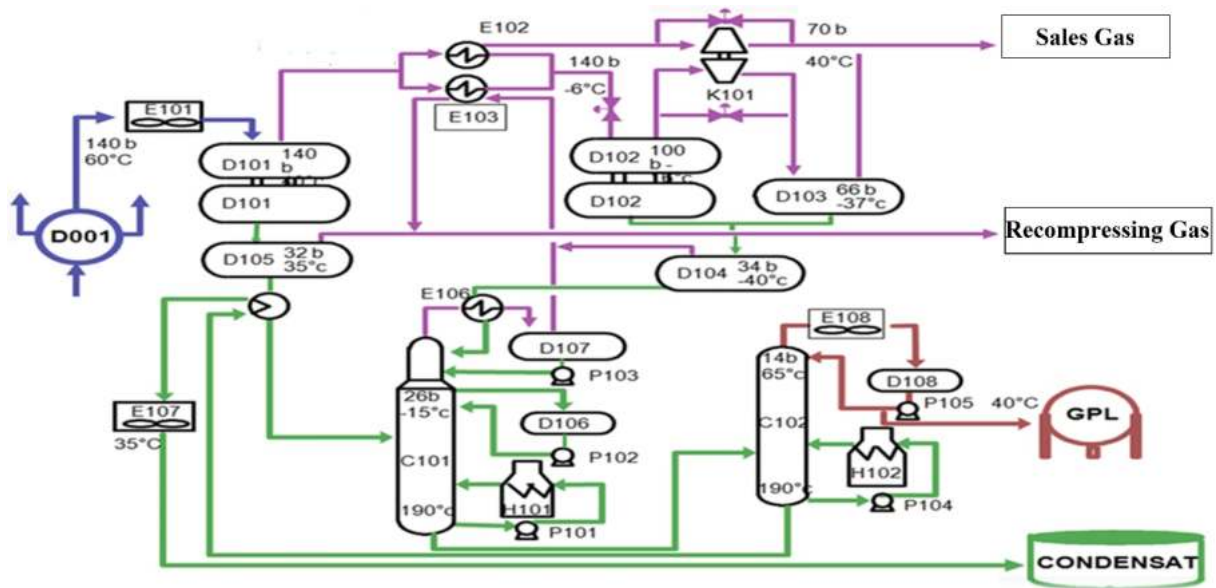

Figure 2.7: Simplified Process Flow Diagram of the facilities

2.5.2 Application of the methodology

To identify the potential scenarios, HAZOP (Hazard and Operability) is performed. HAZOP is a qualitative approach that is used for hazard identification and assessment. It studies the deviation from normal conditions to abnormal conditions, which allow its user to make intelligent guesses in the identification of hazard and operability problems (see chapter 1). Table 2.3 shows the potential scenarios that could lead to fire and explosion, process shutdown and environmental impacts and the different barriers that mitigate these consequences.

Table 2.3: Extracted HAZOP of the accident scenarios related to the process

No	Guide-word	Element	Deviation	Causes	Consequences	Protective Barriers
1	High	pressure	High pressure	Failure of the pressure indicator and controller PIC139	The pressure increases in the D101, rupture the admission separator D101, fire, explosion Flash fire, Pool fire, Vapor cloud explosion (VCE)	-High-pressure alarm PZAH102 - operator -High-pressure alarm PICAH 139 -Pressure indicators -Pressure relief valves (PCV-101 and HXC-102) -Manual valve XV-920 -Emergency evacuation system
2	High	Level	High level	Operator fails to manipulate the manual valve XV 920 (stay opened) Failure of the pressure indicator and controller PIC139	process shutdown Very high pressure inside the admission separator D101 can lead to fire and explosion High level in the D101 drive to HP Flare, the formation of frost in the exchanger tubes (E102) with the potential breaking of pipes, damage of the calendar with release gas into the atmosphere.	-High pressure alarm PICAH 139 in the case of pressure increase in the D101 (due to a rise in level) -Level indicators -High level alarms LICAH101/102: -operator (control room) actuates the liquid line bypass valves LICV 101A of D101 to D105 or LICV 101B to D003A -Level indicators

To keep the internal pressure limited to the design values, the pressure indicator and controller PIC139 opens the safety valve PCV139 when the pressure in the admission separator D101 rises (104.8 kg/cm^2). In the case of the failure of the safety valve PCV139 and the pressure inside D101 rises above 105.4 kg/cm^2 , the gas is discharged to the flare. To this end, the signal from the high-pressure sensor PIC144 opens the pressure relief valve PCV101 automatically. The failure of the latter leads to opening the second pressure relief valve HXC102. In addition, a high-pressure alarm PICAH 39 alerts the operator to close the manual valve XV-920 and takes appropriate actions when the safety valve fails. The different components related to the accident scenarios in the process are depicted in Table 2.5.

An event tree model is constructed to show the paths lead to the accident scenarios as Figure 2.8 depict. Thereafter, Bayesian network model is build based on the previous ET for the accident scenarios of the processing facility.

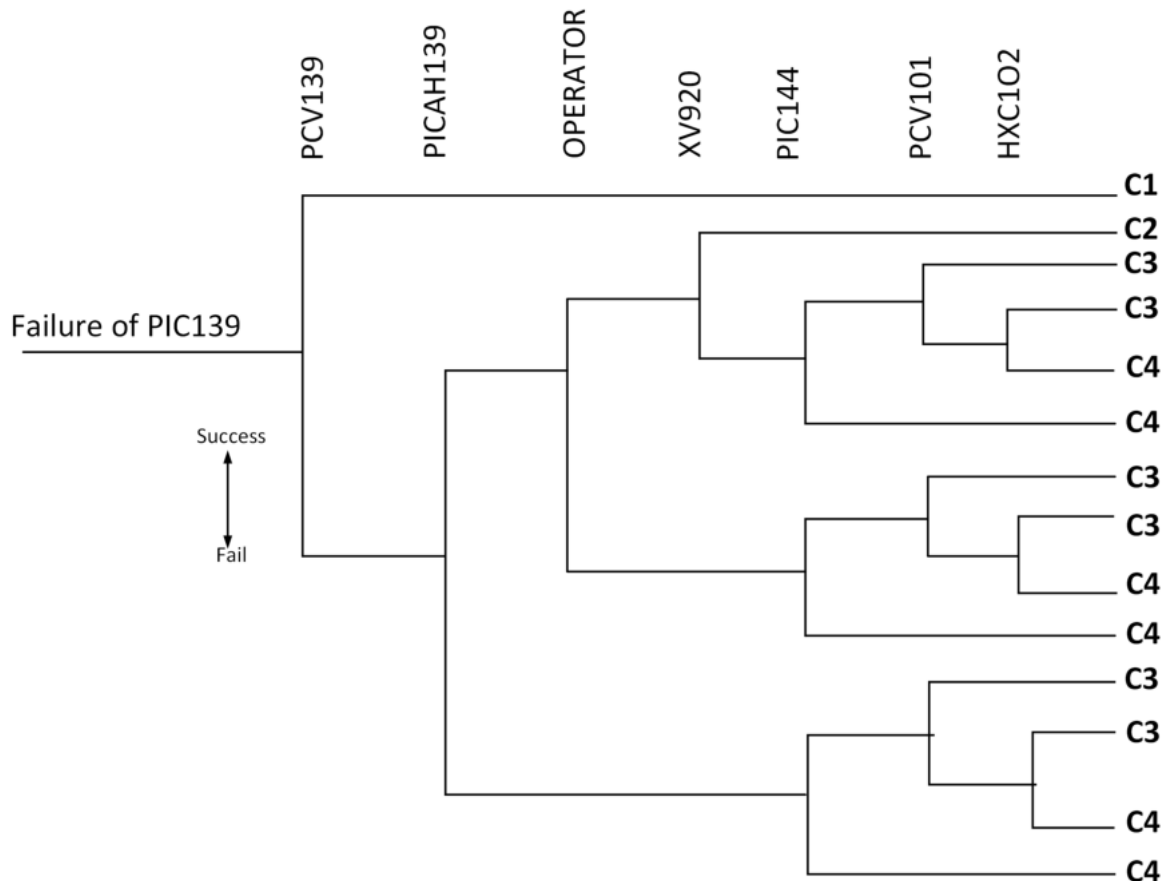

Figure 2.8: Event tree for the accident scenarios

The Bayesian network was constructed for the accident scenarios of the processing

facility. As can be seen in Figure 2.9, the relationship between components of the process are modeled using Hugin software (HUGIN 2015)(see Appendix A.1). Additional links are added in BN model, the arc from PIC139 to PCV139 and PICAH139 shows that PIC139 control the safety valve and, also send a signal to the alarm. Furthermore, PIC144 controls the pressure relief valves PCV101 and HXC102, another link between the pressure relief valves indicates that the valves should not work together in the same time (see Table 2.4). In the beginning, the initiating event and its frequency should be identified. Then the various barriers implemented in the system need to be recognized. Finally, the residual risk posed by the scenario needs to be checked with that of the tolerable limit, and one needs to make sure that the residual risk is within the acceptable limit (Kannan 2007). The maximum tolerable frequency for accident scenarios has defined to be $10^{-5}/year$. If the risk level exceeds the acceptable limit, additional measures of security must be proposed to improve the safety of the process. The failure frequency of pressure indicator and controller PIC139 is 0.1 failure per year (Chidi Benjamin Dibat 2010).

Table 2.4: CPT of the pressure relief valve HXC102

<i>PIC144</i>	<i>False</i>		<i>True</i>	
<i>PCV101</i>	<i>False</i>	<i>True</i>	<i>False</i>	<i>True</i>
<i>False</i>	1	1	2.12E-4	1
<i>True</i>	0	0	0.999788	0

In order to perform the calculations and determine the consequences of the scenario, the failure probabilities of the barriers and the other components are given in Table 2.5.

Table 2.5: Different components related to the accident scenarios in the process and their occurrence probabilities.

<i>Component</i>	<i>Description</i>	<i>Probability of failure</i>	<i>Reference</i>
PICAH139	Alarm	0.0183	(Stauffer and Clarke 2016)
Operator	Human error	0.01	(Stauffer and Clarke 2016)
PIC144	Pressure indicator and control	2.12E-4	(American Institute of Chemical engineers 1989)
PCV139	Safety valve	2.2E-4	(Chidi Benjamin Dibat 2010)
XV920	Manual valve	0.1393	(Khakzad et al. 2011)
PCV101	Pressure relief valve	0.1	(American Institute of Chemical engineers 1989)
HXC102	Pressure relief valve	0.1	(American Institute of Chemical engineers 1989)

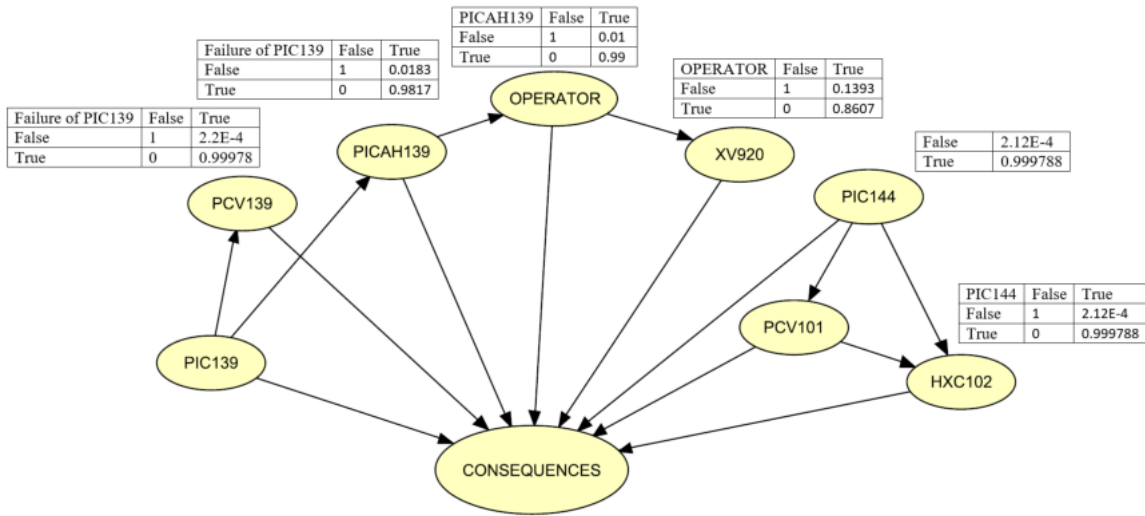

Figure 2.9: Bayesian network model for the accident scenarios

2.5.3 Results and discussion

The results of the BN model in Figure 2.9 are presented in Table 2.6. From HA-ZOP analysis three major consequences are distinguished; Pressure increase in the D101, Release gas into the atmosphere, and Fire and Explosion. In addition, another state indicates the safe situation named Situation under control. The four probabilities of possible consequences are calculated using BN and presented in Table 2.6. Compared with the risk acceptance criteria, which described previously, one consequence considered as dangerous situation for the process, which is “Pressure increase in the D101” with occurrence frequency of “ $1.82 \times 10^{-5}/year$ ”. To avoid such consequence, two High level alarms LICAH101/102 are installed in the process. Their role is to alert the operator (control room) to actuate whether opens the liquid line bypass valves LICV 101A of D101 to D105 or LICV 101B to D003A, which helps to decrease the pressure in the D101.

Some recommendations can be given to improve the safety of the process; another safety valve must be implemented redundancy with the safety valve PCV139.

Table 2.6: Frequencies of the consequences.

<i>Consequence</i>	<i>Description</i>	<i>Frequency (/Year)</i>
<i>C1</i>	Situation under control (Safe situation)	0.999978003
<i>C2</i>	Pressure increases in the D101	1.84E-5
<i>C3</i>	Release gas into the atmosphere	3.56E-6
<i>C4</i>	Fire and Explosion	3.7E-8

2.6 Conclusion

In this chapter, a brief statistical review of the use of Bayesian belief networks in the chemical and process industry within the last decade is presented. The results showed a significant increase of the publication in this field and the reasons are briefly discussed. A collection of 98 publications that is used BBN in chemical plants and process industries had been found in the literature, most of them is used to conduct risk assessment, safety and risk analysis. Furthermore, a case study of gas industry is used to demonstrate the application of BN, the latter is constructed based on ET. The study shows the suitability of Bayesian networks in the safety analysis of process facilities, BN can easily represent the interaction between different events (barriers) using arcs and fill the CPTs with the appropriate values unlike ET that require the independence of the events. Risk acceptance criteria is used to distinguish the most dangerous consequences. In the next chapter, we will discuss the advantages of Bayesian networks over one of the well-known methods that is Fault tree analysis.

Most of the content of this chapter is published in journal of failure analysis and prevention under title " *Bayesian Belief Network Used in the Chemical and Process Industry: A Review and Application*" (Zerrouki and Smadi 2017).

References

Abbassi R, Bhandari J, Khan F, Garaniya V, Chai S (2016) Developing a Quantitative Risk-based Methodology for Maintenance Scheduling Using Bayesian Network. *Chem Eng Trans* 48:235–240. doi: 10.3303/CET1648040

Abimbola M, Khan F (2016) Development of an integrated tool for risk analysis of drilling operations. *Process Saf Environ Prot* 102:421–430. doi: 10.1016/j.psep.2016.04.012

Abimbola M, Khan F, Khakzad N (2016) Risk-based safety analysis of well integrity operations. *Saf Sci* 84:149–160.

Abimbola M, Khan F, Khakzad N, Butt S (2015) Safety and risk analysis of managed pressure drilling operation using Bayesian network. *Saf Sci* 76:133–144. doi: 10.1016/j.ssci.2015.01.010

Adedigba SA, Khan F, Yang M (2016a) Dynamic safety analysis of process systems using nonlinear and non-sequential accident model. *Chem Eng Res Des* 111:169–183. doi: 10.1016/j.cherd.2016.04.013

Adedigba SA, Khan F, Yang M, Science S, Zhao L, Wang X, Qian Y, Fu Y, Xie M, Chin K, Ju X (2016b) Process accident model considering dependency among contributory factors. *Process Saf Environ Prot* 102:633–647. doi: 10.1016/j.psep.2016.05.004

Ait Mokhtar EH, Laggoune R, Chateauneuf A (2016) Imperfect Preventive Maintenance Policy for Complex Systems Based on Bayesian Networks. *Qual Reliab Eng Int*. doi: 10.1002/qre.2053

Al-Shanini A, Ahmad A, Khan F, Hassim M, Al-Shatri A (2015) Modeling the impact of natural and security hazards in an lng processing facility. *J Teknol* 75:17–25. doi: 10.11113/jt.v75.5158

Ale B, van Gulijk C, Hanea A, Hanea D, Hudson P, Lin PH, Sillem S (2014) Towards BBN based risk modelling of process plants. *Saf Sci* 69:48–56. doi: 10.1016/j.ssci.2013.12.007

American Institute of Chemical engineers (1989) GUIDELINES FOR PROCESS EQUIPMENT RELIABILITY DATA with data tables

Ayele YZ, Barabady J, Droguett EL (2016) Dynamic Bayesian Network-Based Risk Assessment for Arctic Offshore Drilling Waste Handling Practices. *J Offshore Mech Arct Eng* 138:51302. doi: 10.1115/1.4033713

Badreddine A, Amor N Ben (2013) A Bayesian approach to construct bow tie diagrams for risk evaluation. *Process Saf Environ Prot* 91:159–171. doi: 10.1016/j.psep.2012.03.005

Baksh AA, Khan F, Gadag V, Ferdous R (2015) Network based approach for predictive accident modelling. *Saf Sci* 80:274–287. doi: 10.1016/j.ssci.2015.08.003

Barua S, Gao X, Pasman H, Mannan MS (2016) Bayesian network based dynamic operational risk assessment. *J Loss Prev Process Ind* 41:399–410. doi: 10.1016/j.jlp.2015.11.024

Bearfield G, Marsh W, Rail A, Tower E, Road E (2005) Generalising Event Trees Using Bayesian Networks with a Case Study of Train Derailment George. *Lect Notes Comput Sci* 3688:52–66.

Bhandari J, Abbassi R, Garaniya V, Khan F (2015) Risk analysis of deepwater drilling operations using Bayesian network. *J Loss Prev Process Ind* 38:11–23. doi: 10.1016/j.jlp.2015.08.004

Bhandari J, Arzaghi E, Abbassi R, Garaniya V, Khan F (2016) Dynamic risk-based maintenance for offshore processing facility. *Process Saf Prog* 35:399–406. doi: 10.1002/prs.11829

Bobbio A, Portinale L, Minichino M, Ciancamerla E (2001) Improving the analysis of dependable systems by mapping Fault Trees into Bayesian Networks. *Reliab Eng Syst Saf* 71:249–260. doi: 10.1016/S0951-8320(00)00077-6

Bolsover A (2015) Real-time risk assessment and decision support. *Process Saf*

Prog 34:183–190. doi: 10.1002/prs.11702

Bouejla A, Chaze X, Guarnieri F, Napoli A (2014) A Bayesian network to manage risks of maritime piracy against offshore oil fields. *Saf Sci* 68:222–230. doi: 10.1016/j.ssci.2014.04.010

Cai B, Liu Y, Zhang Y, Fan Q, Liu Z, Tian X (2013) A dynamic Bayesian networks modeling of human factors on offshore blowouts. *J Loss Prev Process Ind* 26:639–649. doi: 10.1016/j.jlp.2013.01.001

Cai Z, Zhang L, Hu J, Yi Y, Wang Y (2015) Comprehensive alarm information processing technology with application in petrochemical plant. *J Loss Prev Process Ind* 38:101–113. doi: 10.1016/j.jlp.2015.08.010

Chettouh S, Hamzi R, Benaroua K (2016) Examination of fire and related accidents in Skikda Oil Refinery for the period 2002–2013. *J Loss Prev Process Ind* 41:186–193. doi: 10.1016/j.jlp.2016.03.014

Chidi Benjamin Dibat (2010) Determination of an optimum testing and inspection interval for pressure safety valves. University of Stavanger

Chiremsel Z, Nait Said R, Chiremsel R (2016) Probabilistic Fault Diagnosis of Safety Instrumented Systems based on Fault Tree Analysis and Bayesian Network. *J Fail Anal Prev* 16:747–760. doi: 10.1007/s11668-016-0140-z

Clark RM, Besterfield-Sacre ME (2009) A new approach to hazardous materials transportation risk analysis: Decision modeling to identify critical variables. *Risk Anal* 29:344–354. doi: 10.1111/j.1539-6924.2008.01163.x

De Rademaeker E, Suter G, Pasman HJ, Fabiano B (2014) A review of the past, present and future of the European loss prevention and safety promotion in the process industries. *Process Saf Environ Prot* 92:280–291. doi: 10.1016/j.psep.2014.03.007

Duan Y, Zhao J, Chen J, Bai G (2016) A risk matrix analysis method based on potential risk influence: A case study on cryogenic liquid hydrogen filling system. *Process Saf Environ Prot* 102:277–287. doi: 10.1016/j.psep.2016.03.022

Eleye-Datubo AG, Wall A, Wang J (2008) Marine and offshore safety assessment by incorporative risk modeling in a fuzzy-Bayesian network of an induced mass assignment paradigm. *Risk Anal* 28:95–112. doi: 10.1111/j.1539-6924.2008.01004.x

Garcia-Herrero S, Mariscal MA, Gutierrez JM, Toca-Otero A (2013) Bayesian network analysis of safety culture and organizational culture in a nuclear power plant. *Saf Sci* 53:82–95. doi: 10.1016/j.ssci.2012.09.004

Goerlandt F, Montewka J (2015) A framework for risk analysis of maritime transportation systems: A case study for oil spill from tankers in a ship-ship collision. *Saf Sci*

76:42–66. doi: 10.1016/j.ssci.2015.02.009

Gonzalez R, Huang B, Xu F, Espejo A (2012) Dynamic bayesian approach to gross error detection and compensation with application toward an oil sands process. *Chem Eng Sci* 67:44–56. doi: 10.1016/j.ces.2011.07.025

Gran BA, Bye R, Nyheim OM, Okstad EH, Seljelid J, Sklet S, Vatn J, Vinnem JE (2012) Evaluation of the Risk OMT model for maintenance work on major offshore process equipment. *J Loss Prev Process Ind* 25:582–593. doi: 10.1016/j.jlp.2012.01.001

Hanea D, Ale B (2009) Risk of human fatality in building fires: A decision tool using Bayesian networks. *Fire Saf J* 44:704–710. doi: 10.1016/j.firesaf.2009.01.006

Hanea DM, Jagtman HM, Ale BJM (2012) Analysis of the Schiphol Cell Complex fire using a Bayesian belief net based model. *Reliab Eng Syst Saf* 100:115–124. doi: 10.1016/j.ress.2012.01.002

Helle I, Lecklin T, Jolma A, Kuikka S (2011) Modeling the effectiveness of oil combating from an ecological perspective - A Bayesian network for the Gulf of Finland; the Baltic Sea. *J Hazard Mater* 185:182–192. doi: 10.1016/j.jhazmat.2010.09.017

Hu J, Zhang L, Cai Z, Wang Y, Wang A (2015) Fault propagation behavior study and root cause reasoning with dynamic Bayesian network based framework. *Process Saf Environ Prot* 97:25–36. doi: 10.1016/j.psep.2015.02.003

Hu J, Zhang L, Liang W (2012) Opportunistic predictive maintenance for complex multi-component systems based on DBN-HAZOP model. *Process Saf Environ Prot* 90:376–388. doi: 10.1016/j.psep.2012.06.004

Hu J, Zhang L, Ma L, Liang W (2010) An integrated method for safety pre-warning of complex system. *Saf Sci* 48:580–597. doi: 10.1016/j.ssci.2010.01.007

HUGIN (2015) HUGIN Expert software version 8.1. <http://www.hugin.com>.

Jones B, Jenkinson I, Yang Z, Wang J (2010) The use of Bayesian network modelling for maintenance planning in a manufacturing industry. *Reliab Eng Syst Saf* 95:267–277. doi: 10.1016/j.ress.2009.10.007

Kabir G, Sadiq R, Tesfamariam S (2015) A fuzzy Bayesian belief network for safety assessment of oil and gas pipelines. *Struct Infrastruct Eng* 1–16. doi: 10.1080/15732479.2015.1053093

Kalantarnia M, Khan F, Hawboldt K (2009) Dynamic risk assessment using failure assessment and Bayesian theory. *J Loss Prev Process Ind* 22:600–606. doi: 10.1016/j.jlp.2009.04.006

Kannan PR (2007) Bayesian networks: Application in safety instrumentation and risk reduction. *ISA Trans* 46:255–259. doi: 10.1016/j.isatra.2006.11.003

Khakzad N (2015a) Application of dynamic Bayesian network to risk analysis of domino effects in chemical infrastructures. *Reliab Eng Syst Saf* 138:263–272. doi: <http://dx.doi.org/10.1016/j.ress.2015.02.007>

Khakzad N (2015b) Application of dynamic Bayesian network to risk analysis of domino effects in chemical infrastructures. *Reliab Eng Syst Saf J* 138:263–272. doi: 10.11113/jt.v75.5158

Khakzad N, Khakzad S, Khan F (2014a) Probabilistic risk assessment of major accidents: application to offshore blowouts in the Gulf of Mexico. *Nat Hazards* 74:1759–1771. doi: 10.1007/s11069-014-1271-8

Khakzad N, Khakzad S, Khan F (2014b) Probabilistic risk assessment of major accidents: application to offshore blowouts in the Gulf of Mexico. *Nat Hazards* 74:1759–1771. doi: 10.1007/s11069-014-1271-8

Khakzad N, Khan F, Amyotte P (2012a) Dynamic risk analysis using bow-tie approach. *Reliab Eng Syst Saf* 104:36–44. doi: 10.1016/j.ress.2012.04.003

Khakzad N, Khan F, Amyotte P (2011) Safety analysis in process facilities: Comparison of fault tree and Bayesian network approaches. *Reliab Eng Syst Saf* 96:925–932. doi: 10.1016/j.ress.2011.03.012

Khakzad N, Khan F, Amyotte P (2013a) Dynamic safety analysis of process systems by mapping bow-tie into Bayesian network. *Process Saf Environ Prot* 91:46–53. doi: 10.1016/j.psep.2012.01.005

Khakzad N, Khan F, Amyotte P (2013b) Risk-based design of process systems using discrete-time Bayesian networks. *Reliab Eng Syst Saf* 109:5–17. doi: 10.1016/j.ress.2012.07.009

Khakzad N, Khan F, Amyotte P (2013c) Quantitative risk analysis of offshore drilling operations: A Bayesian approach. *Saf Sci* 57:108–117. doi: 10.1016/j.ssci.2013.01.022

Khakzad N, Khan F, Amyotte P (2015) Major Accidents (Gray Swans) Likelihood Modeling Using Accident Precursors and Approximate Reasoning. *Risk Anal* 35:1336–1347. doi: 10.1111/risa.12337

Khakzad N, Khan F, Amyotte P, Cozzani V (2012b) Domino Effect Analysis Using Bayesian Networks. *Risk Anal* 33:292–306. doi: 10.1111/j.1539-6924.2012.01854.x

Khakzad N, Khan F, Amyotte P, Cozzani V (2014c) Risk Management of Domino Effects Considering Dynamic Consequence Analysis. *Risk Anal* 34:1128–1138. doi: 10.1111/risa.12158

Khakzad N, Khan F, Paltrinieri N (2014d) On the application of near accident

data to risk analysis of major accidents. *Reliab Eng Syst Saf* J 126:116–125. doi: 10.1016/j.res.2014.01.015

Khakzad N, Reniers G (2016) Application of Bayesian network and multi-criteria decision analysis to risk-based design of chemical plants. *Chem Eng Trans* 48:223–225. doi: 10.3303/CET1648038

Khakzad N, Reniers G (2015a) Risk-based design of process plants with regard to domino effects and land use planning. *J Hazard Mater* 299:289–297. doi: 10.1016/j.jhazmat.2015.06.020

Khakzad N, Reniers G (2015b) Protecting Chemical Plants against Terrorist Attacks: A Review. *J Soc.* doi: 10.4172/2167-0358.1000142

Khakzad N, Reniers G (2017) Cost-effective allocation of safety measures in chemical plants wrt land-use planning. *Saf Sci* 97:2–9.

Khakzad N, Reniers G (2015c) Using graph theory to analyze the vulnerability of process plants in the context of cascading effects. *Reliab Eng Syst Saf* 143:63–73. doi: 10.1016/j.res.2015.04.015

Khakzad N, Reniers G, Abbassi R, Khan F (2016a) Vulnerability analysis of process plants subject to domino effects. *Reliab Eng Syst Saf* 154:127–136. doi: 10.1016/j.res.2016.06.004

Khakzad N, Yu H, Paltrinieri N, Khan F (2016b) Reactive Approaches of Probability Update Based on Bayesian Methods. In: Paltrinieri N, Khan F (eds) *Dynamic Risk Analysis in the Chemical and Petroleum Industry*, 1st edn. Elsevier, pp 51–61

Khan F, Rathnayaka S, Ahmed S (2015) Methods and models in process safety and risk management: Past, present and future. *Process Saf Environ Prot* 98:116–147. doi: 10.1016/j.psep.2015.07.005

Khan F, Wang H, Yang M (2016) Application of loss functions in process economic risk assessment. *Chem Eng Res Des* 111:371–386. doi: 10.1016/j.cherd.2016.05.022

Khan FI, Abbasi S. (1998) Techniques and methodologies for risk analysis in chemical process industries. *J Loss Prev Process Ind* 11:261–277. doi: 10.1016/S0950-4230(97)00051-X

Khan FI, Abbasi S. (1999) Reply to comments on “Major accidents in process industries and an analysis of causes and consequences.” *J Loss Prev Process Ind* 14:85. doi: 10.1016/S0950-4230(00)00016-4

Kjaerulff UB, Madsen AL (2008) *Bayesian networks and influence diagrams*. Springer Sci Bus Media 200:114.

Langseth H, Portinale L (2007) Bayesian networks in reliability. *Reliab Eng Syst*

Saf 92:92–108. doi: 10.1016/j.ress.2005.11.037

Lees F. (2005) *Loss Prevention in the Process Industries*, Third edit. Butterworths, London

Li J, Reniers G, Cozzani V, Khan F (2016a) A bibliometric analysis of peer-reviewed publications on domino effects in the process industry. *J Loss Prev Process Ind.* doi: 10.1016/j.jlp.2016.06.003

Li P cheng, Chen G hua, Dai L cao, Zhang L (2012) A fuzzy Bayesian network approach to improve the quantification of organizational influences in HRA frameworks. *Saf Sci* 50:1569–1583. doi: 10.1016/j.ssci.2012.03.017

Li X, Chen G, Zhu H (2016b) Quantitative risk analysis on leakage failure of submarine oil and gas pipelines using Bayesian network. *Process Saf Environ Prot* 103:163–173. doi: 10.1016/j.psep.2016.06.006

Liu Z, Liu Y, Cai B, Zhang D, Zheng C (2015) Dynamic Bayesian network modeling of reliability of subsea blowout preventer stack in presence of common cause failures. *J Loss Prev Process Ind* 38:58–66. doi: 10.1016/j.jlp.2015.09.001

Martins MR, Maturana MC (2013) Application of Bayesian Belief networks to the human reliability analysis of an oil tanker operation focusing on collision accidents. *Reliab Eng Syst Saf* 110:89–109. doi: 10.1016/j.ress.2012.09.008

Martins MR, Schleder AM, Drogue EL (2014) A methodology for risk analysis based on hybrid bayesian networks: Application to the regasification system of liquefied natural gas onboard a floating storage and regasification unit. *Risk Anal* 34:2098–2120. doi: 10.1111/risa.12245

Mkrtchyan L, Podofillini L, Dang VN (2015) Bayesian belief networks for human reliability analysis: A review of applications and gaps. *Reliab Eng Syst Saf* 139:1–5. doi: 10.1016/j.ress.2015.02.006

Mori J, Mahalec V (2016) Inference in hybrid Bayesian networks with large discrete and continuous domains. *Expert Syst Appl* 49:1–19. doi: 10.1016/j.eswa.2015.11.019

Mori J, Mahalec V (2015) Planning and scheduling of steel plates production. Part I: Estimation of production times via hybrid Bayesian networks for large domain of discrete variables. *Comput Chem Eng* 79:113–134. doi: 10.1016/j.compchemeng.2015.02.005

Musharraf M, Hassan J, Khan F, Veitch B, MacKinnon S, Imtiaz S (2013) Human reliability assessment during offshore emergency conditions. *Saf Sci* 59:19–27. doi: 10.1016/j.ssci.2013.04.001

Musharraf M, Smith J, Khan F, Veitch B, MacKinnon S (2016) Assessing offshore emergency evacuation behavior in a virtual environment using a Bayesian Network ap-

proach. *Reliab Eng Syst Saf* 152:28–37. doi: 10.1016/j.ress.2016.02.001

Naderpour M, Lu J, Zhang G (2014) A situation risk awareness approach for process systems safety. *Saf Sci* 64:173–189. doi: 10.1016/j.ssci.2013.12.005

Norazahar N, Khan F, Veitch B, MacKinnon S (2017) Prioritizing safety critical human and organizational factors of EER systems of offshore installations in a harsh environment. *Saf Sci* 95:171–181.

Ouazraoui N, Nait-said R, Bourareche M, Sellami I (2013) Layers of protection analysis in the framework of possibility theory. *J Hazard Mater* 262:168–178. doi: 10.1016/j.jhazmat.2013.08.042

Pasman H, Rogers W (2013) Bayesian networks make LOPA more effective, QRA more transparent and flexible, and thus safety more definable! *J Loss Prev Process Ind* 26:434–442. doi: 10.1016/j.jlp.2012.07.016

Pasman H, Rogers W (2014) How can we use the information provided by process safety performance indicators? Possibilities and limitations. *J Loss Prev Process Ind* 30:197–206. doi: 10.1016/j.jlp.2013.06.001

Pasman HJ, Rogers WJ (2012) Risk assessment by means of Bayesian networks: A comparative study of compressed and liquefied H₂ transportation and tank station risks. *Int J Hydrogen Energy* 37:17415–17425. doi: 10.1016/j.ijhydene.2012.04.051

Pearl J (1988) Probabilistic reasoning in intelligent systems: Networks of plausible inference. MORGAN KAUFMANN PUBLISHERS, INC., San Francisco, California

Rathnayaka S, Khan F, Amayotte P (2013) Accident modeling and risk assessment framework for safety critical decision-making: application to deepwater drilling operation. *J Risk Reliab* 227:86–105.

Rathnayaka S, Khan F, Amyotte P (2011) SHIPP methodology: Predictive accident modeling approach. Part I: Methodology and model description. *Process Saf Environ Prot* 89:151–164.

Rathnayaka S, Khan F, Amyotte P (2012) Accident modeling approach for safety assessment in an LNG processing facility. *J Loss Prev Process Ind* 25:414–423. doi: 10.1016/j.jlp.2011.09.006

Rathnayaka S, Khan F, Amyotte P (2010) SHIPP methodology: Predictive accident modeling approach . Part II . Validation with case study. *Process Saf Environ Prot* 89:75–88. doi: 10.1016/j.psep.2010.12.002

Ren J, Jenkinson I, Wang J, Xu DL, Yang JB (2009) An Offshore Risk Analysis Method Using Fuzzy Bayesian Network. *J Offshore Mech Arct Eng* 131:1–28. doi: 10.1115/1.3124123

Reniers GLL (2010) Multi-plant Safety and Security Management in the Chemical and Process Industries. WILEY-VCH Verlag GmbH & Co. KGaA, Weinheim

Shabarchin O, Tesfamariam S (2016) Internal corrosion hazard assessment of oil & gas pipelines using Bayesian belief network model. *J Loss Prev Process Ind* 40:479–495. doi: 10.1016/j.jlp.2016.02.001

Smith D, Veitch B, Khan F, Taylor R (2017) Understanding industrial safety: Comparing Fault tree, Bayesian network, and FRAM approaches. *J Loss Prev Process Ind* 45:88–101. doi: 10.1016/j.jlp.2016.11.016

Song G, Khan F, Wang H, Leighton S, Yuan Z, Liu H (2016) Dynamic occupational risk model for offshore operations in harsh environments. *Reliab Eng Syst Saf* 150:58–64.

Strand G, Lundteigen MA (2016) Human factors modelling in offshore drilling operations. *J Loss Prev Process Ind* 43:654–667. doi: 10.1016/j.jlp.2016.06.013

Tan Q, Chen G, Zhang L, Fu J, Li Z (2014) Dynamic accident modeling for high-sulfur natural gas gathering station. *Process Saf Environ Prot* 92:565–576. doi: 10.1016/j.psep.2013.03.004

Thodi PN, Khan FI, Haddara MR (2010) The development of posterior probability models in risk-based integrity modeling. *Risk Anal* 30:400–420. doi: 10.1111/j.1539-6924.2009.01352.x

Tolo S, Patelli E, Beer M (2016) Robust vulnerability analysis of nuclear facilities subject to external hazards. *Stoch Environ Res Risk Assess.* doi: 10.1007/s00477-016-1360-1

Torres-Toledano JG, Sucar L (1998) Bayesian Networks for Reliability Analysis of Complex Systems. *Prog Artif Intell - IBERAMIA* 98 1484:465.

van Staalduinen MA, Khan F, Gadag V (2016) SVAPP methodology: A predictive security vulnerability assessment modeling method. *J Loss Prev Process Ind* 43:397–413. doi: 10.1016/j.jlp.2016.06.017

van Staalduinen MA, Khan F, Gadag V, Reniers G (2017) Functional quantitative security risk analysis (QSRA) to assist in protecting critical process infrastructure. *Reliab Eng Syst Saf* 157:23–34. doi: 10.1016/j.ress.2016.08.014

Verron S, Li J, Tiplica T (2010) Fault detection and isolation of faults in a multivariate process with Bayesian network. *J Process Control* 20:902–911. doi: 10.1016/j.jprocont.2010.06.001

Vileiniskis M, Remenyte-Prescott R, Rama D, Andrews J (2016) Fault detection and diagnostics of a three-phase separator. *J Loss Prev Process Ind* 41:215–230. doi: 10.1016/j.jlp.2016.03.021

Villa V, Paltrinieri N, Khan F, Cozzani V (2016) Towards dynamic risk analysis: A review of the risk assessment approach and its limitations in the chemical process industry. *Saf Sci* 89:77–93. doi: 10.1016/j.ssci.2016.06.002

Vinnem JE, Bye R, Gran BA, Kongsvik T, Nyheim OM, Okstad EH, Seljelid J, Vatn J (2012) Risk modelling of maintenance work on major process equipment on offshore petroleum installations. *J Loss Prev Process Ind* 25:274–292. doi: 10.1016/j.jlp.2011.11.001

Wang H, Khan F, Ahmed S (2015) Design of scenario-based early warning system for process operations. *Ind Eng Chem Res* 54:8255–8265. doi: 10.1021/acs.iecr.5b02481

Wang H, Khan F, Ahmed S, Imtiaz S (2016a) Dynamic quantitative operational risk assessment of chemical processes. *Chem Eng Sci* 142:62–78. doi: 10.1016/j.ces.2015.11.034

Wang X, Zhu J, Ma F, Li C, Cai Y, Yang Z (2016b) Bayesian network-based risk assessment for hazmat transportation on the Middle Route of the South-to-North Water Transfer Project in China. *Stoch Environ Res Risk Assess* 30:841–857. doi: 10.1007/s00477-015-1113-6

Wang YF, Faghieh Roohi S, Hu XM, Xie M (2011) Investigations of Human and Organizational Factors in hazardous vapor accidents. *J Hazard Mater* 191:69–82. doi: 10.1016/j.jhazmat.2011.04.040

Wang YF, Xie M, Chin K, Fu XJ (2013) Accident analysis model based on Bayesian Network and Evidential Reasoning approach. *J Loss Prev Process Ind* 26:10–21. doi: 10.1016/j.jlp.2012.08.001

Weber P, Jouffe L (2006) Complex system reliability modelling with Dynamic Object Oriented Bayesian Networks (DOOBN). *Reliab Eng Syst Saf* 91:149–162. doi: 10.1016/j.ress.2005.03.006

Weber P, Medina-Oliva G, Simon C, Iung B (2012) Overview on Bayesian networks applications for dependability, risk analysis and maintenance areas. *Eng Appl Artif Intell* 25:671–682. doi: 10.1016/j.engappai.2010.06.002

Widarsson B, Dotzauer E (2008) Bayesian network-based early-warning for leakage in recovery boilers. *Appl Therm Eng* 28:754–760. doi: 10.1016/j.applthermaleng.2007.06.016

Wu J, Xu S, Zhou R, Qin Y (2016) Scenario analysis of mine water inrush hazard using Bayesian networks. *Saf Sci* 89:231–239. doi: 10.1016/j.ssci.2016.06.013

Wu W, Yang C, Chang J-C, Château P, Chang Y-C (2015) Risk assessment by integrating interpretive structural modeling and Bayesian network, case of offshore pipeline project. *Reliab Eng Syst Saf* 142:515–524. doi: 10.1016/j.ress.2015.06.013

Xin P, Khan F, Ahmed S (2017) Dynamic hazard identification and scenario map-

ping using Bayesian network. *Process Saf Environ Prot* 105:143–155. doi: 10.1016/j.psep.2016.11.003

Yang M, Khan F, Amyotte P (2015a) Operational risk assessment: A case of the Bhopal disaster. *Process Saf Environ Prot* 97:70–79. doi: 10.1016/j.psep.2015.06.001

Yang M, Khan F, Lye L, Amyotte P (2015b) Risk assessment of rare events. *Process Saf Environ Prot* 98:102–108. doi: 10.1016/j.psep.2015.07.004

Yeo CT, Bhandari J, Abbassi R, Garaniya V, Chai S, Shomali B (2016) Dynamic risk analysis of offloading process in floating liquefied natural gas (FLNG) platform using Bayesian Network. *J Loss Prev Process Ind* 41:259–269. doi: 10.1016/j.jlp.2016.04.002

Yu H, Khan F, Garaniya V (2015) Modified Independent Component Analysis and Bayesian Network-Based Two-Stage Fault Diagnosis of Process Operations. *Ind Eng Chem Res* 54:2724–2742. doi: 10.1021/ie503530v

Yu J, Rashid MM (2013) A Novel Dynamic Bayesian Network-Based Networked Process Monitoring Approach for Fault Detection , Propagation Identification , and Root Cause Diagnosis. *AIChE J*. doi: 10.1002/aic

Yuan Z, Khakzad N, Khan F, Amyotte P (2016) Domino effect analysis of dust explosions using Bayesian networks. *Process Saf Environ Prot* 100:108–116. doi: 10.1016/j.psep.2016.01.005

Yuan Z, Khakzad N, Khan F, Amyotte P (2015a) Risk analysis of dust explosion scenarios using bayesian networks. *Risk Anal* 35:278–291. doi: 10.1111/risa.12283

Yuan Z, Khakzad N, Khan F, Amyotte P (2015b) Risk-based optimal safety measure allocation for dust explosions. *Saf Sci* 74:79–92. doi: 10.1016/j.ssci.2014.12.002

Yun G, Rogers WJ, Mannan MS (2009) Risk assessment of LNG importation terminals using the Bayesian-LOPA methodology. *J Loss Prev Process Ind* 22:91–96. doi: 10.1016/j.jlp.2008.10.001

Zarei E, Azadeh A, Khakzad N, Aliabadi MM, Mohammadfam I (2017) Dynamic safety assessment of natural gas stations using Bayesian network. *J Hazard Mater* 321:830–840. doi: 10.1016/j.jhazmat.2016.09.074

Zerouali B, Kara M, Hamaidi B (2016) Bayesian Network and Bow Tie to Analyze the Risk of Fire and Explosion of Pipelines. *Process Saf Prog* 25:326–330. doi: 10.1002/prs

Zerrouki H, Smadi H (2017) Bayesian Belief Network Used in the Chemical and Process Industry: A Review and Application. *J Fail Anal Prev* 17:159–165. doi: 10.1007/s11668-016-0231-x

Zerrouki H, Tamrabet A (2015) Safety and Risk Analysis of an Operational Heater Using Bayesian Network. *J Fail Anal Prev* 15:657–661. doi: 10.1007/s11668-015-9986-8

Zhang J, Teixeira AP, Guedes Soares C, Yan X, Liu K (2016) Maritime Transportation Risk Assessment of Tianjin Port with Bayesian Belief Networks. *Risk Anal* 36:1171–1187. doi: 10.1111/risa.12519

Zhao L, Wang X, Qian Y (2012) Analysis of factors that influence hazardous material transportation accidents based on Bayesian networks: A case study in China. *Saf Sci* 50:1049–1055. doi: 10.1016/j.ssci.2011.12.003

Chapter 3

RELIABILITY AND SAFETY ANALYSIS USING FAULT TREE AND BAYESIAN NETWORKS

3.1 Introduction

The safety of all technical systems is a basic requirement. During the last few years, researchers have developed many techniques for handling the problems of system safety and risk analysis (Singer 1990) including Hazard and operability analysis (HAZOP), Fault Tree Analysis (FTA), Event Tree Analysis (ETA) and Failure mode effect analysis (FMEA) (Khan and Abbasi 1998). All of these techniques share a common objective, which is to reduce the catastrophic risk to an acceptable or tolerable level (Ferdous et al. 2012).

The fault tree is a very popular technique that is used extensively in reliability and risk analysis of process systems (Goodman 1988) (Ruijters and Stoelinga 2015) (Singer 1990). The technique based on defining the Top Event (TE), which represent the undesired event, and then graphically constructing the tree using logical gates until reaching the possible events that cause the TE. Nevertheless, FT is not suitable for modeling complex and large system with redundant failures multi-state components, and dependent between events. Many authors used Dynamic Fault Tree (Čepin and Mavko 2002), Monte Carlo Simulation (Durga Rao et al. 2009), and fuzzy set theory (Suresh et al. 1996; Singer 1990; Markowski et al. 2009) to deal with the dynamic behaviour of system failure mechanisms and the uncertainties in the failure probability of system components or basic events. Recently, some authors used Bayesian network to overcome the limitations of Fault Tree

(Bobbio et al. 2001) (Khakzad et al. 2011).

Bayesian networks (BNs) are directed acyclic graphs (DAG) that belong to the family of probabilistic graphical models (GMs). In this method, the nodes represent variables; the arcs indicate the relationships between these variables and a conditional probability table (CPT) quantified the strength of these dependencies (Torres-Toledano and Sucar 1998). Weber et al. (2012) presented an exhaustive review of BN application in diverse areas. BN are used particularly in reliability analysis (Langseth and Portinale 2007), to deal with uncertainty in the complex system (Simon et al. 2007) and fault diagnosis (Huang et al. 2008), also to model safety instrumented systems (SIS)(Kannan 2007). Bobbio et al.(2001) used BN to solve some problems of FT such as multi-state components and dependent failures. In addition, Common cause failures (CCF) in BN is easily to model since the probabilistic dependence is included in the CPT, while in FT an OR gate must be added, in which the first input is the system failure, and the other represent CCF. Most recently, Khakzad et al. (2011) compares the two approaches in the safety analysis of process systems. The main objective of the present work is to discuss some features of BN and show the ability of BN in deferent modeling steps particularly in multi-state variables and dependent failures. Furthermore, it shows the suitability of BN to discover the most critical components due to its ability to update probabilities.

This chapter is organized as follows: The description of the two methods of Fault tree and Bayesian networks, and the mapping algorithm is first presented in section 1. A simple accident scenario of steam boiler system and the comparison of both FT and BN are given in Section 2 with some features of BN. The application of the sequential learning is presented in section 3. The conclusion of this chapter is presented in the last section.

3.2 Analysis Approach

Two techniques are discussed in this section, Fault Tree Analysis (FTA) and Bayesian Networks technique (BNs). Also, the mapping algorithm from FT to BN is presented.

3.2.1 Fault Tree Analysis

Fault tree analysis is a common technique used in deferent areas and particularly in reliability assessment (Vaurio 2002). FTA is an analytical tool that proceeds deductively from the occurrence of an unwanted event (Top Event) to the identification of the root

causes of that event (Basic events) and identifies the weak links in the system (Khan and Abbasi 1998; Nouri.Gharahasanlou et al. 2014). The technique is widely used for both qualitative and quantitative assessment. The results of the qualitative phase are the Minimal Cut Sets (MCS), they represent the system logic function as Boolean algebra to identify the combination of basic events in component failure modes, an MCS is a combination of basic events that cause the undesired event. In the quantitative phase, all the basic components are assigned a probabilistic value for their occurrence and calculated the value of the top event (Ramesh and Saravannan 2011). The logic gates connect all the events in FT, which essentially are; AND gate, both of the basic events have to occur for the top event to occur, and OR gate, one of the basic events have to occur for the top event to occur (Goodman 1988). The AND gate is the intersection of the sets containing all input events; its probability can calculate by equation 3.1:

$$P = \prod_{i=1}^n P_i \quad (3.1)$$

The output of an OR gate occurs if one of the input events occurs and its probability obtained by equation 3.2:

$$P = 1 - \prod_{i=1}^n (1 - P_i) \quad (3.2)$$

A fault tree provides valuable information about possible combinations of basic events that can lead to the top event. This combination is called a cut set and is defined as a set of basic events whose occurrence ensures that the top event occurs. The most interesting in the cut sets are the minimum one. A minimum cut set is the set cannot be reduced without losing its status as a cut set (Rausand 2011).

3.2.2 Bayesian Network technique

Bayesian networks or Bayesian belief networks are one of the probabilistic methods for reasoning under uncertainty. It is have been successfully applied in a wide range of domains such as safety and reliability domains (Langseth and Portinale 2007). BN is a graphical model that permits a probabilistic relationship among a set of variables. Each node represents a variable, and the arcs indicate direct probabilistic relations between the connected nodes (Weber and Jouffe 2006) as shown Figure 3.1, the arcs are directed from the parent node (A, B) to the child node (C). Each node in the BN has a conditional probability table (CPT) illustrate the relation cause- effect between nodes. Bayesian networks are used to calculate the new probabilities when a new information appear

based on the d-separation and the chain rule (Jensen and Nielsen 2007). BNs are based on two equations that are mentioned in the previous chapter (equation 2.1 and equation 2.2)

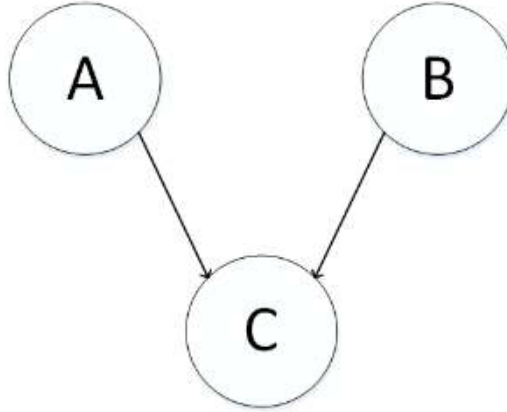

Figure 3.1: Example of BN model

Bayesian networks have proven their efficiency in many real word applications and particularly in the reliability analysis due to their ability to represent the variables of systems in qualitative and quantitative manner. Over the last two decades, many authors discuss the advantages of BNs in reliability analysis over some traditional frameworks such as reliability block diagrams and fault trees. Bobbio et al. (2001) show the suitability of BN over FT in dependability analysis of safety critical systems also; (Langseth and Portinale 2007) discuss the properties of the modeling framework that make BNs suitable for reliability applications. Furthermore, Khakzad et al. (2011) compare both FT and BN in safety analysis of process facilities.

To understand the circulation of the information in the BN, we will give a calculus example in the following;

Let us consider the example in Figure 3.2, in the example below the conditional probability of variable A given variable B, can be calculated as:

$$P(A/B) = \frac{P(B|A)P(A)}{P(B)} = \frac{P(B, A)}{\sum_A(B, A)} \quad (3.3)$$

Table 3.1: Unconditional probability table of variable A

A	a_1	0.3
	a_2	0.7

Table 3.2: Conditional probability table of variable B

	A	a_1	a_2
B	b_1	0.6	0.2
	b_2	0.4	0.8

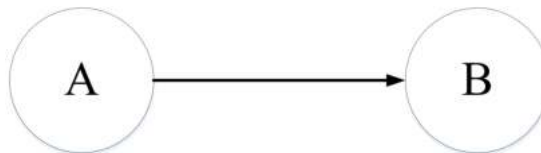

Figure 3.2: Example of BN

For illustrative purpose, we propose that the variable B is in the state b_1 , then, given this knowledge, we will update the probability of the variable A being in the state a_2 , using equation 3.3 as:

$$\begin{aligned}
 P(A = a_2|B = b_1) &= \frac{P(B = b_1|A = a_2)P(A = a_2)}{P(B = b_1)} \\
 &= \frac{P(B = b_1|A = a_2)P(A = a_2)}{P(B = b_1|A = a_2)P(A = a_2) + P(B = b_1|A = a_1)P(A = a_1)} \quad (3.4)
 \end{aligned}$$

We use the conditional probabilities from Table 3.1 and Table 3.2, and insert these probabilities into equation 3.4 as the following way:

$$P(A = a_1|B = b_1) = \frac{0.2 \times 0.7}{0.2 \times 0.7 + 0.6 \times 0.3} = 0.4375 \quad (3.5)$$

In Figure 3.3, we show how to make the application above in Hugin Lite software.

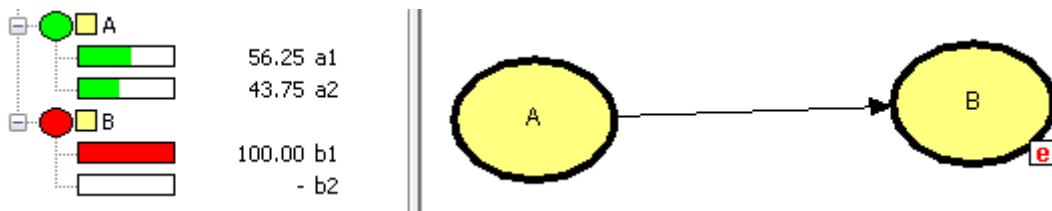

Figure 3.3: Evidence $B = b_1$ inserted in the BN

3.2.3 Mapping FT into BN

Any FT has a corresponding BN basing on the work of Bobbio et al. (2001). The basic events in the FT are considered as the root nodes in the BN, the intermediate events in FT are the intermediate nodes while the top event is the leaf node (child) in the BN, and each node has their particular CPT. For further explanation, let A, B, and C be random variables with two states; 1 if the event occurs and 0 if the event does not occur. Figure 3.4 shows the fault tree for AND-gate and the corresponding Bayesian network with the conditional probability table (Table 3.3), the fault tree for OR-gate and the corresponding Bayesian network are shown if Figure 3.5 with the conditional probability table (Table 3.4). The probability of the top event in CPT is calculated using equation 3.1 and equation 3.2 for AND- gate and OR-gate, respectively.

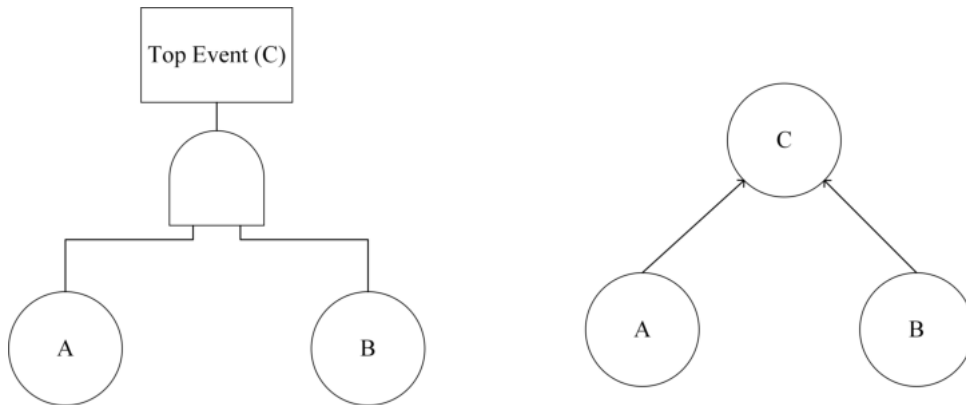

Figure 3.4: The representation of AND-gate in FT and BN

Table 3.3: Conditional probability table corresponding to AND-gate

Parents		Top event (C), Pr (C=1)
A	B	
0	0	0
0	1	0
1	0	0
1	1	1

Figure 3.5: The representation of OR-gate in FT and BN

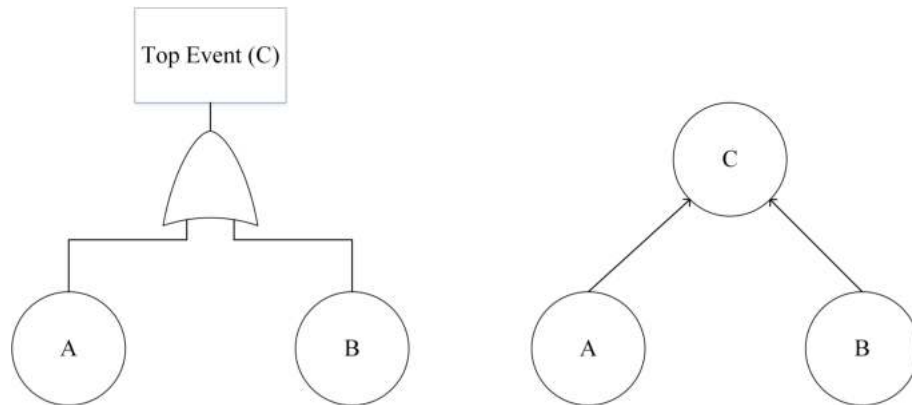

Table 3.4: My caption

Parents		Top event (C),
A	B	Pr (C=1)
0	0	0
0	1	1
1	0	1
1	1	1

3.3 Safety Analysis of Steam Boiler System (SBS)

3.3.1 Description of the steam boiler system

Figure 3.6 shows the sketch of the considered steam boiler system (SBS) which was earlier reported by Marvin Rausand (2003). It was designed to supply steam at a specified pressure. Water is led to the boiler through a pipeline with a regulator valve, a Level Indicator Controller Valve (LICV). Fuel is led to the burner chamber through the pipeline with a regulator valve, a Pressure Controller Valve PCV. The latter is installed in parallel with a bypass valve V-1 together with two isolation valves to facilitate inspection and maintenance of the PCV during normal operation. V-1 must be shut off after maintenance has been completed.

The level of the water in the boiler is surveyed by a level emitter (LE). The water level is maintained in an interval between a specified low level and a specified high level by a pneumatic control circuit connected to the water regulator valve LICV. The level

indicator controller (LIC) translates the pneumatic “signal” controlling the valve LICV.

It is very important that the water level does not come below the specified low level. When it does, a pneumatic “signal” is passed from the level indicator controller LIC to the transmitter (LT). The LT translates the pneumatic “signal” to an electrical “signal” which is sent to the solenoid valve (SV). The solenoid valve again controls the valve PCV on the fuel inlet pipeline. This circuit is thus installed to cut off the fuel supply in case the water level comes below the specified low level.

The pressure in the boiler and the steam outlet pipeline is surveyed by a pressure controller PC which is connected to the solenoid valve SV, and thereby to the valve PCV on the fuel inlet pipeline. This circuit is thus installed to cut off the fuel supply in case the pressure in the boiler increase above a specified high pressure. The numerical data for the quantitative treatment of this example are given in Table 3.5.

It is assumed that all the components of the steam boiler are non-repairable items, the items are assumed to have a constant failure rate λ_i (the number of failures per year of item i) and is put into operation at time $t=0$. The probability of failure of the basic event E_i at time t is then

$$Pr(E_i(t)) = 1 - e^{-\lambda_i t} \tag{3.6}$$

where Pr denotes the probability of failure, λ_i represents the failure rate, and t is the time inspection interval.

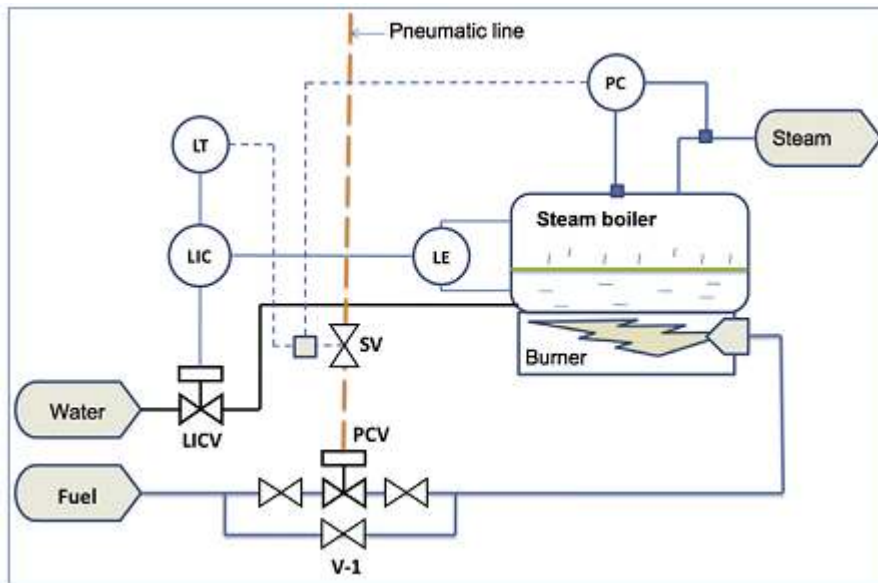

Figure 3.6: Steam Boiler Schematic (Innal et al. 2014)

Table 3.5: Different events related to an accident scenario in the steam boiler system and their occurrence probabilities.

Number	Component	Symbol	Failure rates/h	Probability of failure at t=8760h
1	level emitter	LE	1.30E-06	0.0113
2	level indicator controller	LIC	5.00E-06	0.0428
3	Level Indicator Controller Valve	LICV	2.70E-06	0.0233
4	level transmitter	LT	6.00E-07	0.0052
5	Solenoid valve	SV	9.00E-07	0.0078
6	Pressure Controller Valve	PCV	2.00E-06	0.0173
7	Pressure controller	PC	1.60E-06	0.0139

3.3.2 Fault tree analysis

Figure 3.7 shows the FT of the steam boiler system; the FT is constructed based on the work of Innal et al. (2014). The probability of the top event is calculated as 0.0026303. To make a good explanation of the accident, it is necessary to determine the critical primary events, and the minimal cut-sets leading to the top event occurrence, the minimal cut-sets is calculated using the specific software GRIF-Workshop (2011). The intermediate events: fail 1, fail 2 and fail 3 represent the layer of protection: Water regulation system for fail 1, Shut of fuel supply to the burner for fail 2 and fail 3.

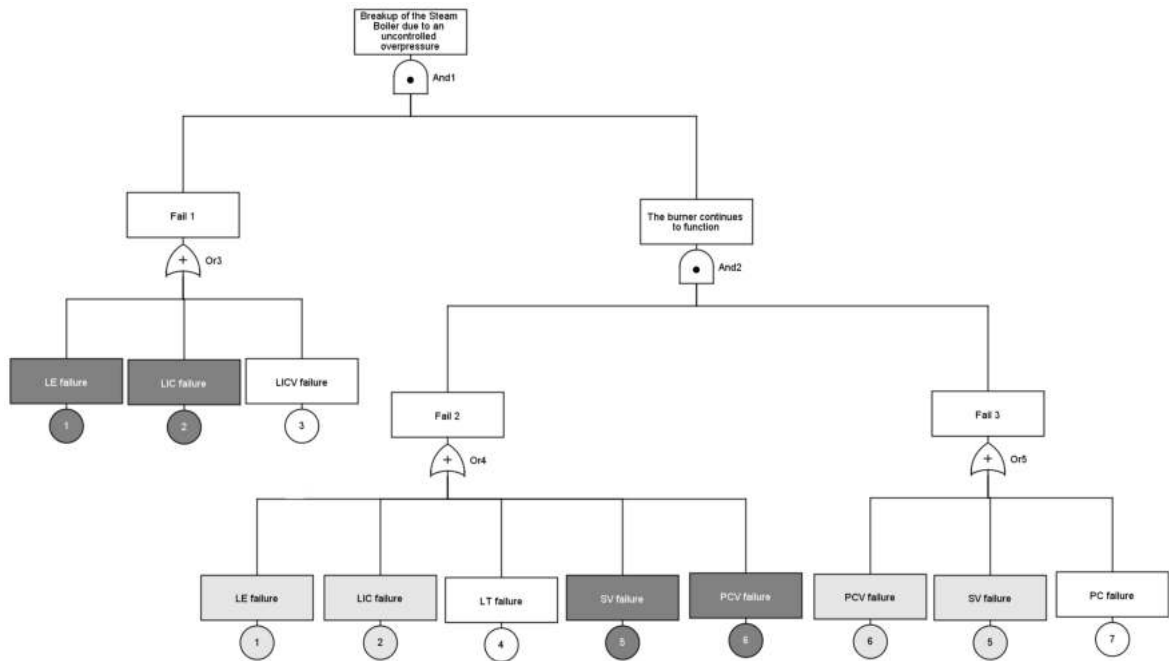

Figure 3.7: FT for the Steam Boiler System (Innal et al. 2014)

The importance of each component is estimated by making that event absent and repeating the fault tree analysis, and all the values are transformed into improvement index as shown in Table 3.6. This index signifies percent contribution of each event in leading to the top event and the highest one need immediate care (Khan et al. 2002). For example, the improvement factor of C1 = the probability of the tree (0.0026303) – the probability of the tree without C1 (0.00221).

As we can notice from Table 3.6: the LIC (level indicator controller), PCV (Pressure Controller Valve) and PC (Pressure controller) have the highest improvement index, so these components considered first to improve the safety of the system.

Table 3.7 shows minimal cut sets (MCS) and their importance (IM) of the steam boiler system, each minimal cut-set signify the shortest paths leading to the accident. The rank or probability of each MCS is calculated by the intersection of each primary event interfere in MCS. Also, the most important minimal cut-set is M=C2.C6 with probability of 7.442E-4 and IM= 2.83E-01, proving that the intersection of Level Indicator Controller (LIC) and Pressure Controller Valve (PCV) are the likely components that lead to system failure (see Appendix A.3, for more detail about the calculation of each IM).

Table 3.6: Events probabilities and improvement factors and improvement index for FT analysis

Event not occurring	Probability $P(S \setminus C_i = False)$	Improvement factors	improvement index
0	0.0026303	0.00	0.00
C1	0.00221	0.00042	8.096706
C2	0.0010186	0.001612	31.04797
C3	0.0020741	0.000556	10.7147
C4	0.0026287	1.6E-06	0.030823
C5	0.0020514	0.000579	11.15199
C6	0.0013371	0.001293	24.91235
C7	0.0019012	0.000729	14.04546

Table 3.7: Minimal cut sets and their importance

Order	Coupe	Probability	IMi
2	C5,C1	8.89E-05	3.38E-02
2	C2,C5	3.36E-04	1.28E-01
2	C3,C5	1.84E-04	6.98E-02
2	C6, C1	1.97E-04	7.48E-02
2	C2,C6	7.44E-04	2.83E-01
2	C3,C6	4.06E-04	1.54E-01
2	C7, C1	1.57E-04	5.98E-02
2	C2,C7	5.96E-04	2.26E-01
3	C3,C4,C7	1.70E-06	6.47E-04

3.3.3 Bayesian Network Analysis

There are several commercial and research tools designed for BN, the most popular of these tools are BayesiaLab, Hugin, and Netica. In this chapter Hugin software (2015) is used due to its advantages not only serves as “drag and drop” style model construction tool (see Figure 3.8), but also provides libraries of routines for computation of probabilities as well as learning algorithms, facilitating the easy design and authoring of BN models for diagnostics (see Appendix A.1). Also, it is possible to view the status of any given

number of observations, and “run” to obtain posterior probability (Ren et al. 2009). FT diagram shown in Figure 3.7 were transformed into a BN (Figure 3.9) using the mapping algorithm described in Section 2. Based on an algorithm provided in Hugin, 12 nodes (11 root nodes and one leaf nodes) and 15 edges are generated. The CPTs for all of the arcs in the comprehensive BN were calculated based on the logic gates (AND/OR gates) defined in FT.

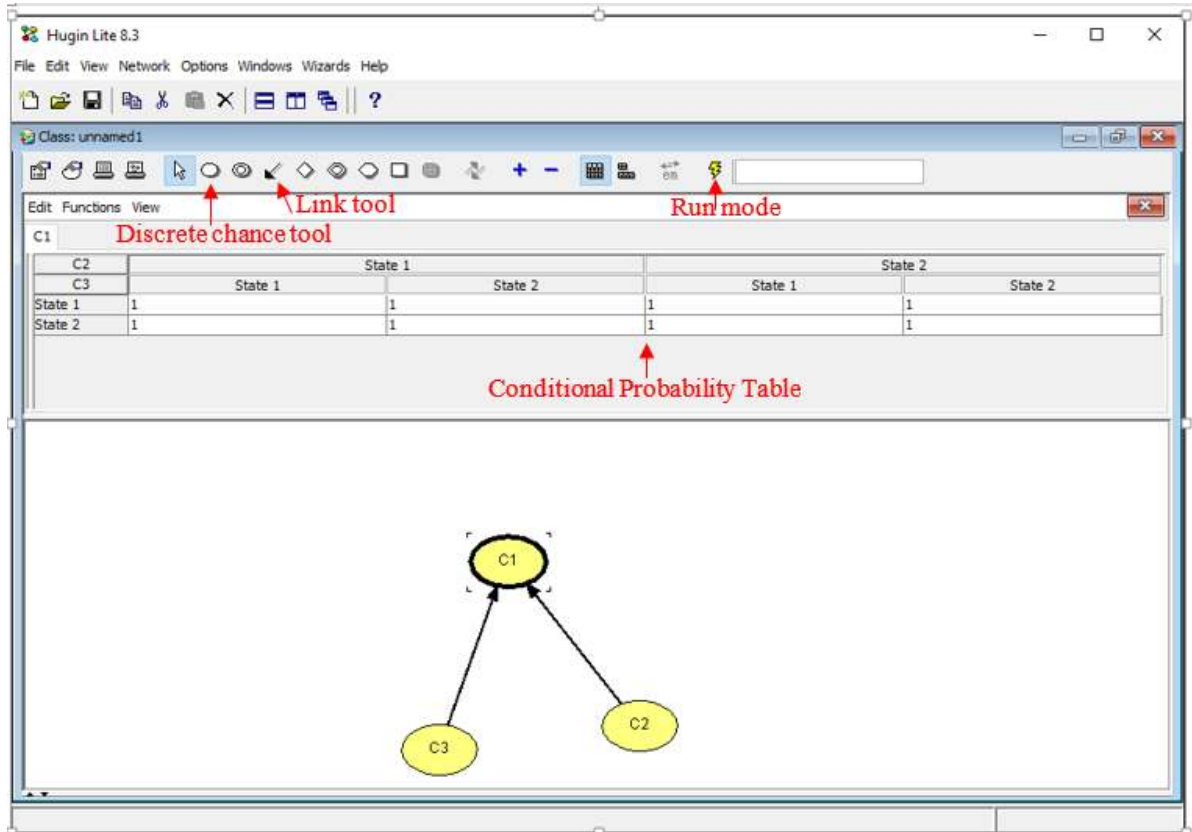

Figure 3.8: Example from Hugin software

The prior probability of the leaf node in the BN is calculated to be 0.0026, which is the same as FT analysis. As can notice from Table 3.8, the results of the improvement index are also the same as FT analysis.

A BN can be used to perform both predictive (forward) and diagnostic (backward) analysis. In the latter, the posterior marginal probability distribution of each component are calculated to determine the critical components of the system as shown in Figure 3.10. However, the predictive analysis is based on the prior probabilities of the root nodes and the conditional dependence of the leaf node (Bobbio et al. 2001). The prior and the posterior probabilities of the components of the system are well depicted in Table 3.9. The posterior probabilities are calculated considering the breakup of the SBS

($Pr(\text{Breakup of the SBS}) = 1$). The most critical components of the system are the primary events *level indicator controller (C2)* and *Pressure Controller Valve (C6)* with probability 0.6294 and 0.5005, respectively as shown in Figure 3.10 and Table 3.9.

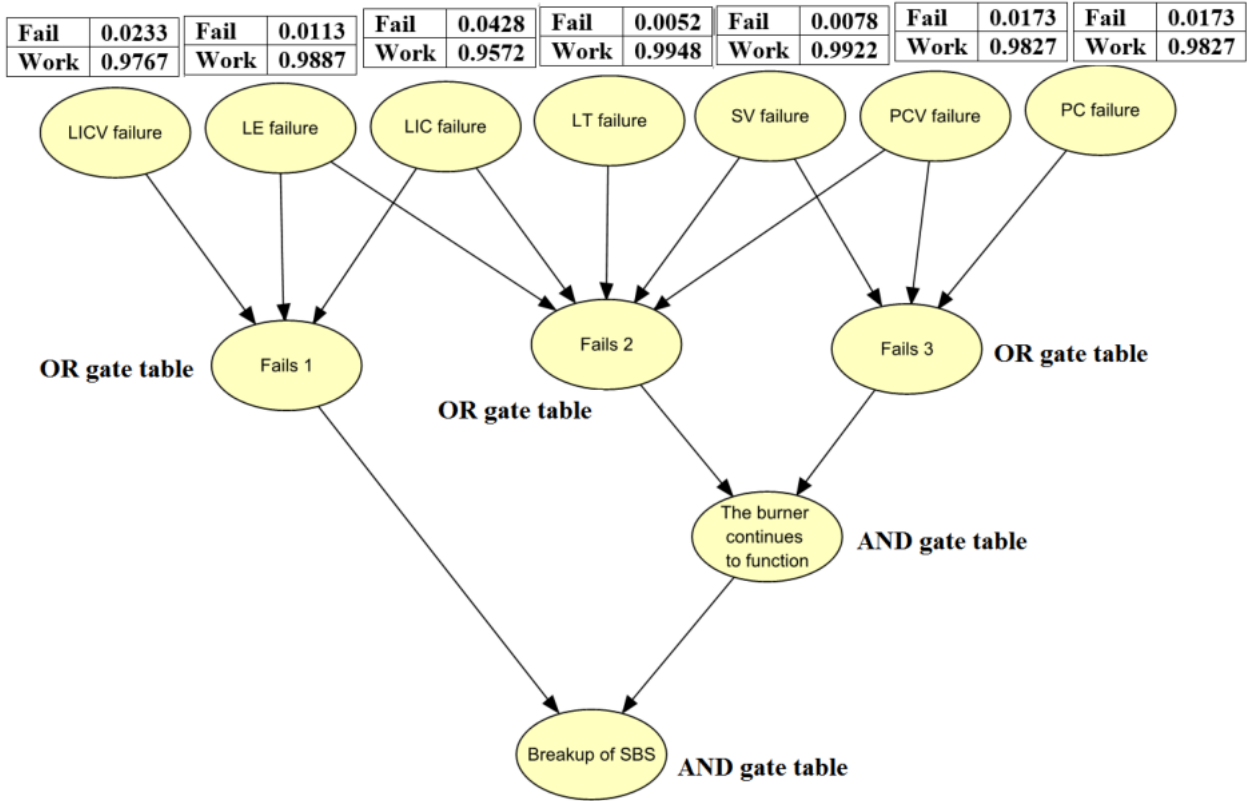

Figure 3.9: BN for the Steam Boiler System

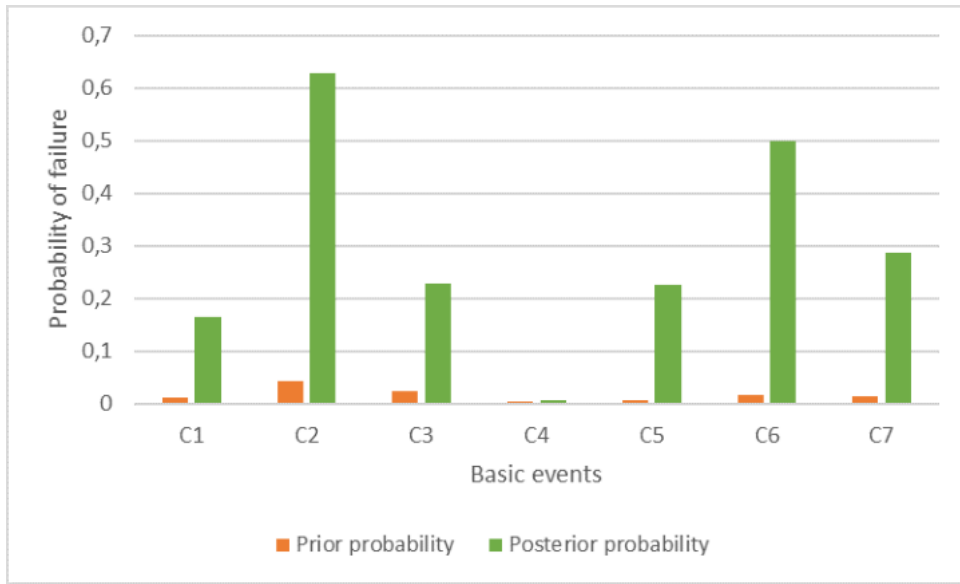

Figure 3.10: Prior and posterior probabilities the basic events

The most probable configuration or most probable explanation (MPE) in BN represent the most probable state of all the variables given the accident occurrence. The MPE helps identify weak links and provide a good understanding for the safety analysis of the system more than the minimal cut-sets (Khakzad et al. 2011), because this latter does not provide any information about the occurrence or non-occurrence of the primary events not included in it (Bobbio et al. 2001). The most probable state given the accident occurrence is the one corresponding to the occurrence of the primary events C2 and C6 and the non-occurrence of the other primary events with probability:

$$P(\bar{C}_1, C_2, \bar{C}_3, \bar{C}_4, \bar{C}_5, C_6, \bar{C}_7 / \text{breakup of the SBS}) = 0.27 \quad (3.7)$$

It can be noticed from the probability above that the MPE and the posterior probability (Table 3.7) gave precise results compared with the improvement index from Table 3.8. In the same table, we observe that the improvement index of C2 and C6 are 31.09 and 24.97, respectively which are the highest values, the improvement index is calculated using the same way as in FT.

Table 3.8: Events probabilities and improvement factors and improvement index for BN analysis

Event not occurring	Probability $P(S \setminus C_i = False)$	Improvement factors	Improvement index
0	0.00263	0.00	0.00
C1	0.00222	0.00041	7.919645
C2	0.00102	0.00161	31.09909
C3	0.0020743	0.000556	10.73402
C4	0.002629	1E-06	0.019316
C5	0.0020515	0.000579	11.17443
C6	0.0013372	0.001293	24.97199
C7	0.0019013	0.000729	14.07572

Other features of BN will be discussed in this section, which are the dependent failures and multi-state variables. To show the efficiency of these features and reduce the likelihood of the incident, PCV valve is considered as a manual valve that needs a operator to be controlled with two states: Work and Fail. An Alarm helps to inform the operator in case of failure which leads to close the valve by the operator as shown in Figure 3.11, the Alarm have three states: fail-to-danger (alarm fails to launch a voice when PCV fails) , fail-to-safe (alarm launches a voice although PCV works) and work (alarm launches a voice when PCV fails) (Table 3.10).

Table 3.9 shows the prior and posterior probabilities of the modified BN (with alarm and operator), the LIC have the highest posterior probability. Furthermore, the Alarm and the operator added help to decrease the posterior probability of *Pressure Controller Valve* (PCV) from 0.5 to 0.0636. The most probable configuration of the basic events causes the accident is calculated to be the occurrence of the components; *level indicator controller* (C2), *Pressure controller* (C7), and *operator* (C8), and non-occurrence of the rest, with a probability of

$$P(\bar{C}_1, C_2, \bar{C}_3, \bar{C}_4, \bar{C}_5, \bar{C}_6, C_7, C_8, \bar{C}_9 / \text{breakup of the SBS}) = 0.4 \quad (3.8)$$

As we can see by adding an Alarm system and operator, the probability of the breakup of the steam boiler system decrease from 0.00263 to 0.0013 as shown in Table 3.9 and Figure 3.12 , which helps to improve the safety of the system.

In addition, we can provide more information from the Most Probable Configuration about the critical components leading to the accident (Kabir et al. 2015). The MPE

Table 3.9: Different modeling steps in Bayesian Networks analysis

<i>Component</i>	<i>First modeling</i>		<i>Alarm/operator modeling</i>	
	Prior	Posterior	prior	posterior
Breakup of the SBS	0.0026	1	0.0013	1
LE	0.0113	0.1663	0.0113	0.1817
LIC	0.0428	0.6294	0.0428	0.6878
LICV	0.0233	0.2299	0.0233	0.1585
LT	0.0052	0.0058	0.0052	0.0064
SV	0.0078	0.2262	0.0078	0.4252
PCV	0.0173	0.5005	0.0173	0.0454
PC	0.0139	0.2872	0.0139	0.5363
Operator (C8) (Work)			0.9448	1
Alarm (C9); fail-to-danger			0.0451	0
fail-to-safe			0.0012	0.0636
work			0.9537	0.9364

indicate that the operator can be a critical supplementary event causing the accident, so more attention should be given to this primary event.

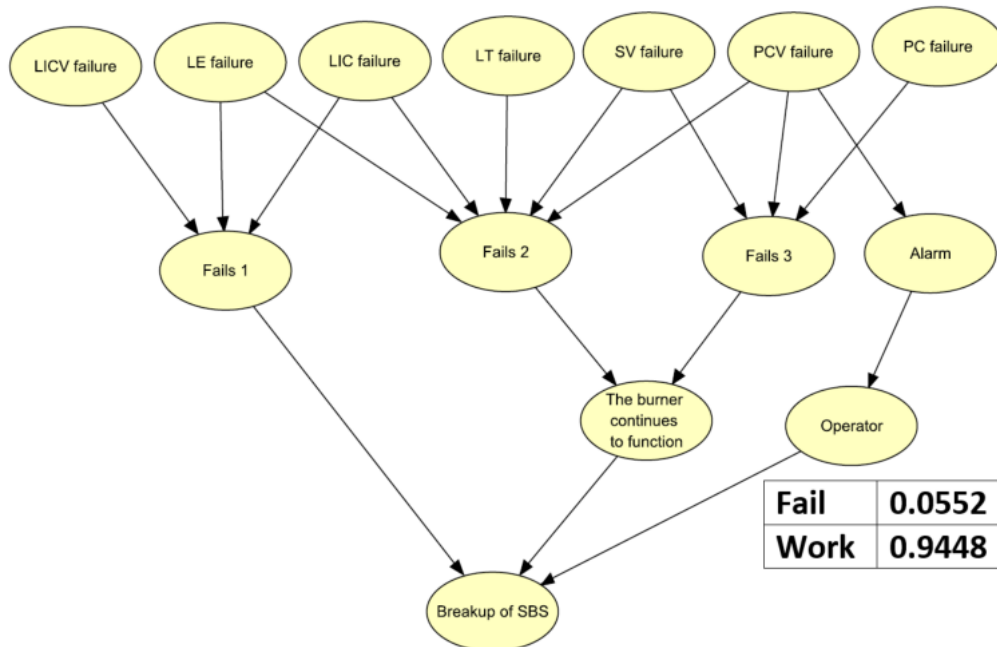

Figure 3.11: BN with an Alarm and operator

Table 3.10: CPT of Alarm

PCV failure	FALSE	TRUE
Fail-to-danger	0.03	0.93
Fail-to-safe	0.00	0.07
Work	0.97	0.00

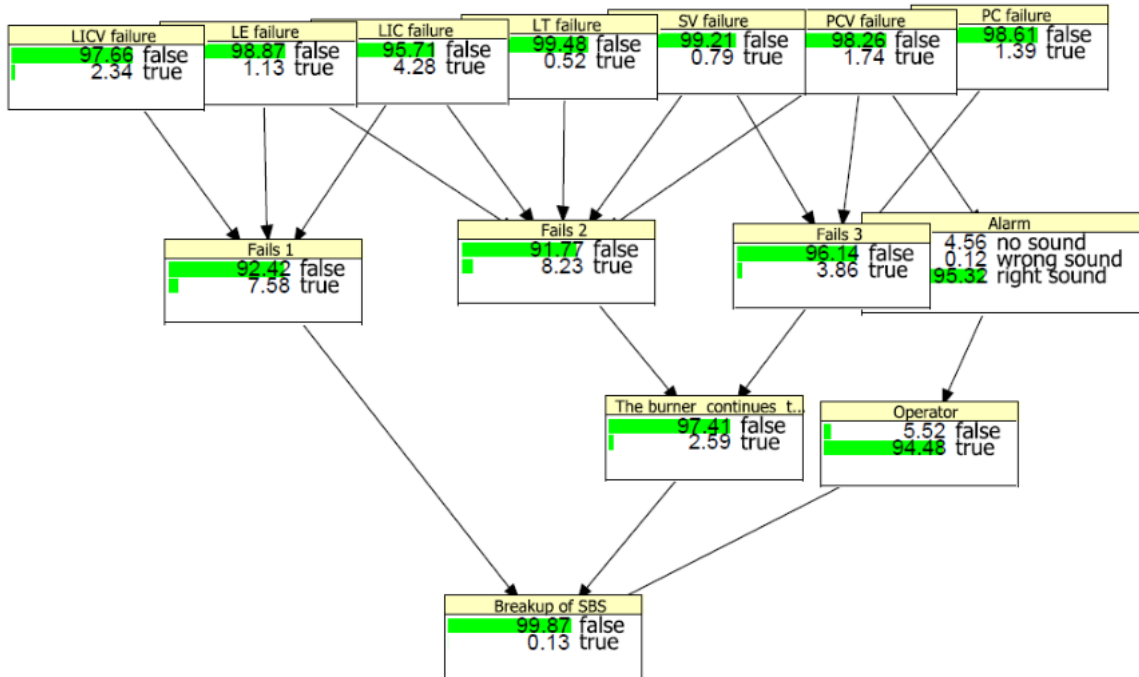

Figure 3.12: BN with CPTs

3.3.4 Sequential learning

Sequential learning, also known as probability adapting is used particularly to model dynamic systems (Khakzad et al. 2013b) by calculating the posterior probability of any event x_i in the BN model given that other event M has been occurred n times (Khakzad et al. 2013a). In the probability adapting, the prior experience adopted from information collected during a time interval (in our example 5 years) to revise the probability distributions of the nodes. For illustrative purposes, we will use the prior experience obtained during 5 years for the occurrence of the accident scenario in the SBS as shows Table 3.11. All the nodes in the BN model are updated unless they are d-separated from the observed nodes. For example, updated probabilities using information in the fifth year are estimated using probabilities in the form of $P(x_i(\text{accident} = 3\text{breakup of the SBS}))$.

Table 3.11: Accident occurrence during 5 years of SBS function.

Years	2005	2006	2007	2008	2009	2010
Occurrence of TE	0	1	1	2	3	5
LE	0.0113	0.1817	0.1817	0.2127	0.2487	0.3089
LIC	0.0428	0.6878	0.6878	0.8052	0.8573	0.9064
LICV	0.0233	0.1585	0.1585	0.1464	0.1583	0.1808
LT	0.0052	0.0064	0.0064	0.0061	0.0061	0.0062
SV	0.0078	0.4252	0.4252	0.5259	0.6018	0.7043
PCV	0.0173	0.0454	0.0454	0.0099	0.0035	0.001
PC	0.0139	0.5363	0.5363	0.6105	0.6711	0.7508
Alarm	0.9537	0.9364	0.9364	0.9901	0.9965	0.9989
Operator	0.9448	1	1	1	1	1

As one can see from Figure 3.13 , the probabilities of LIC, PC and SV have increased more than the other events, compared to their initial estimates in the first year. Also, we can notice that the probabilities of the Alarm and the operator remain constant or increase, and have the highest value compare with the other components, that means that the failure of the alarm and the operator increase the accident occurrence.

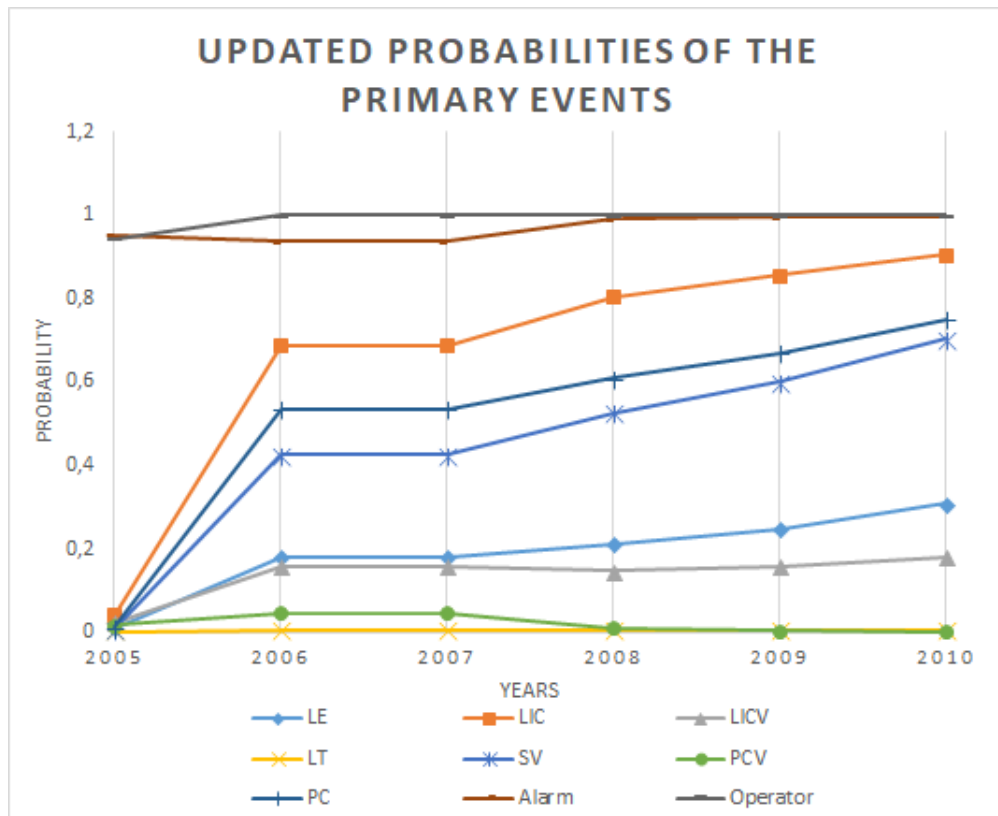

Figure 3.13: Updated probabilities of the Basic event during 5 years of SBS function.

3.3.5 Conclusion

In this chapter, we presented two methods that are used extensively in the field of safety analysis. In the beginning, we explained how to map an FT to BN and discuss the features of the two methods that help to compare them, and we can notice that similar results are obtained. To improve the safety of the system we propose to add an alarm with an operator in our system to decrease the occurrence probability of the accident. BN have proved its ability in multi-state variables modeling (alarm with three states) and dependent failures modeling (alarm/operator) which help to overcome some limitations of FT.

Bayesian networks present a robust method for modeling the complex system in the probability and uncertainty analysis and become more suitable and flexible than the FTA. Moreover, Bayesian networks can be used to update probabilities dynamically; it is a powerful method for updating in the light of new information. This latter known as posterior probabilities used to predict the occurrence frequency of the critical components. Also, the most probable explanation (MPE) in BN is much more helpful than the minimal cut-set and give information about the occurrence or non-occurrence of all the events.

An important advantage of BN is the sequential learning or probability adapting, which used to conduct a dynamic revision of the prior probability of accident components; the number of an accident during a time interval is used as evidence to dynamically assess the system's safety and to predict the probability of the components.

In the following chapter, we will apply the coupled method of BT and BN to provide a quantitative risk analysis, then construct an OOBN for a Liquefied Natural Gas (LNG) tank.

The content of this chapter is published in (Zerrouki and Smadi 2017), (Zerrouki and Tamrabet 2015a), and (Zerrouki and Tamrabet 2015b).

References

Bobbio A, Portinale L, Minichino M, Ciancamerla E (2001) Improving the analysis of dependable systems by mapping Fault Trees into Bayesian Networks. *Reliab Eng Syst Saf* 71:249–260.

Čepin M, Mavko B (2002) A dynamic fault tree. *Reliab Eng Syst Saf* 75:83–91.

Durga Rao K, Gopika V, Sanyasi Rao VVS, Kushwaha HS, Verma AK, Srividya A (2009) Dynamic fault tree analysis using Monte Carlo simulation in probabilistic safety assessment. *Reliab Eng Syst Saf* 94:872–883.

Ferdous R, Khan F, Sadiq R, Amyotte P, Veitch B (2012) Handling and updating uncertain information in bow-tie analysis. *J Loss Prev Process Ind* 25:8–19.

Finn V. Jensen and Thomas D. Nielsen (2007) *Bayesian Networks and Decision Graphs*, second edi. Springer, New York

Goodman GVR (1988) An assessment of coal mine escapeway reliability using fault tree analysis. *Min Sci Technol* 7:205–215.

GRIF-Workshop (2011) GRaphical interface for reliability forecasting software.

Huang Y, McMurrin R, Dhadyalla G, Peter Jones R (2008) Probability based vehicle fault diagnosis: Bayesian network method. *J Intell Manuf* 19:301–311.

HUGIN (2015) HUGIN Expert software version 8.1. <http://www.hugin.com>.

Innal F, Cacheux PJ, Collas S, Dutuit Y, Folleau C, Signoret JP, Thomas P (2014) Probability and frequency calculations related to protection layers revisited. *J Loss Prev Process Ind* 31:56–69.

Kabir G, Sadiq R, Tesfamariam S (2015) A fuzzy Bayesian belief network for safety assessment of oil and gas pipelines. *Struct Infrastruct Eng* 1–16.

Kannan PR (2007) Bayesian networks: Application in safety instrumentation and risk reduction. *ISA Trans* 46:255–259.

Khakzad N, Khan F, Amyotte P (2011) Safety analysis in process facilities: Comparison of fault tree and Bayesian network approaches. *Reliab Eng Syst Saf* 96:925–932.

Khakzad N, Khan F, Amyotte P (2013a) Quantitative risk analysis of offshore drilling operations: A Bayesian approach. *Saf Sci* 57:108–117.

Khakzad N, Khan F, Amyotte P (2013b) Dynamic safety analysis of process systems by mapping bow-tie into Bayesian network. *Process Saf Environ Prot* 91:46–53.

Khan FI, Abbasi S. (1998) Techniques and methodologies for risk analysis in chemical process industries. *J Loss Prev Process Ind* 11:261–277.

Khan FI, Sadiq R, Husain T (2002) Risk-based process safety assessment and control measures design for offshore process facilities. *J Hazard Mater* 94:1–36.

Langseth H, Portinale L (2007) Bayesian networks in reliability. *Reliab Eng Syst Saf* 92:92–108.

Markowski AS, Mannan MS, Bigoszezewska A (2009) Fuzzy logic for process safety analysis. *J Loss Prev Process Ind* 22:695–702.

Marvin Rausand AH (2003) *System Reliability Theory: Models, Statistical Methods, and Applications*, Second Edi. John Wiley & Sons

Nouri.Gharahasanlou A, Mokhtarei A, Khodayarei A, Ataei M (2014) Fault tree analysis of failure cause of crushing plant and mixing bed hall at Khoy cement factory in Iran. *Case Stud Eng Fail Anal* 2:33–38.

Ramesh V, Saravannan R (2011) Reliability Assessment of a Co-Generation Power Plant in a Sugar Mill Using Fault Tree Analysis. *J Fail Anal Preven* 11:56–70.

Rausand M (2011) *Risk Assessment: Theory, Methods, and Applications*. John Wiley & Sons

Ren J, Jenkinson I, Wang J, Xu DL, Yang JB (2009) An Offshore Risk Analysis Method Using Fuzzy Bayesian Network. *J Offshore Mech Arct Eng* 131:41101.

Ruijters E, Stoelinga M (2015) Fault tree analysis: A survey of the state-of-the-art in modeling, analysis and tools. *Comput Sci Rev* 15:29–62.

Simon C, Weber P, Levrat E (2007) Bayesian Networks and Evidence Theory to Model Complex Systems Reliability. *J Comput* 2:33–43.

Singer D (1990) a fuzzy set approach to fault tree and reliability analysis. *Fuzzy Sets Syst* 34:145–155.

Suresh P, Babar A, Raj V (1996) Uncertainty in fault tree analysis: A fuzzy approach. *Fuzzy Sets Syst* 83:135–141.

Torres-Toledano J, Sucar L (1998) Bayesian Networks for Reliability Analysis of Complex Systems. *Prog Artif Intell — IBERAMIA 98 SE - 17* 1484:195–206 LA–English.

Vaurio JK (2002) Treatment of General Dependencies in System Fault-Tree and Risk Analysis. *IEEE Trans Reliab* 51:278–287.

Weber P, Jouffe L (2006) Complex system reliability modelling with Dynamic Object Oriented Bayesian Networks (DOOBN). *Reliab Eng Syst Saf* 91:149–162.

Weber P, Medina-Oliva G, Simon C, Iung B (2012) Overview on Bayesian networks applications for dependability, risk analysis and maintenance areas. *Eng Appl Artif Intell* 25:671–682.

Zerrouki H, Smadi H (2017) Reliability and safety analysis using Fault Tree and Bayesian Networks. *Int J Comput Aided Eng Technol* x:1–14.

Zerrouki H, Tamrabet A (2015a) Mapping Fault Tree into Bayesian Network in safety analysis of process system. *4th Int Conf Electr Eng* 1–5.

Zerrouki H, Tamrabet A (2015b) Fault tree and Bayesian Network in safety analysis: Comparative study. In: *The 1st International Conference on Applied Automation and Industrial Diagnostics (ICAAID 2015)*. Djelfa.

Chapter 4

RISK ASSESSMENT OF A LIQUEFIED NATURAL GAS PROCESS FACILITY USING BOW-TIE AND BAYESIAN NETWORKS

4.1 Introduction

Process industries, including chemical industries, have become increasingly complex giving rise to new risks that must be controlled. To this end, risk assessment methodology has been established to identify hazards and risk elements that have the potential to cause enormous consequences, also, analyze and evaluate the risk associated with these consequences. Risk assessment is an important part from risk management, three main elements of risk management can be distinguished: risk analysis, risk evaluation and risk reduction. In risk analysis, different approaches are used to identify the risks and the consequences of accidents, fault tree analysis (FTA) and event tree analysis (ETA) have played an important role in identifying major risks and maintaining safety in process facilities. FTA is one of the classical methodologies used in risk assessment, it is a systematic safety analysis tool that proceeds deductively from the occurrence of an undesired event to the identification of the root causes of that event (Nouri.Gharahasanlou et al. 2014), while ETA represents a logic combination of various events that may follow from

an initiating event (Ferdous et al. 2009).

The bow-tie (BT) is a combined method of risk analysis that integrates fault tree and event tree to represent the risk control parameters such as causes, hazards, and consequences, on a common graph. The quantitative analysis of the bow-tie determines the likelihoods of the unwanted event as well as the consequences (Ferdous et al. 2013). This method has been widely used in risk analysis due to its ability to incorporate the causes and the consequences of an accident in one graphical model.

However, BT has some limitations, which are the limitations of both ET and FT. These are not suitable for a system with redundant failures, multi-state variables and dependent events (Khakzad et al. 2011). In addition, it is difficult for these techniques to deal with uncertainties in risk analysis unless it is combined with other techniques. Some authors used fuzzy logic (Zadeh 1973) to deal with uncertainty and imprecision in process safety analysis (Markowski et al. 2009). Several techniques have been developed such as fuzzy fault tree analysis (Mahmood et al. 2013); (Lavasani et al. 2015), fuzzy event tree analysis (Ramzali et al. 2015) and fuzzy bow-tie (Aqlan and Mustafa Ali 2014). Recently, Bayesian networks have been used in safety and risk analysis of dynamic systems (Yuan et al. 2015). A review of the used of BN in dependability, risk analysis and maintenance areas is presented in (Weber et al. 2012) and, in safety analysis of chemical and process industry (Zerrouki and Smadi 2017). Furthermore, BN used to overcome the limitations of update probabilities of different events, multi-state variables and conditional dependencies between the events in fault tree analysis (Bobbio et al. 2001); (Zerrouki and Tamrabet 2015), event tree analysis (Bearfield et al. 2005) and Bow-tie analysis (Khakzad et al. 2013a). In the latter, the authors illustrate how BNs handle the limitations of BT and show that BN can be used in dynamic safety analysis due to its probability adapting and probability updating using Bayes'theorem that helps to obtain posterior probabilities to predict the behaviour of the system when the accident occur.

Risk evaluation defined as the process where judgments are made about the acceptability of the risk generally using a comparison of the results from risk analysis with risk acceptance criteria. The main steps in risk evaluation process are to evaluate the risk against risk acceptance criteria and propose potential risk-reducing measures (Rausand 2011).

Based on the previous paragraph, the present study used the algorithm described in the work of khakzad et al.(Khakzad et al. 2013b) to map BT into BN. The latter can easily represent the dependencies between the basic events and the safety barriers and updating probabilities of the events and the consequences. The BN model is constructed

using the commercially available software AgenaRisk (AgenaRisk 2016). A diagnosis analysis is performed using BN assuming the occurrence of the top event (center node) instead of risk acceptance criteria to recognize the catastrophic consequence then the risk-reducing measures existing in the process are investigated using Bayesian networks approach. Finally, an Object-Oriented Bayesian Networks is constructed based on the previous BN model for ease of abstraction and establish an easy readable model.

This study is organized as follows; a brief description of BT and the mapping algorithm from BT into BN are presented in Section 2. Section 3 briefly describes a liquefied natural gas (LNG) processing facility used as the case study and applied the risk assessment approach, while the results are discussed in section 4. Section 5 is devoted to the conclusion.

4.2 Risk analysis methods

4.2.1 Bow-tie technique (BT)

Background of BT analysis

Before starting the study, it is necessary to describe the diagram of Bow-tie. The latter's name is derived from men's bow tie as one can see in Figure 4.1. It is a quite difficult to give a precise definition to this method because there are different types, and different goals for its application. May be the close definition is that given by Markowski et al. (2009) which describe BT model as a combined method that incorporate a fault tree (FT) and an event tree (ET) in a common diagram along with preventive and protective barriers that mitigate top events and their consequences. However, this definition does not cover all variations of the Bow-tie method. A. de Ruijter (2015) gives a review of Bow-tie method and classify it into two main types; Quantitative bowties and Qualitative bowties. Table 4.1 summarize his work and shows the variations of Bow-tie method and gives some of the latest publications of the aforementioned technique.

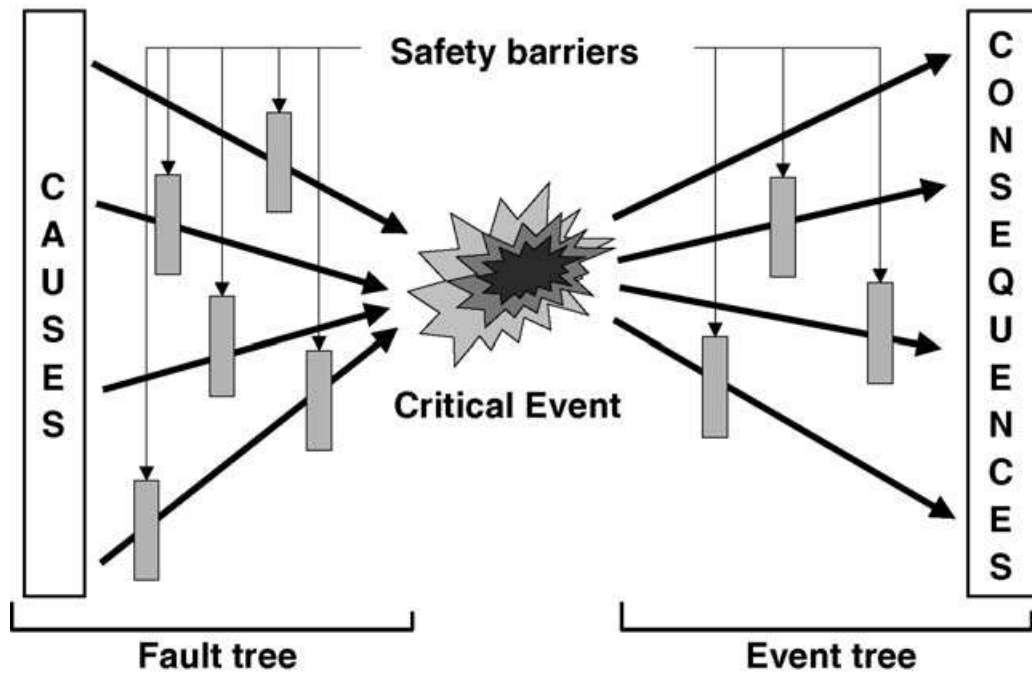
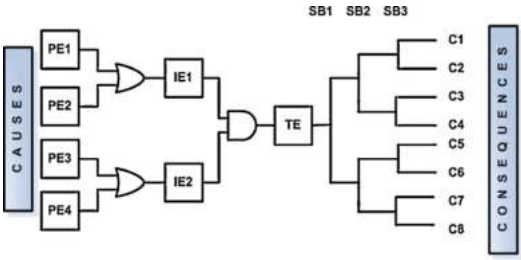



Figure 4.1: Generic example of a bowtie from de Dianous and Fiévez (2006).

BT applied for risk analysis

BTs have proven their efficiency in many real applications since it is one of the best graphical models that represent an accident scenario from their causes to the consequences. BT is composed of fault tree on the left side to identify the primary events that may cause the critical event (CE) and the right side represents the event tree that defines all possible consequences of CE as shown in Figure 4.2 (C; consequence, IE; intermediate event, BE; basic event, CE; critical event, E; event). Fault tree analysis is one of the most effective techniques for estimating the frequency of occurrence of hazardous events in probabilistic risk assessment study (Deshpande 2011). Fault trees (FT) have been used in risk analysis to represent schematically, the basic events and their various logical combinations results from the top event, generally corresponding to system failure (Barlow and Proschan 1975). While event trees (ET) is applied to analyze an initiating event (e.g. malfunctioning in the system or process). ET utilizes decision trees to graphically model the possible outcomes of an initiating event (IE) capable of producing an accidental result by a sequence of events. The occurrence probability of a specific outcome event can be obtained by multiplying the probabilities of all subsequent events existing in a path (Hong et al. 2009). The construction of the bow-tie technique follows the same basic rules as of

Table 4.1: A review of bowtie method and its classification according to Ruijter (2015).

Variations	Types	Diagrams	Some references
Combination of fault tree and event tree	Quantitative approach	 <p>(a) Generic BT model from Khakzad et al (2013)</p>	<p>(Markowski et al. 2009)</p> <p>(Khakzad et al. 2012)</p> <p>(Badreddine and Amor 2013)</p> <p>(Badreddine et al. 2014)</p> <p>(Abimbola et al. 2014)</p>
Occupational Risk Model (ORM)	Quantitative approach	 <p>(b) Bowtie representation of the Workgroup Occupational Risk Model (WORM) fundamental Functional Block Diagrams (FBD) from Aneziris et al (2008).</p>	<p>(Ale et al. 2008a)</p> <p>(Ale et al. 2008b)</p> <p>(Bellamy et al. 2007)</p> <p>(Aneziris et al. 2008)</p>
Direct cause effect relationships	Qualitative approach	 <p>(c) Generic example of a bowtie from Zuijderduijn (1999).</p>	<p>(Jacinto and Silva 2010)</p> <p>(Tucker et al. 2013)</p>

FT and ET methods. In the left side of the graph, the FTA starts by the top event through the intermediate events until reached the basics events using logic gates (AND/OR gate). While the right side of the BT corresponds to ET, which starts by the initiating event and follows the sequences of events to reach the consequences (outcome events) (Ferdous et al. 2013). BT combine the two methods to analyze an accident scenario.

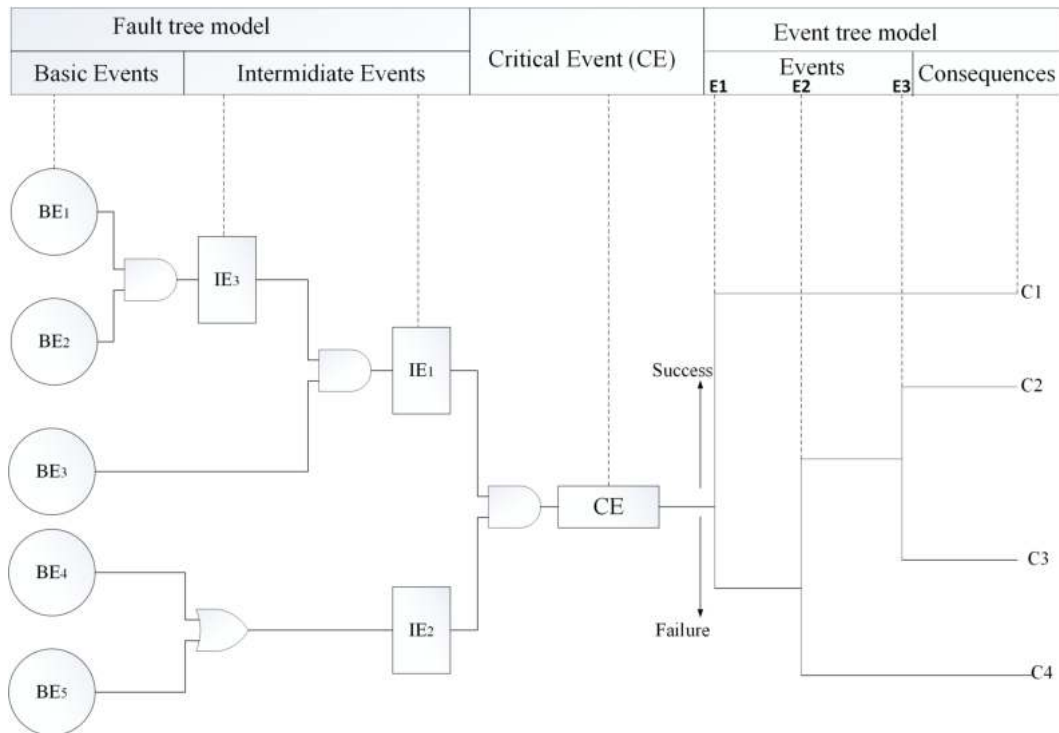

Figure 4.2: Example of bow-tie model (C; consequence, IE; intermediate event, BE; basic event, CE; critical event, E; event)

4.2.2 Mapping Bow-Tie into Bayesian Networks

Since Bow-tie (BT) is a coupled technique that is composed from fault tree (FT) and event tree (ET), it is necessary to know how to map FT and ET to BN and generate those algorithms to construct the desired BNs. Any FT has a corresponding BN based on the work of Bobbio et al. (Bobbio et al. 2001). Also, Bearfield et al. (Bearfield et al. 2005) shows how an event tree can be viewed as a Bayesian networks. Based on the aforementioned works and the mapping algorithm described in (Khakzad et al. 2013b) as shows Figure 4.3. BT model in Figure 4.2 is mapped to its corresponding BN model in Figure 4.4 (C; consequence, IE; intermediate event, BE; basic event, CE; critical event, E; event). In the present chapter each consequence represented by one node to show the

links lead to the accident.

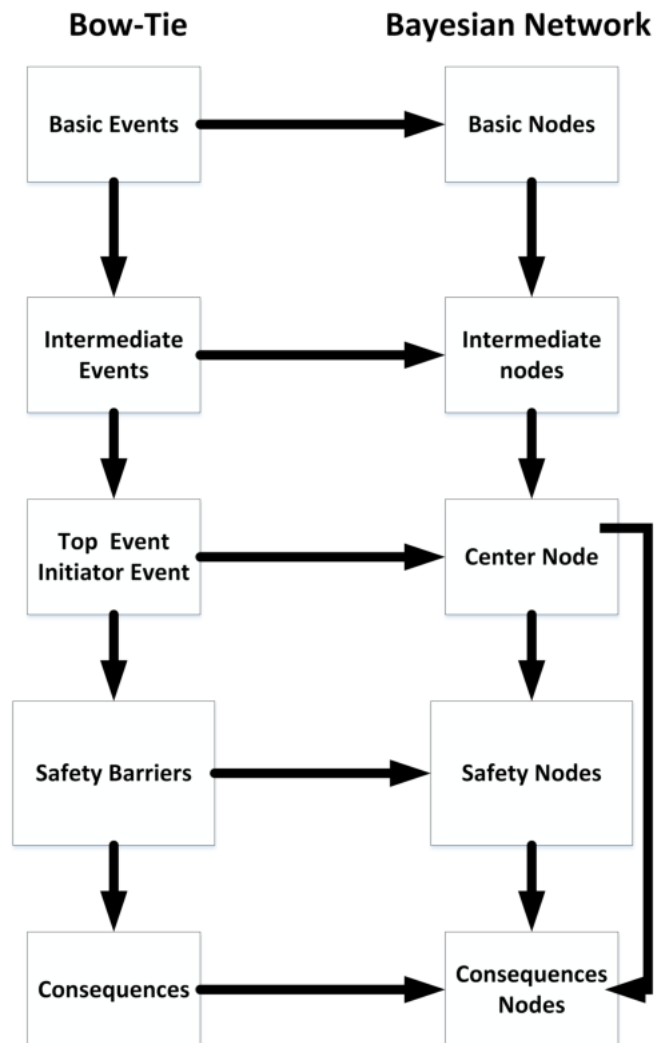

Figure 4.3: Mapping algorithm from BT into BN (Khakzad et al. 2013b)

4.3 Case study

4.3.1 Description of the process

Our case study focus on the LNG terminal of the plant GL4/Z in Arzew (west Algeria). Liquefied Natural Gas (LNG) includes component mixture mostly of methane and a small quantity of minor components such as; ethane, propane, nitrogen depending on the origin of natural gas. At atmospheric pressure, the boiling temperature of natural gas ranges from -166°C to -157°C and its flammability range in air is between 5% and 15% by volume

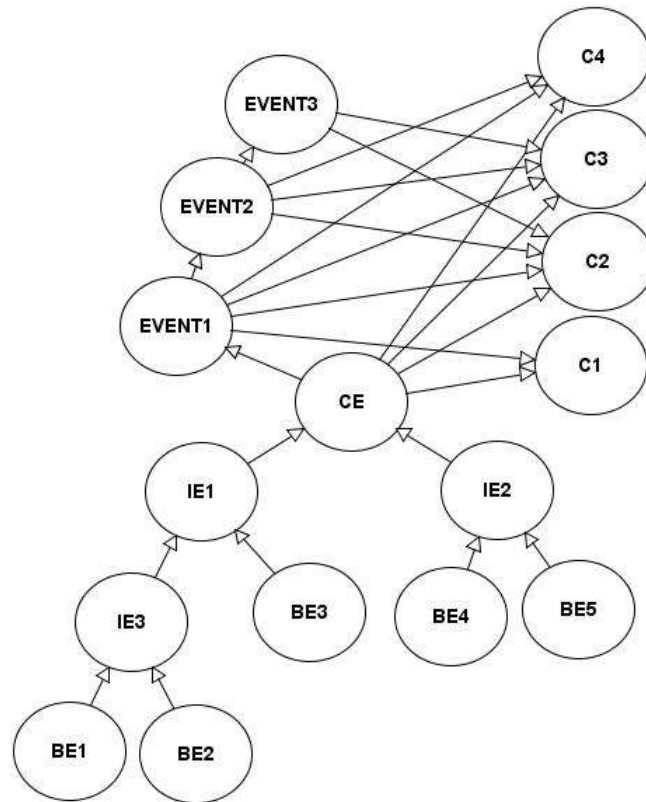

Figure 4.4: BN model for the BT example in Fig. 4.2 (C; consequence, IE; intermediate event, BE; basic event, CE; critical event, E; event).

(Bernatik et al. 2011). In general, The LNG train is comprised of four components: (1) exploration and production, (2) liquefaction, (3) shipping and (4) storage and regasification (Rathnayaka et al. 2012). When a flammable cloud is ignited it causes a vapor cloud explosion or flash fire. Also, a pool fire can appear when it exposure to an ambient heat source and in the existence of an ignition source. To avoid the aforementioned consequences, several safety measures are placed in LNG process facility among them; ignition prevention barrier and human factor barrier (Baksh et al. 2015). The simplified process flow diagram in Figure 4.5 represents the principal phases used in the majority of LNG plants. It is important to note that during the liquefaction phase, substances such as carbon dioxide (CO₂), water (H₂O) and Nitrogen (N₂) are removed to avoid freezing in the equipment since the temperature of natural gas decrease to -160C.

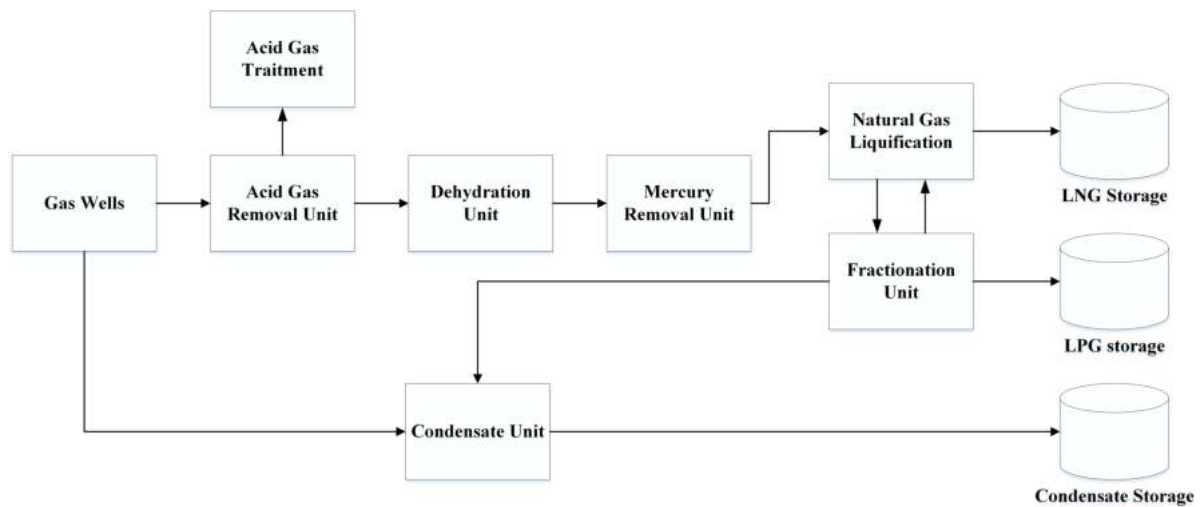

Figure 4.5: Simplified LNG plant block diagram.

4.3.2 Bow-Tie analysis

The BT of the accident scenarios is constructed as shown in Figure 4.6 most based on the work of (Kim et al. 2005)(Fethi 2006)(Rathnayaka et al. 2012)(Rathnayaka et al. 2013). Only the LNG storage, which is the last phase in Figure 4.5, is considered. The failure probabilities and the symbols of the basic events appear in Figure 4.6 and the different events are presented in Table 4.2 (American Institute of Chemical engineers 1989); (Mosleh and Fleming 1989), the safety barriers (SB) are depicted in Table 4.3, while the frequency of the outcomes for the LNG release is shown in Table 4.4. The failure of barriers is assumed independent and mutually exclusive and their description is presented as following (Rathnayaka et al. 2011):

Release prevention barrier (RPB):

the main initiating event that causes loss of containment is usually the release of materials. The principal elements lead to RPB failure are: (1) operational error prevention barrier failure (occur in operating condition often by manual operational errors), (2) physical or technical prevention barrier failure, (3) maintenance prevention barrier failure, (4) process upsets prevention barrier failure.

Dispersion prevention barrier (DPB):

Its function is to limit the extent and/or duration of hazardous events to prevent the propagation of material or energy (passive barriers such as retention walls and dikes and

active barriers such as ventilation and detection systems).

Ignition prevention barrier (IPB):

The failure of this barrier leads to an ignition of a flammable chemical mixture that may cause a fire and explosion. Ignition sources are multiples: flames, hot materials and gases, static electricity sparks, safety barriers are necessary to prevent fires and explosions whether are permanent passive barriers such as insulation, or permanent passive controllers such as inadvertent flame detection.

Escalation prevention barrier (EPB):

After ignition occurs, the hazardous event spread to closest equipment, causes more events what is known as a “domino effect”. Heat radiation, overpressure and fragment projection are the main physical effects that cause secondary events after the occurrence the primary ones. Passive safety barriers (fire wall, blast wall, etc.) and active barriers (fire suppression systems to prevent accidents such as jet or pool fires) are necessary to isolate the surroundings to prevent domino accident scenarios.

Human factor barrier (HFB):

The process operator takes full responsibility for the safe operation of the facility even with the modern automated safety systems and their intervention at all level is a crucial element when accidents occur. Many factors can cause HFB failure; these factors are allocated to five sub-safety barriers: information transfer barriers, working environment barriers, personal characteristics barriers, job and workplace design barriers, and a human-system interface barrier.

Management and organizational barrier (MOB):

One of the most causes for accident are management and organizational factors, the latter’s intervention may exist at all stages of the accident process. Their effect is difficult to measure because they change from process to another. The failure factors of these barriers are allocated to two sub-safety barriers: management barrier and the organizational barrier.

Table 4.2: Different components and events related to LNG release and their occurrence probabilities

Description	Symbols	Failure probability
Level indicator fails to indicate the right level	LI fail	8.70E-03
Operator fails to correctly observe level indicator	OLI fail	5.00E-02
Tank is being filled	T-filled	1
Operator fails to respond to increasing level	OIL1 fail	AND gate
Level switch high fail to actuate	LSH fail	8.70E-03
Operator fails to respond increasing level	OIL2 fail	5.00E-02
Tank Level increased during filling operation	TLI	AND gate
Operator fails to respond to high level	OHL fail	AND gate
Major LNG release from storage tank by overfilling	MLNG ovrf	AND gate
Major LNG release by failure of discharge pipes	LNG dis-pipe	3.00E-06
Major LNG release by loss of mechanical integrity of tank	LNG mech	3.00E-06
Major LNG release from storage tank by overpressurisation	LNG ovrrp	AND gate
Tank reaches vent pressure	vent	OR gate
Failure of safeguards for tank high pressure	Safeguards fail	AND gate
Tank pressure rises due to rollover	TPR rollover	1.00E-03
Tank pressure rises due to sudden drop in atmospheric pressure	TPR atm	1.00E-02
Operator fails to respond to high pressure	OHP fail	1.00E-02
Pressure control valve fails to open	PCV fail	2.50E-04
PSV fails to open at 35 g	PSV fail	2.12E-04
Major LNG release from storage tank by underpressurisation	MLNG pres	AND gate
Tank reaches vacuum relief pressure	VPV fail	AND gate
Natural gas admittance valve fails to open 25 g/cm ²	NGAV fail	2.12E-05
Tank pressure reaches to low pressure	TPI	OR gate
Operator fails to respond to low pressure	OLP fail	OR gate

Tank pressure drops due to abnormal increase in atmospheric pressure	TPD atm	1.00E-02
Vent PCV fails open	VPCV fail	2.12E-04
Pressure alarm low fails to actuate	ALARM fail	2.5 E -4
Operator fails to respond to tank low pressure	OLPT fail	1.00E-02

Table 4.3: Failure probability of the safety barriers.

Safety barrier	Failure probability
Release prevention barrier (RPB)	0.0527
Dispersion prevention barrier (DPB)	0.0616
Ignition prevention barrier (IPB)	0.106
Escalation prevention barrier (EPB)	0.0271
Human factor barrier (HFB)	0.0029
Management and organizational barrier (M&OB)	0.0421

Table 4.4: Consequences of the Major LNG release accident scenario.

Symbols	Consequences
C1	Safe
C2	Near miss
C3	Mishap
C4	Incident
C5	Accident (fire and explosion)

Table 4.4 shows five consequences that can occur from the major LNG release depending on the status of the safety barrier (success/failure), C1 represents the safe situation where non incident occur, one consequence represents the less dangerous accident scenarios which is C2 (near miss). Near miss represent an unplanned event that has the potential to cause, but does not actually, result in human injury, environmental pollution or equipment damage, or a divergence from a normal operation. However, C3,C4 and C5 represent the worse scenarios, which are pool fire, flash fire, fire and explosion, respectively. The results of the consequences from BT analysis are calculated and presented in Table 4.5.

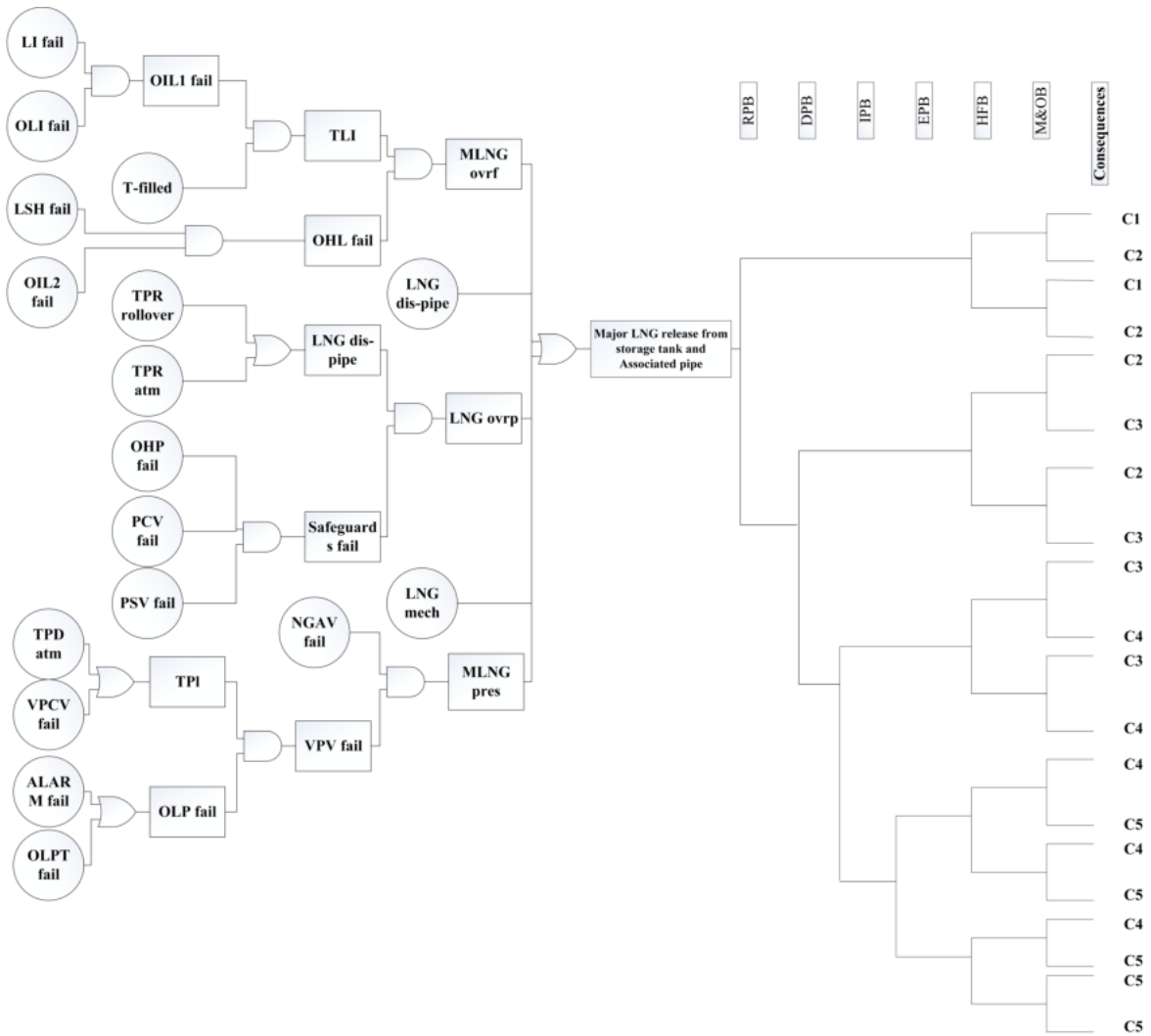

Figure 4.6: BT for the LNG release accident scenario.

Table 4.5: Accident analysis results from both BT and BN techniques.

Symbols	Prior probability (Pi)	
	<i>BT analysis</i>	<i>BN analysis</i>
Major LNG release	6.19E-06	6.19E-06
C1	0.9	0.9579
C2	0.04	0.03951
C3	3.00E-08	3.01E-08
C4	2.80E-09	2.80E-09
C5	8.90E-11	8.99E-11

4.3.3 Bayesian Networks Analysis

Based on the algorithm described in (Khakzad et al. 2013a) and the steps presented in section 4.2.2, the BN of the BT in Figure 4.7 is constructed and presented in Figure 4.6, the failure probabilities and the symbols of the basic events, the different barriers, and the consequences are presented in Table 4.2, Table 4.3, and Table 4.4, respectively. The BN is analyzed using AgenaRisk 6.2 (AgenaRisk 2016) (www.agenarisk.com), AgenaRisk is used for different types of modeling and applications (see Appendix A.2). The results of the consequences and the top event are similar to the BT analysis as shown in Table 4.5. The slight differences between the probabilities of consequences are due to the arc added from the top event (major LNG release) and the first barrier (RPB), indicating the dependence between these two nodes (the functioning of RPB is triggered by the occurrence of the top event).

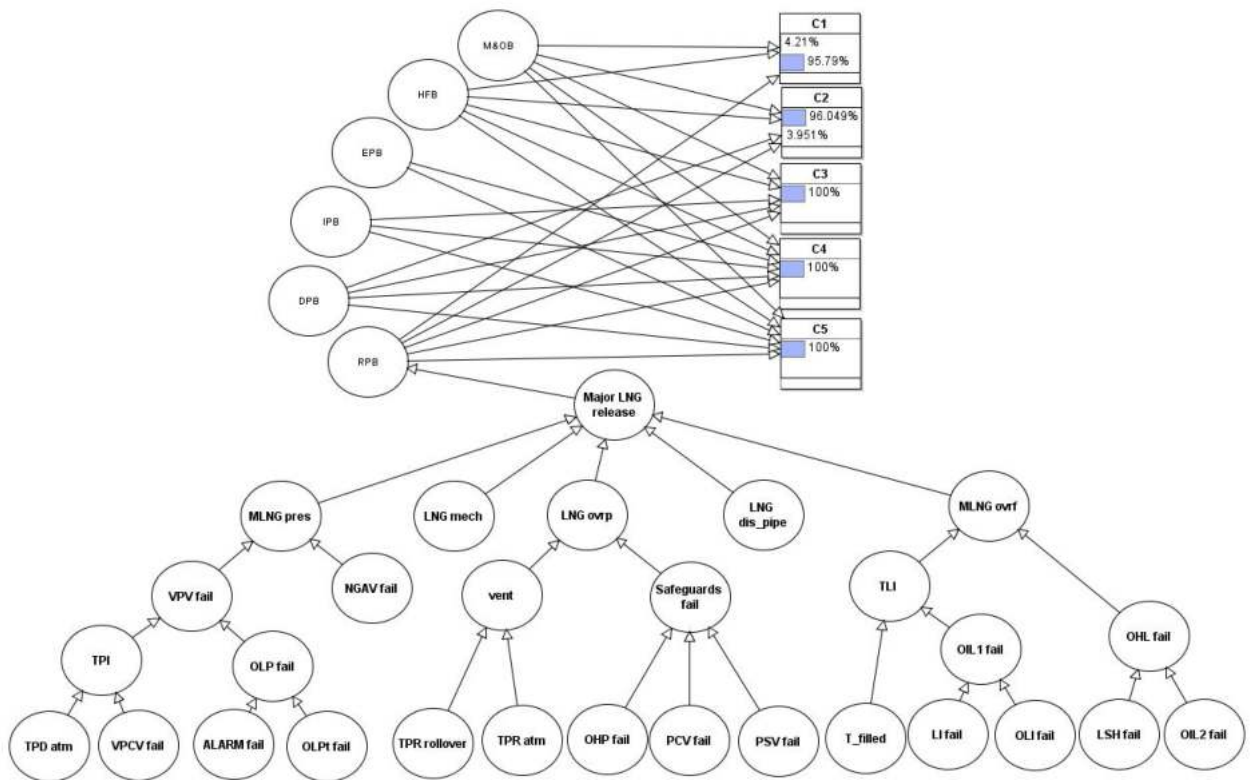

Figure 4.7: BN of the BT presented in Fig. 4.6.

4.4 Results and discussion

Unlike BT analysis, BN is able to perform probability-updating analysis, given new observations (Khakzad et al. 2011b). It may be observed from Table 4.6 that the occurrence probability (posterior probability) of the basic events: major LNG release by failure of discharge pipes (LNG dis_pipe), major LNG release by loss of mechanical integrity of tank (LNG mech), Level indicator fails to indicate the right level (LI fail), and Level switch high fail to actuate (LSH fail) have the highest increase. So, these components will be considered first to improve the safety of the process.

In addition, Table 4.7 shows that C4 “incident”, C3 “mishap”, and C5 Accident (fire and explosion) are the most likely consequences after the safe situation and near miss with probability of $4.5178E-4$, 0.004862 , and $1.4516E-5$, respectively.. The posterior probabilities of the basic events, the safety barriers and the consequences are calculated considering the Major release of LNG ($P(\text{Major LNG release})=1$).

The performances of the safety barriers are investigated considering the occurrence of the fire and explosion in the facility $P(C5)=1$. Table 4.8 shows the different results of prior and posterior probabilities of the safety barriers. It is noticed that the failure of the three first barriers (RPB, DPB, and IPB) and the Human factor barrier (HFB) leads to the occurrence of the fire and explosion. The results are clearly depicted in Figure 4.8 with the prior and posterior probabilities. We will run another evidence to show the importance of human factor in such industry, considering the failure of the first three barriers as depicted in Figure 4.9, this will lead automatically to the occurrence of C5 (fire and explosion). Thereafter, we will assume that the Human factor barrier is working 100%, from Figure 4.9, we can notice that the occurrence probability of C5 decreases from 1 to 0.0421, which indicates the effectiveness of the HFB.

Table 4.6: Diagnostic analysis of the basic events

<i>Basic event</i>	<i>Prior probability (Pi)</i>	<i>Posterior probability (Pf)</i>	<i>Ratio (Pf/Pi)</i>
LNG dis_pipe	3,00E-06	0.48454	1,62E+05
LNG mech	3,00E-06	0.48454	1,62E+05
OLP fail	1,00E-02	0.010347	1,03E+00
VPCV fail	2,12E-04	2.1936E-4	1,03E+00
ALARM fail	2,50E-04	2.5865E-4	1,03E+00
OLPt fail	1,00E-02	0.010346	1,03E+00
TPR rollover	1,00E-03	0.0010001	1,00E+00
TPR atm	1,00E-02	0.010001	1,00E+00
OHP fail	1,00E-02	0.010001	1,00E+00
PCV fail	2,50E-04	2.5094E-4	1,00E+00
PSV fail	2,12E-04	2.1294E-4	1,00E+00
T_filled	1	1	1,00E+00
LI fail	8,70E-03	0.038996	4,48E+00
OLI fail	5,00E-02	0.079034	1,58E+00
LSH fail	8,70E-03	0.038996	4,48E+00
OIL1 fail	5,00E-02	0.079034	1,58E+00

Table 4.7: Diagnostic analysis of the consequences.

<i>Consequences</i>	<i>Prior probability (Pi)</i>	<i>Posterior probability (Pf)</i>	<i>Ratio (Pf/Pi)</i>
C1	0.9579	0.90742	0,947301388
C2	0.03951	0.0848	2,146292078
C3	3.0103E-8	0.004862	161512,1416
C4	2.7971E-9	4.5178E-4	161517,2858
C5	8.9876E-11	1.4516E-5	161511,4157

Table 4.8: Diagnostic analysis of Safety barriers.

<i>Safety barrier</i>	<i>Prior probability (P_i)</i>	<i>Posterior probability (P_f)</i>	<i>Ratio (P_f/P_i)</i>
Release prevention barrier (RPB)	0,0527	1	18,97533207
Dispersion prevention barrier (DPB)	0,0616	1	16,23376623
Ignition prevention barrier (IPB)	0,106	1	9,433962264
Escalation prevention barrier (EPB)	0,0271	0,02905	1,07195572
Human factor barrier (HFB)	0,0029	0,005257	1,812758621
Management and organizational barrier (M&OB)	0,0421	0,99799	23,70522565

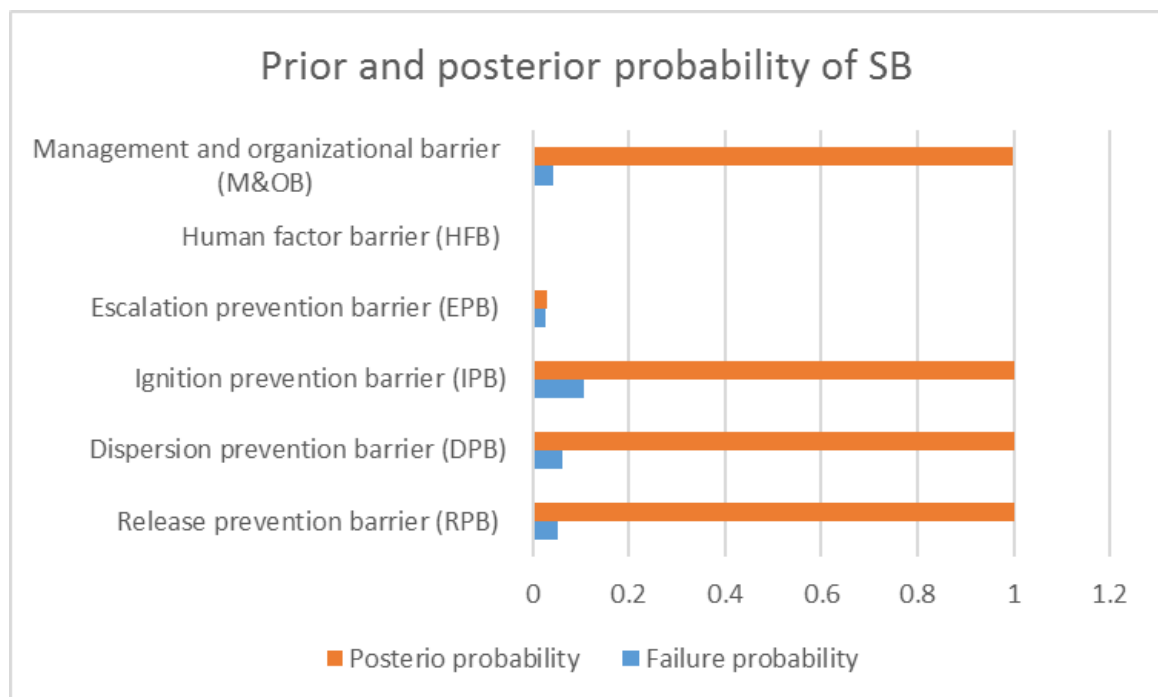

Figure 4.8: Prior and posterior probabilities of Safety Barriers.

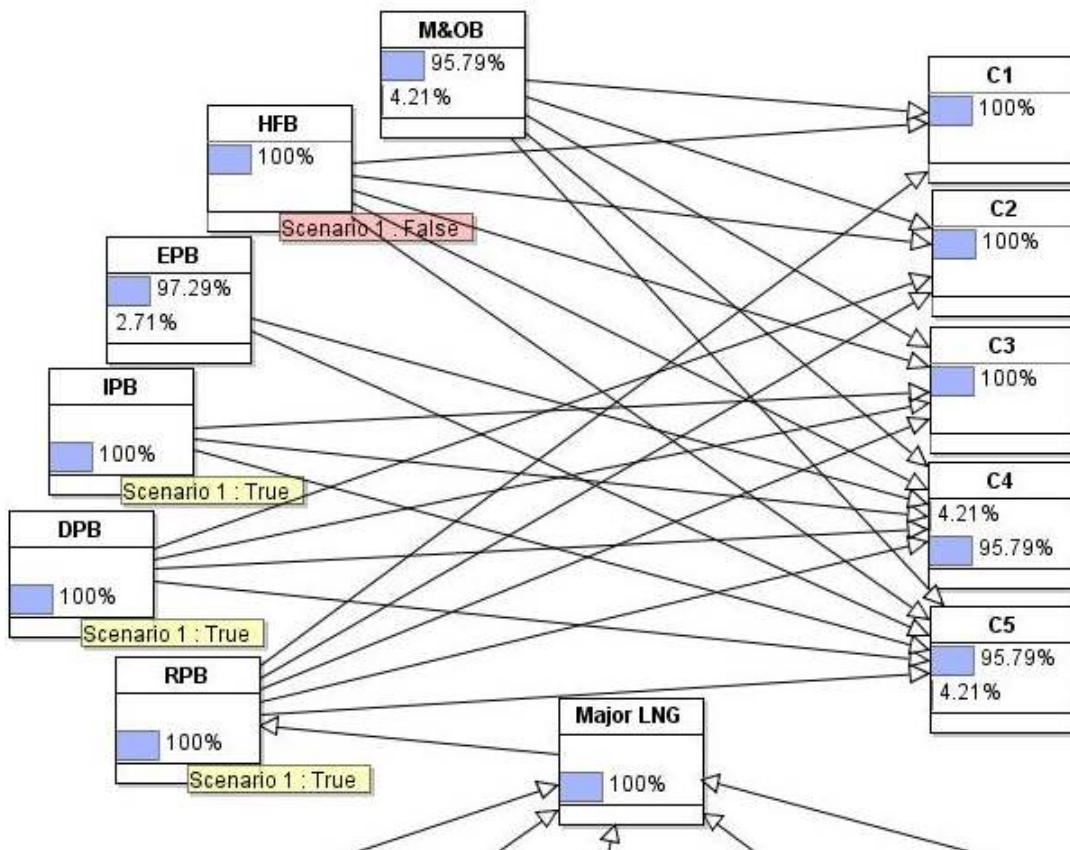

Figure 4.9: BN considering the failure of RPB, DPB, and IPB and the success of HFB.

In the next step, we will try to make the BN model constructed in Figure 4.7 less complicated and more understandable. Therefore, an OOBN is used for this purpose, we can notice that only the principals and connected nodes are shown in Figure 4.10. Major LNG release and the Barriers are presented as instance nodes and the consequences nodes are presented as usual node. Figure 4.11 shows an abstract model that contain only the main nodes from which our model is constructed. Also, the new OOBN model can be useful when adding new nodes such as common cause failures.

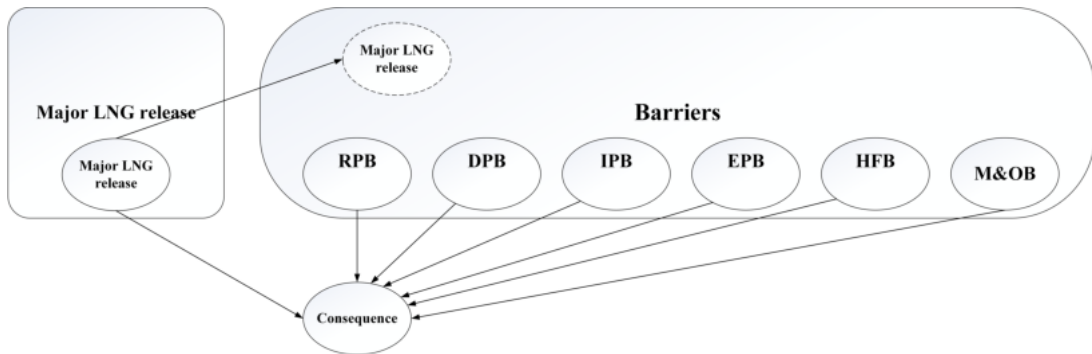

Figure 4.10: OOBN for Major LNG release

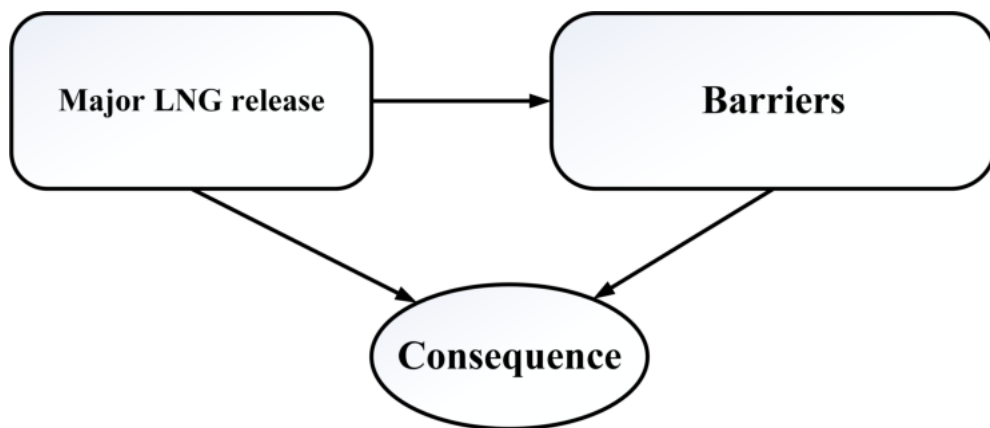

Figure 4.11: Collapsed form of the OOBN for Major LNG release

4.5 Conclusion

This study presents a risk assessment methodology based on Bow tie and Bayesian Networks for analyzing the safety critical components and the possible consequences of liquefied natural gas processing facility in Arzew (west Algeria). The results showed that Bayesian networks could overcome the limitation of Bow-tie technique practically in dependencies representation and updating probabilities. Moreover, BN used diagnostic (posterior) and predictive (prior) analysis to calculate the probabilities of the components and to predict the occurrence frequency of consequences when the undesired event occurs. In BN analysis, the posterior probability is used instead of risk acceptance criteria to present a good comprehension of the most dangerous consequences. BN present an excellent tool for decision-making when new information become available about the different nodes in the model (information about different events, safety barriers, or consequences). The fact that we used diagnostic analysis does not change the importance of risk

acceptance criteria because this latter defines the real value of the accepted risks while the first (diagnostic analysis) give the highest increase probability which is not always practicable. To abstract the model and for a good presentation, it is better to construct an OOBN for the complex and the large model. It is shown that the new OOBN model is became tractable and readable, also the dependencies between the main nodes were better understandable which facilitate the communication between the stakeholders.

References

- Abimbola M, Khan F, Khakzad N (2014) Dynamic safety risk analysis of offshore drilling. *J Loss Prev Process Ind* 30:74–85. doi: 10.1016/j.jlp.2014.05.002
- AgenaRisk (2016) AgenaRisk 6.2 Revision 2840. www.agenarisk.com.
- Ale BJM, Baksteen H, Bellamy LJ, et al (2008a) Quantifying occupational risk: The development of an occupational risk model. *Saf Sci* 46:176–185. doi: 10.1016/j.ssci.2007.02.001
- Ale BJM, Bellamy LJ, Baksteen H, et al (2008b) Accidents in the construction industry in the Netherlands: An analysis of accident reports using Storybuilder. *Reliab Eng Syst Saf* 93:1523–1533. doi: 10.1016/j.res.2007.09.004
- American Institute of Chemical engineers (1989) GUIDELINES FOR PROCESS EQUIPMENT RELIABILITY DATA with data tables.
- Aneziris ON, Papazoglou IA, Baksteen H, et al (2008) Quantified risk assessment for fall from height. *Saf Sci* 46:198–220. doi: 10.1016/j.ssci.2007.06.034
- Aqlan F, Mustafa Ali E (2014) Integrating lean principles and fuzzy bow-tie analysis for risk assessment in chemical industry. *J Loss Prev Process Ind* 29:39–48. doi: 10.1016/j.jlp.2014.01.006
- Badreddine A, Amor N Ben (2013) A Bayesian approach to construct bow tie diagrams for risk evaluation. *Process Saf Environ Prot* 91:159–171. doi: 10.1016/j.psep.2012.03.005
- Badreddine A, Romdhane T Ben, HajKacem MA Ben, Amor N Ben (2014) A new multi-objectives approach to implement preventive and protective barriers in bow tie diagram. *J Loss Prev Process Ind* 32:238–253. doi: 10.1016/j.jlp.2014.09.012
- Baksh AA, Khan F, Gadag V, Ferdous R (2015) Network based approach for predictive accident modelling. *Saf Sci* 80:274–287. doi: 10.1016/j.ssci.2015.08.003
- Barlow RE, Proschan F (1975) Importance of system components and fault tree events. *Stoch Process their Appl* 3:153–173. doi: 10.1016/0304-4149(75)90013-7

Bearfield G, Marsh W, Rail A, et al (2005) Generalising Event Trees Using Bayesian Networks with a Case Study of Train Derailment George. *Lect Notes Comput Sci* 3688:52–66.

Bellamy LJ, Ale BJM, Geyer TAW, et al (2007) Storybuilder-A tool for the analysis of accident reports. *Reliab Eng Syst Saf* 92:735–744. doi: 10.1016/j.ress.2006.02.010

Bernatik A, Senovsky P, Pitt M (2011) LNG as a potential alternative fuel - Safety and security of storage facilities. *J Loss Prev Process Ind* 24:19–24. doi: 10.1016/j.jlp.2010.08.003

Bhandari J, Abbassi R, Garaniya V, Khan F (2015) Risk analysis of deepwater drilling operations using Bayesian network. *J Loss Prev Process Ind* 38:11–23. doi: 10.1016/j.jlp.2015.08.004

Bobbio A, Portinale L, Minichino M, Ciancamerla E (2001) Improving the analysis of dependable systems by mapping Fault Trees into Bayesian Networks. *Reliab Eng Syst Saf* 71:249–260. doi: 10.1016/S0951-8320(00)00077-6

Deshpande A (2011) Fuzzy fault tree analysis: Revisited. *Int J Syst Assur Eng Manag* 2:3–13. doi: 10.1007/s13198-011-0049-6

Ferdous R, Khan F, Sadiq R, et al (2009) Handling data uncertainties in event tree analysis. *Process Saf Environ Prot* 87:283–292. doi: 10.1016/j.psep.2009.07.003

Ferdous R, Khan F, Sadiq R, et al (2013) Analyzing system safety and risks under uncertainty using a bow-tie diagram: An innovative approach. *Process Saf Environ Prot* 91:1–18. doi: 10.1016/j.psep.2011.08.010

Fethi E (2006) MSC in Asset Management with HSE Risk assessment and control of major hazard of LNG terminal at Sonatrach plant GL4/Z, Arzew. The robert gordon university aberdeen

Hong E-S, Lee I-M, Shin H-S, et al (2009) Quantitative risk evaluation based on event tree analysis technique: Application to the design of shield TBM. *Tunn Undergr Sp Technol* 24:269–277. doi: 10.1016/j.tust.2008.09.004

Jacinto C, Silva C (2010) A semi-quantitative assessment of occupational risks using bow-tie representation. *Saf Sci* 48:973–979. doi: 10.1016/j.ssci.2009.08.008

Khakzad N, Khan F, Amyotte P (2011) Safety analysis in process facilities: Comparison of fault tree and Bayesian network approaches. *Reliab Eng Syst Saf* 96:925–932. doi: 10.1016/j.ress.2011.03.012

Khakzad N, Khan F, Amyotte P (2013a) Dynamic safety analysis of process systems by mapping bow-tie into Bayesian network. *Process Saf Environ Prot* 91:46–53. doi: 10.1016/j.psep.2012.01.005

Khakzad N, Khan F, Amyotte P (2013b) Dynamic safety analysis of process systems by mapping bow-tie into Bayesian network. *Process Saf Environ Prot* 91:46–53. doi: 10.1016/j.psep.2012.01.005

Khakzad N, Khan F, Amyotte P (2012) Dynamic risk analysis using bow-tie approach. *Reliab Eng Syst Saf* 104:36–44. doi: 10.1016/j.res.2012.04.003

Kim H., Koh J-S., Kim Y., Theofanous TG. (2005) Risk assessment of membrane type LNG storage tanks in Korea-based on fault tree analysis. *Korean J Chem Eng* 22:1–8. doi: 10.1007/BF02701454

Langseth H, Portinale L (2007) Bayesian networks in reliability. *Reliab Eng Syst Saf* 92:92–108. doi: 10.1016/j.res.2005.11.037

Lavasani SM, Zendegani A, Celik M (2015) An extension to Fuzzy Fault Tree Analysis (FFTA) application in petrochemical process industry. *Process Saf Environ Prot* 93:75–88. doi: 10.1016/j.psep.2014.05.001

Mahmood YA, Ahmadi A, Verma AK, et al (2013) Fuzzy fault tree analysis: a review of concept and application. *Int J Syst Assur Eng Manag* 4:19–32. doi: 10.1007/s13198-013-0145-x

Markowski AS, Mannan MS, Bigoszewska A (2009) Fuzzy logic for process safety analysis. *J Loss Prev Process Ind* 22:695–702. doi: 10.1016/j.jlp.2008.11.011

Mosleh A, Fleming KN (1989) Analytical Background and Techniques Procedures for Treating Common Cause Failures in Safety and Reliability Studies. U.S. Nuclear Regulatory Commission

Nouri.Gharahasanlou A, Mokhtarei A, Khodayarei A, Ataei M (2014) Fault tree analysis of failure cause of crushing plant and mixing bed hall at Khoy cement factory in Iran. *Case Stud Eng Fail Anal* 2:33–38. doi: 10.1016/j.csefa.2013.12.006

Pearl J (1988) Probabilistic reasoning in intelligent systems: Networks of plausible inference. MORGAN KAUFMANN PUBLISHERS, INC., San Francisco, California

Ramzali N, Lavasani MRM, Ghodousi J (2015) Safety barriers analysis of offshore drilling system by employing Fuzzy event tree analysis. *Saf Sci* 78:49–59. doi: 10.1016/j.ssci.2015.04.004

Rathnayaka S, Khan F, Amyotte P (2013) Accident modeling and risk assessment framework for safety critical decision-making: application to deepwater drilling operation. *J Risk Reliab* 227:86–105. doi: 10.1177/1748006X12472158

Rathnayaka S, Khan F, Amyotte P (2012) Accident modeling approach for safety assessment in an LNG processing facility. *J Loss Prev Process Ind* 25:414–423. doi: 10.1016/j.jlp.2011.09.006

Rathnayaka S, Khan F, Amyotte P (2011) SHIPP methodology: Predictive accident modeling approach. Part I: Methodology and model description. *Process Saf Environ Prot* 89:151–164.

Rathnayaka S, Khan F, Amyotte P (2010) SHIPP methodology: Predictive accident modeling approach . Part II . Validation with case study. *Process Saf Environ Prot* 89:75–88. doi: 10.1016/j.psep.2010.12.002

Rausand M (2011) *Risk Assessment: Theory, Methods, and Applications*. John Wiley & Sons

Tucker O, Holley M, Metcalfe R, Hurst S (2013) Containment risk management for CO₂ storage in a depleted gas field, UK North Sea. *Energy Procedia* 37:4804–4817. doi: 10.1016/j.egypro.2013.06.390

Weber P, Jouffe L (2006) Complex system reliability modelling with Dynamic Object Oriented Bayesian Networks (DOOBN). *Reliab Eng Syst Saf* 91:149–162. doi: 10.1016/j.ress.2005.03.006

Weber P, Medina-Oliva G, Simon C, Iung B (2012) Overview on Bayesian networks applications for dependability, risk analysis and maintenance areas. *Eng Appl Artif Intell* 25:671–682. doi: 10.1016/j.engappai.2010.06.002

Yuan Z, Khakzad N, Khan F, Amyotte P (2015) Risk analysis of dust explosion scenarios using bayesian networks. *Risk Anal* 35:278–291. doi: 10.1111/risa.12283

Zadeh LA (1973) Outline of a new approach to the analysis of complex systems and decision processes. *Syst Man Cybern IEEE Trans* 28–44. doi: 10.1109/TSMC.1973.5408575

Zerrouki H, Smadi H (2017) Bayesian Belief Network Used in the Chemical and Process Industry: A Review and Application. *J Fail Anal Prev* 17:159–165. doi: 10.1007/s11668-016-0231-x

Zerrouki H, Tamrabet A (2015) Mapping Fault Tree into Bayesian Network in safety analysis of process system. In: *4th International Conference on Electrical Engineering (ICEE)*. IEEE, Boumerdes, pp 1–5

General Conclusion

In this thesis, we tried to discuss the advantages of Bayesian networks method in the field of safety and risk analysis in industrial process such as chemical plants. The latter usually deal with different products in high pressure/temperature, which make it more complex compared with other industries.

BN is become a prominent method that deal with the uncertainty and the complexity of the chemical plants and the process industries and the review presented in the second chapter showed a significant increase of the publication in this field.

Bayesian networks present an excellent method to model complex systems due to its flexible structure. In addition, BN can easily be mapped from well-known techniques (i.e. Fault tree, Event tree, and Bow tie), that make BN benefit from the features of the aforementioned techniques. By mapping these techniques to BN, we can extend our study as we explained in the third chapter. The multi-state variables modeling and dependent failures modeling can be performed in BN model unlike FT and BT, where the variables should be binary and independent. In addition, BN can be directly constructed based on an expert of the studied system. Even though, mapping BN from FT, ET, and BT still the most used method since they provide a good explanation of accident escalation. Another important feature of BN, which is updating probability of variable when new information become available referred to as posterior probability thanks to the use of Bayes' theorem. In the field of risk assessment, posterior probability can be used, for example by assuming the occurrence of a specific event or consequence and observe the behavior of the other variables (e.g. components or safety barriers).

Another advantage of BN is discussed, which is the sequential learning or probability adapting. Recently, the latter is widely used to conduct a dynamic revision of the prior probability in BN model. Using the sequential learning, we can predict the behaviour of the components in any system as we discuss in the third chapter which give the opportunity to improve the system's safety and avoid the accidents. By mapping Bow tie into Bayesian Networks, some benefits can be gained, such as dependencies representation

and updating probabilities. Also, by using posterior probabilities, we get an important information about the dangerous consequences when considering the occurrence of the unwanted event.

The following point can be summarized from chapter three:

- Each FT can be mapped to its corresponding BN, while a BN does not necessarily have an equivalent FT due to multi-state variables and sequentially dependent failures;
- Bayesian networks are used to dynamically update probabilities, it is a powerful method for updating in the light of new information;
- The number of an accident during a time interval is used as evidence to dynamically assess the system's safety and to predict the probability of the components.

Two different software for Bayesian networks modeling are used in this thesis which are Hugin lite and AgenaRisk, each of them have characteristics and benefits. However, we found that Hugin lite software is not suitable when we handle a large complex system with a huge number of nodes unlike AgenaRisk. This latter has proven its efficiency in this kind of modeling.

To facilitate the communication between the stakeholders and provide a certain level of abstraction for the large and complex system, it is better to build a model that present a good comprehension of the system with a reasonable level of simplicity. To this end, an OOBN is proposed to make the model more tractable and readable by presenting the principal and the main nodes with instance nodes and usual nodes. The new model shows a better understanding between the different nodes particularly the dependencies among the model.

Future works and perspectives

In the future, several points can be treated and some application can be proposed. For instance, only discrete random variables are considered in this thesis, while in the real word tasks, continuous variables are matter of interest. To do that, hybrid Bayesian network or enhanced Bayesian network can be used to solve this problem (Figure 4.12).

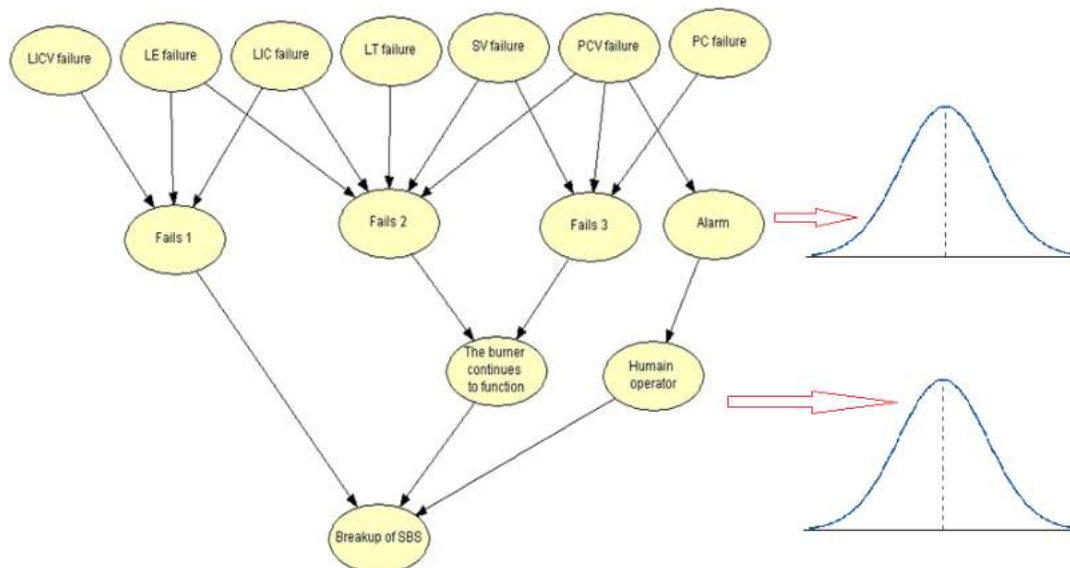

Figure 4.12: BN with discrete variables and continuous variables

In chapter 4, we can improve the study by:

- Determine critical basic events by means of probability updating or risk importance measures such as Birnbaum Importance Measure (BIM), Risk Achievement Worth (RAW), and Risk Reduction Worth (RRW) and then, compare them together;
- Determine minimal cut set (MCS) that lead to major release and rank them by importance degree;

- In addition, we can use consequence modeling for providing detailed and novel results by means of commercial softwares e.g. PHAST 7. Instead of qualitative survey of the consequences;
- It is necessary to use probability adapting to dynamically revise the safety barriers' probability and predict their behavior using a prior experience for an interval of time function in the LNG process;
- To complete the risk management process, risk deduction step must be done along with the safety engineer (expert of LNG process) by proposing some risk-reducing measure (safety barriers) to improve the level of safety within the process.

Appendix A

Appendix

A.1 Hugin history

Based on HUGINEXPERT website www.hugin.com, they defined Hugin as advanced decision support software for building decision analysis and support solutions in areas where reasoning under uncertainty is needed. The software owned by Aalborg University and the world's largest Bayesian Network research cluster. The collaboration between Aalborg University, and with academic institutions and commercial organizations in EU-funded research and development projects ensure the continuous development of Hugin. The latter is used for different application such as decision management solutions for diagnosis and prediction, fraud detection, credit risk assessment, anti-money laundering, operational risk management, food safety, troubleshooting and safety assessment, forensic identification and other applications.

A.2 AgenaRisk

AgenaRisk is a powerful software that is used for modeling risk and for making predictions about uncertain events. The software use developments from the field of artificial intelligence to analyze and compare different risks and make better decisions about uncertain problems. AgenaRisk combines the benefits of Bayesian Networks and statistical simulation, which make it powerful and flexible for different application particularly those involving uncertainty problems. Here are some applications of the software:

- Operational risk
- Business continuity

- Strategic planning and investment decision making
- Management of complex projects
- Procurement of critical military assets
- Ensuring the safety and reliability of critical systems

A.2.1 Types of Modeling in AgenaRisk

Thanks to the algorithms implemented in AgenaRisk, the following types of modeling can be performed:

- Representation of expert judgement using subjective probability
- Simulation of statistical distributions for predictive inference as an alternative to Monte Carlo simulation
- Diagnostic inference for machine learning applications
- Hierarchical modeling as an alternative to Monte Carlo Markov Chains (MCMC)
- Construction of hybrid models containing discrete and continuous uncertain variables
- Mixture modeling of discrete and continuous distributions
- Object oriented modeling of complex systems involving multiple objects and interfaces
- Dynamic modeling of time-based or evolving systems (such as Markov analysis)

More information about AgenaRisk can be found in the AgenaRisk official website www.agenarisk.com.

A.3 Importance of minimal cut-set (IM)

The importance of each minimal cut-set in a constructed model (fault tree analysis) help to identify the most likely MCS in the accident causation sequence. The importance of i th MCS is defined as:

$$IM_i = \frac{P(M_i)}{P(TE)}$$

Where, TE is the Top Event in Fault Tree analysis and M_i is the minimal cut-set.

ملخص

ان التطور الحاصل في المصانع الحديثة هو سيف ذو حدين، فمن جهة، هو يسهل طريقة الحياة ويوفر المتطلبات اليومية للفرد من سلع وخدمات، ومن جهة أخرى يمكن ان يتسبب في حوادث كارثية والتي ان لم يتعامل معها بشكل جيد، قد تؤدي الى خسائر في الأرواح، الممتلكات وحتى البيئة. ولتفادي الوقوع في مثل هذه الخسائر، يسعى الباحثون في هذا المجال الى اقتراح وتطوير عدة طرق ومناهج على غرار: شجرة الأخطاء، شجرة الاحداث، تحليل ربطة العنق، وشبكة بايز. يمكن تلخيص اهداف هذه الاطروحة في الخطوات التالية: (١) تقديم استعراض شامل لتطبيقات شبكة بايز في مصانع الكيماويات والمصانع العملية في العقد الأخير (٢٠١٦-٢٠٠٦) مع تطبيق بسيط لشبكة بايز على منشأة غاز. (٢) مناقشة وجيزة لمزايا شبكة بايز للقيام بتحليل السلامة والخطر بمقارنتها بالطريقة المعروفة شجرة الخطر (٣) دمج شبكة بايز في عملية إدارة المخاطر وتطبيقها على منشأة للغاز الطبيعي المسال، ثم بناء شبكة بايز ذات موضوع موجه للشبكات الفردية لجعل النموذج مختصر.

كلمات مفتاحية: شبكة بايز، شجرة الخطأ، شجرة الحدث، تحليل ربطة العنق، تقييم المخاطر، تحليل السلامة، مصانع الكيماويات، الاحتمال الخلفي، جدول الاحتمالات الشرطية.

Abstract

The development of nowadays industries is a two-edged sword, since it facilitate the way of living and provide the goods and services for the individual daily life requirements; on the other hand, it can cause catastrophic accidents that if not well handling could cause damage to human life, assets, and the environment. To avoid falling into these losses, researchers in this field proposed and developed several methods such as; Fault tree, Event tree, Bow tie, and Bayesian network. The main objectives of this thesis is to; (1) Present a well review on application of Bayesian network in the chemical plants and process industry within the last decade (2006-2016) and present a simple application of Bayesian network in gas facility. (2) Briefly discuss the advantages of Bayesian networks to conduct a safety and risk analysis over the well-known method Fault tree. (3) Integrate Bayesian network in the process of risk management and applied it to an LNG facility, then construct an object-oriented Bayesian network OOBN for the individual networks to abstract the model.

Keywords:

Bayesian network, Fault tree, Bow tie, Risk assessment, Safety analysis, Chemical plants, Posterior probability, Conditional probability table.

Résumé

Le développement des industries de nos jours est une épée à double tranchants, car il facilite la façon de vivre et de fournir les biens et les services pour les besoins quotidiens de la vie quotidienne d'une part; D'autre part, il peut causer des accidents catastrophiques que, si nous ne savons pas comment le manipuler, il pourrait conduire à des pertes humaines, de biens et même à l'environnement. Pour éviter de tomber dans ces pertes, les chercheurs dans ce domaine ont proposé et développé plusieurs méthodes telles que; Arbre de défaillance, Arbre de l'événement, Nœud de papillon et Réseau Bayésien. Les principaux objectifs de cette thèse sont : (1) Présenter un bon aperçu sur l'application du réseau bayésien dans les industrie des produits chimiques et des procédés au cours de la dernière décennie (2006-2016) et de présenter une application simple du réseau bayésien dans les installations de gaz. (2) Discuter brièvement les avantages de réseaux bayésiens pour effectuer une analyse de sécurité et de risque sur le méthodes connue ; Arbre de défaillance. (3) Intégrer le réseau bayésien dans le processus de gestion des risques et de l'appliquer à une installation de gaz naturel liquéfié, Puis construire un réseau bayésien orienté objet RBOO pour les réseaux individuels pour abstraire le modèle.

Mots-clés:

Réseaux Bayésiens, Arbre de défaillance, Arbre des événements, Nœud de papillon, Evaluation des risques, Analyse de sécurité, Les usines chimiques, probabilité a posteriori, table de probabilité jointe.