

DEPARTMENT OF MICROBIOLOGY AND BIOCHEMISTRY

N° ...../SNV/2021

THESIS

Presented by

**Leyla BENAMMAR**

For the fulfillment of the requirements for the degree of

**DOCTORATE OF SCIENCES**

Field: Biological Sciences

Specialty: Microbiology

THEME

**Study of the microbial biodiversity of  
terrestrial hydrothermal sources located in  
Eastern Algeria**

Public PhD Defense

December 7<sup>th</sup>, 2021

JURY

Chairman

Mohamed Mihoub ZERROUG

Prof. Univ. Batna 2, Algeria

Advisor

Ammar AYACHI

Prof. Univ. Batna 1, Algeria

Examiners

Kamel AISSAT

Prof. Univ. Batna 2, Algeria

Abdelkrim SI BACHIR

Prof. Univ. Batna 2, Algeria

Samia MEZAACHE-AICHOURE

Prof. Univ. Sétif 1, Algeria

Mabrouka BENHADJ

Dr. Univ. Tébessa, Algeria

## Acknowledgments

Firstly, I would like to thank my advisor **Prof. Ammar AYACHI**, Department of Veterinary Sciences, University of Batna 1, Algeria, for his constant encouragement, patience, guidance, and moral support throughout the research and preparation of the thesis. He welcomed me into his microbiology laboratory since the completion of my 'Magistère' thesis in 2009. Since then, I have always worked in this laboratory, gaining his trust and confidence. He always considered me a member of his family; I will never forget your support in difficult moments; I am grateful to you.

I am indebted to my co-supervisor, **Prof. Ali Osman BELDÜZ**, Department of Biology, Karadeniz Technical University, Trabzon, Turkey, for allowing me to work in his lab during my PNE scholarship. To improve myself as a scientist, and urged me to overcome many challenges that I thought impossible. I consider myself very fortunate to be able to work with a considerate and encouraging professor like him. I admire his persistence and enthusiasm as a scientist. This dissertation would not be accomplished without his generous help, careful guidance, and support.

My acknowledgments are also expressed to the dissertation committee members for their time, extreme patience, and intellectual contributions.

In particular, I wish to thank:

**Prof. Mohamed Mihoub ZERROUG** from the University of Mostefa Ben Boulaid, Batna 2, for kindly agreeing to chair the evaluation jury of this thesis.

**Prof. Samia MEZAACHE-AICHOOR** (University of Ferhat Abbas, Sétif 1), **Dr. Mabrouka BENHADJ** (University of Larbi Tebessi, Tébessa), **Prof. Abdelkrim SI BACHIR** (University of Mostefa Ben Boulaid, Batna 2) and, **Prof. Kamel AISSAT** (University of Mostefa Ben Boulaid, Batna 2) for the honor of being a jury member for examining and judging this work.

**Prof. Juan Miguel GONZALEZ** (Institute of Natural Resources and Agrobiology of Sevilla (IRNAS) Spain, for his generous help and for teaching me many molecular biology techniques I needed for my project.

**Prof. Amor HALITIM**, the ex-director of the research laboratory LAPAPEZA (Laboratory for The Improvement of Agricultural Production and Protection of Resources in Arid Zones), Department of Agricultural Sciences, University Batna1, for his help in providing a portable multiparameter meter used in all our *in situ* measurement.

**Prof. Nouzha HELEILI**, from the Department of Veterinary Sciences University of Batna 1, for the warm welcome during my work period in the HIDAOA laboratory.

I would like to thank all the members of the Molecular Biology Research laboratory: **Dr. Kadriye İNAN-BEKTAŞ**, **Dr. Dilşat Nigar ÇOLAK**, **Dr. İbrahim Halil GÜLER**, **Dr. Miray ŞAHINKAYA**, **Esmâ Nur YILDIZ**, and **Merve Ayşe DOĞANCI** for their care and immense help during my entire stay at Karadeniz Technical University, Trabzon, Turkey.

Special thanks to my friend and lab fellow **Dr. Miray ŞAHINKAYA** and her family for their generosity, love, and warm welcome in overcoming my foreignness. You were my second family in Turkey. I never forget our memories together; I will always be grateful to you.

I would also like to thank my father, **Dr. Abdelmadjid BENAMMAR**, who accompanied me during all my sampling trips, and for his technical assistance in sample collection.

I would like to thank my class and lab fellow **Dr. Taha MENASRIA** for his help, advice, encouragement, and support. The great friendship has made my Ph.D. life enjoyable.

I would also like to thank the **Ministry of Higher Education and Scientific Research of Algeria** and **the University of Batna 2** for the PNE scholarship and for providing a grant to Karadeniz Technical University, Trabzon, Turkey.

A special thanks to **my parents, two brothers, and sister** for bearing all the ups and downs of my research during many years, motivating me for higher studies, sharing my burden, and ensuring that I sailed through smoothly. Completing this work would not have been possible without my loving family members' unconditional support and encouragement.

**Leyla Benammar**

## TABLE OF CONTENTS

TABLE OF CONTENTS .....	i
ABSTRACT .....	v
RESUME.....	vi
ملخص.....	vii
SCIENTIFIC PUBLICATIONS .....	viii
LIST OF FIGURES.....	ix
LIST OF TABLES .....	xii
LIST OF ABBREVIATIONS .....	xiv

GENERAL INTRODUCTION .....	1
----------------------------	---

### **Chapter I. Culturable Thermophilic Bacteria and their Enzymatic Potential from Algerian Hot Springs**

<b>I. INTRODUCTION .....</b>	<b>8</b>
<b>II. MATERIALS AND METHODS</b>	
1. Site description.....	11
2. Sample collection .....	15
2.1. Water sampling.....	15
2.2. Sediment sampling.....	15
3. Physicochemical analysis .....	16
4. Isolation of thermophilic bacteria.....	16
4.1. Dilution plating.....	16
4.1.1. Sediment preparation.....	16
4.1.2. Serial dilution protocol.....	16
4.2. Liquid enrichment.....	17
5. Purification and preservation.....	17
5.1. Nomenclature of isolates .....	17
6. Phenotypic features of isolates .....	17
6.1. Morphological characterization .....	17
6.2. Biochemical characterization.....	18

6.2.1. Catalase test.....	18
6.2.2. Oxidase test .....	18
6.2.3. API 20E test system.....	18
6.3. Physiological characterization .....	18
7. SDS-PAGE of whole-cell proteins.....	19
7.1. Preparation of protein extracts.....	19
7.2. Protein essay .....	19
7.3. Sample preparation .....	19
7.4. SDS-PAGE electrophoresis migration.....	19
7.5. Staining and drying of the gel.....	20
7.6. Computing numerical data.....	20
8. Molecular identification by 16S rRNA sequencing and phylogenetic analysis.....	21
8.1. Genomic DNA extraction .....	21
8.2. Purity control and DNA concentration determination .....	21
8.3. PCR amplification.....	23
8.4. Agarose gel electrophoresis .....	23
8.5. Cloning of PCR products.....	24
8.5.1. Preparation of competent cells .....	26
8.5.2. Ligation of PCR product .....	26
8.5.3. Transformation .....	27
8.5.4. Verification of cloning .....	28
a. Plasmid isolation of transformed cell.....	28
b. Digestion of DNA with restriction enzyme .....	28
c. Plasmid isolation of clones by Kit .....	30
8.6. Sequencing and phylogenetic analysis .....	31
9. Screening of extracellular hydrolytic enzymes .....	32
9.1. Amylase activity .....	32
9.2. Cellulase activity.....	32
9.3. Pectinase activity .....	32
9.4. Esculinase activity .....	33
9.5. Protease activity .....	33
9.6. Gelatinase activity.....	33
9.7. Lipolytic activity.....	33

9.8. Lecithinase activity .....	33
9.9. Nuclease activity .....	33
10. Diversity data analysis .....	34
11. Statistical data analysis.....	34

### **III. RESULTS AND DISCUSSION**

1. Sampling sites and physicochemical analysis .....	35
2. Isolation and distribution of thermophilic bacteria .....	40
2.1. Distribution according to sampling sites .....	41
2.2. Distribution according to sample types.....	42
2.3. Distribution according to isolation methods and culture media .....	43
3. Preliminary characterization of isolates .....	47
3.1. Morphological characterization .....	47
3.2. Physiological characterization .....	49
4. SDS-PAGE analysis .....	49
5. Molecular identification and phylogenetic analysis .....	54
5.1. Amplification of 16S rRNA genes.....	54
5.2. Sequencing of the 16S rRNA genes .....	55
5.2.1. Cloning of the 16S rRNA genes.....	56
5.3. Phylogenetic characterization .....	58
5.4. Sequencing results of probably novel species .....	71
5.4.1. Physiological and biochemical characters.....	76
6. Biochemical characterization .....	78
7. Thermophilic bacterial diversity and evenness .....	80
8. Hydrolytic enzymes analysis.....	84
<b>VI. CONCLUSION .....</b>	<b>91</b>

## **Chapter II. Culture Independent Assessment of Microbial Diversity and Geochemistry of Two Algerian Hot Springs**

<b>I. INTRODUCTION</b> .....	92
<b>II. MATERIALS AND METHODS</b>	
1. Site description and samples collection.....	94
2. Analysis of environmental parameters .....	94
2.1. Total alkalinity .....	96
2.2. Total hardness .....	96
2.3. Total dissolved solids .....	96
2.4. Measure of cations .....	96
2.5. Nitrite .....	96
2.6. Chloride .....	96
2.7. Sulfate .....	97
2.8. Dry residue.....	97
3. Metagenomics sequencing .....	97
3.1. Genomic DNA extraction .....	97
3.2. Amplicon library preparation.....	97
3.3. Bioinformatic data analysis .....	99
4. Statistical data analysis.....	100
<b>III. RESULTS AND DISCUSSION</b>	
1. Site description and physicochemical characteristics .....	101
2. Thermal water classification .....	106
3. Drinkability of thermal water .....	106
4. Metagenomic sequencing analysis .....	109
5. Bacterial diversity analysis.....	121
6. Correlation between microbial diversity and physicochemical parameters .....	125
<b>VI. CONCLUSION</b> .....	<b>129</b>
<b>GENERAL CONCLUSION</b> .....	<b>130</b>
<b>REFERENCES</b> .....	<b>136</b>
<b>APPENDICES</b> .....	<b>157</b>

## ABSTRACT

Northeastern regions of Algeria are known for their richness in hot springs. However, these hydrothermal sites are yet to be explored for their microbial ecology and biotechnology. This research work aims to analyze and characterize the diversity of prokaryotes from hot springs located in the North-East of Algeria and expand the knowledge of this biodiversity from a functional and biotechnological standpoint. In the first instance, we determine the diversity of culturable thermophilic bacteria isolated from eight terrestrial hot springs distributed over four cities (Batna, Biskra, Guelma, and Khenchela) using conventional methods, SDS-PAGE fingerprinting of whole-cell proteins, and 16S rRNA gene sequencing. In addition, their hydrolytic enzyme activities were also investigated. On the other hand, the abundance and diversity of bacterial and archaeal communities in two Algerian hot springs relatively physiochemically distinct; Debagh hot spring (Guelma) and Saïda hot spring (Batna), was analyzed through a metagenomic based approach with high throughput sequencing (Illumina, MiSeq) and correlating the prevailing bacteria with geochemical parameters. A total of 293 strains were isolated from the hot springs water and sediment samples using different culture media. Overall, five distinct bacterial groups were characterized by whole-cell protein pattern analysis. Based on the 16S rRNA gene sequencing of 100 selected strains, the isolates were assigned to three major phyla: *Firmicutes* (93%), *Deinococcus-Thermus* (5%), and *Actinobacteria* (2%), which included 27 distinct species belonging to 12 different phylotypes, *Aeribacillus*, *Aneurinibacillus*, *Anoxybacillus*, *Bacillus*, *Brevibacillus*, *Geobacillus*, *Laceyella*, *Meiothermus*, *Saccharomonospora*, *Thermoactinomyces*, *Thermobifida*, and *Thermus*. The screening for nine extracellular enzymes showed that 65.87% of the isolates presented at least five types of enzyme activities, and 6.48% of strains combined all tested enzymes (amylase, cellulase, pectinase, esculinase, protease, gelatinase, lipase, lecithinase, and nuclease). It was found that *Bacillus*, *Anoxybacillus*, *Aeribacillus*, and *Aneurinibacillus* were the genera showing the highest activities. Likewise, the study showed a large and diverse thermophilic community with probably seven novel taxa presenting a promising source of thermozymes with critical biotechnological applications. Metagenome sequence data revealed the dominance of *Bacteria* over *Archaea*. The most abundant phyla in Saïda hot spring were *Proteobacteria*, while Debagh hot spring showed a high relative abundance of *Firmicutes*. However, *Bacteroidetes* were nearly equally distributed over the two sites. Although other phyla were also present in both thermal sites with different variations such as *Deinococcus-Thermus*, *Cyanobacteria*, *Chloroflexi*, *Acidobacteria*, *Chlorobi*, *Spirochaetes*, *Fibrobacteres*, *Verrucomicrobia*, *Nitrospirae*, and *Armatimonadetes*. The physicochemical values obtained from the hot springs water samples when plotted on Piper and Schöeller-Berkaloff diagrams suggested that the water from Debagh hot spring was Ca-Cl-SO<sub>4</sub> while Saïda hot spring was a sodium-sulfate type; these results revealed that the strong acidic anions (Cl<sup>-</sup>, SO<sub>4</sub><sup>2-</sup>) dominant over the weak acidic anions (CO<sub>3</sub><sup>2-</sup>, HCO<sub>3</sub><sup>-</sup>). The distribution of major genera and their statistical correlation analyses with the geochemistry of the springs predicted that the temperature, sodium, potassium, and alkalinity were the main environmental variables influencing the microbial community composition and diversity. This study on the diversity of thermophilic prokaryotes in Algerian hydrothermal environments revealed an abundant and diverse community, providing a valuable resource of novel taxa presenting potential sources of biocatalysts for important biotechnological applications.

---

**Keywords:** Algeria, hot spring, thermophile, diversity, SDS-PAGE fingerprinting, 16S rRNA gene, Next Generation Sequencing, hydrolytic enzymes.

## RESUME

Les régions du Nord-Est de l'Algérie sont connues pour leur richesse en sources chaudes. Ces sites hydrothermaux offrent une opportunité pour une exploration de leur écologie microbienne et de leur aspect biotechnologique. L'objectif de ce travail de recherche est d'analyser et de caractériser la diversité des procaryotes des sources chaudes situées dans le Nord-Est Algérien ainsi que d'étendre la connaissance de cette biodiversité d'un point de vue fonctionnel et biotechnologique. Dans un premier temps, nous avons déterminé la diversité des bactéries thermophiles cultivables isolées à partir de huit sources thermales terrestres réparties sur quatre villes (Batna, Biskra, Guelma et Khenchela) en utilisant des méthodes physiologiques et biochimiques conventionnelles, analyse du profil protéique par SDS-PAGE, et le séquençage du gène de l'ARNr 16S. En outre, leurs activités enzymatiques hydrolytiques ont été étudiées. D'autre part, l'abondance et la diversité des communautés bactériennes et archéennes de deux sources chaudes algériennes relativement distinctes sur le plan physicochimique : la source thermale de Debagh (Guelma) et de Saïda (Batna), ont été analysées par une approche métagénomique basée sur le séquençage à haut débit (Illumina, MiSeq), suivie de l'analyse des corrélations de la diversité bactérienne avec les paramètres géochimiques. Au total, 293 souches ont été isolées à partir des échantillons d'eau et de sédiments des sources hydrothermales en utilisant différents milieux de culture. Dans l'ensemble, cinq groupes bactériens distincts ont été caractérisés par l'analyse du profil protéique. Sur la base du séquençage du gène de l'ARNr 16S de 100 souches sélectionnées, les isolats ont été assignés à trois phyla principaux : *Firmicutes* (93%), *Deinococcus-Thermus* (5%) et *Actinobacteria* (2%), qui comprenait 27 espèces distinctes appartenant à 12 phylotypes différents, *Aeribacillus*, *Aneurinibacillus*, *Anoxybacillus*, *Bacillus*, *Brevibacillus*, *Geobacillus*, *Laceyella*, *Meiothermus*, *Saccharomonospora*, *Thermoactinomyces*, *Thermobifida* et *Thermus*. Le screening de neuf enzymes extracellulaires a montré que 65,87% des isolats présentaient au moins cinq types d'activités enzymatiques, et 6,48% des souches combinent toutes les enzymes testées (amylase, cellulase, pectinase, esculinase, protéase, gélatinase, lipase, lécithinase et nucléase). Il a été constaté que *Bacillus*, *Anoxybacillus*, *Aeribacillus* et *Aneurinibacillus* étaient les genres présentant les activités les plus élevées. De même, l'étude a montré une communauté thermophile abondante et diverse avec probablement sept nouveaux taxons présentant une source prometteuse de thermozymes avec des applications biotechnologiques importantes. Les données de séquence métagénomique ont révélé la prédominance des bactéries par rapport aux archées. Les phyla les plus abondants dans la source thermale Saïda étaient les *Proteobacteria*, tandis que la source de Debagh a montré une abondance relative élevée de *Firmicutes*. Les *Bacteroidetes* étaient répartis sur les deux sites à part égale. D'autres phyla étaient également présents dans les deux sites thermaux avec des variations différentes comme *Deinococcus-Thermus*, *Cyanobacteria*, *Chloroflexi*, *Acidobacteria*, *Chlorobi*, *Spirochaetes*, *Fibrobacteres*, *Verrucomicrobia*, *Nitrospirae* et *Armatimonadetes*. Les paramètres physico-chimiques obtenus à partir des échantillons d'eau des sources thermales, reportés sur les diagrammes de Piper et de Schöeller-Berkaloff, suggèrent que l'eau de la source de Debagh est de type chloruro-sulfato-calcique tandis que celle de la source chaude de Saïda est de type sulfaté-sodique. La distribution des principaux genres et leurs analyses de corrélation statistique avec la géochimie des sources ont permis de prédire que la température, le sodium, potassium et l'alcalinité étaient les principaux facteurs environnementaux influençant la composition et la diversité de la communauté microbienne. Cette étude sur la diversité des procaryotes thermophiles dans les environnements hydrothermaux algériens a révélé une communauté abondante et diversifiée, fournissant une ressource précieuse de nouveaux taxons, présentant une source potentielle de biocatalyseurs pour diverses applications biotechnologiques.

---

**Mots clés :** Algérie, source thermale, thermophile, diversité, SDS-PAGE, ARNr 16S, séquençage de nouvelle génération, enzymes hydrolytiques.

## ملخص

تشتهر المناطق الشمالية الشرقية من الجزائر بغناها بالينابيع الساخنة. ومع ذلك، فإن هذه المواقع المائية الحرارية لم يتم استكشاف بيئتها الميكروبية والتكنولوجيا الحيوية بعد. الهدف من هذا البحث هو تحليل وتوصيف التنوع البكتيري في الينابيع الساخنة الواقعة في شمال شرق الجزائر بالإضافة إلى توسيع المعرفة بهذا التنوع البيولوجي من وجهة نظر وظيفية وبيوتكنولوجية. في المقام الأول، حددنا تنوع البكتيريا المحبة للحرارة القابلة للزراعة المعزولة من ثمانية ينابيع أرضية ساخنة موزعة على أربع مدن (باتنة، بسكرة، قالمة، وخنشلة) باستخدام الطرق الميكروبيولوجية التقليدية، تحليل البصمة البروتينية عن طريق SDS-PAGE، والتسلسل الجيني للحمض النووي الريبوزي ARNr 16S. بالإضافة إلى ذلك، تم أيضاً فحص أنشطة الإنزيمات المحللة. من ناحية أخرى، فإن وفرة وتنوع المجتمعات البكتيرية في اثنين من أهم الينابيع الساخنة الجزائرية المميزة نسبياً من الناحية الفيزيوكيميائية؛ دفعا إلى دراسة حمام دباغ (قالمة) وبنوع سعيدة الحار (باتنة) من خلال نهج قائم على الميتاجينوم مع تسلسل عالي الإنتاجية (Illumina, MiSeq) وكذا مدى ارتباط التنوع البكتيري بالخصائص الفيزيوكيميائية لهذه الينابيع الحارة. تم عزل ما مجموعه 293 سلالة من عينات مياه الينابيع الساخنة ورواسبها باستخدام وسائل استزراع مختلفة. بشكل عام، أظهرت نتائج تحليل النمط البروتيني خمس مجموعات بكتيرية متنوعة. بناءً على التسلسل الجيني ARNr 16S لـ 100 سلالة مختارة، تم تعيين العزلات لثلاث شعب رئيسية: (93%) *Firmicutes*، مختلف، *Deinococcus-Thermus* (5%) و *Actinobacteria* (2%) والتي تضمنت 27 نوعاً متميزاً ينتمون إلى 12 جنس مختلف، *Geobacillus*، *Brevibacillus*، *Bacillus*، *Anoxybacillus*، *Aneurinibacillus*، *Aeribacillus*، *Thermobifida*، *Thermoactinomyces*، *Saccharomonospora*، *Meiothermus*، *Laceyella* و *Thermus*. أظهر فحص تسع إنزيمات أن 65.87% من العزلات قدمت ما لا يقل عن خمسة أنواع من الأنشطة الإنزيمية، و6.48% من السلالات جمعت جميع الإنزيمات المختبرة (الأميلاز، السليولاز، البكتيناز، الإسكوليناز، البروتياز، الجيلاتيناز، الليباز، الليسيثيناز، والنيوكلياز). وجد أن *Aeribacillus*، *Anoxybacillus*، *Bacillus* و *Aneurinibacillus* كانت الأجناس التي أظهرت أعلى الأنشطة الإنزيمية. وبالمثل، أظهرت الدراسة أيضاً مجتمعاً وفيراً ومتنوعاً محباً للحرارة مع احتمالية تصنيف سبعة عزلات كأصناف بكتيرية جديدة تقدم مصدراً واعدًا للترموزيمات للاستخدام في عدة تطبيقات بيوتكنولوجية مهمة. كشفت بيانات تسلسل الميتاجينوم عن هيمنة البكتيريا على حساب العتائق. كانت الكائنات الحية الأكثر وفرة في بنوع سعيدة هي البكتيريا المتقلبة *Proteobacteria*، بينما أظهر نبع دباغ وفرة نسبية عالية من مئينات الجدار *Firmicutes*. تم توزيع بكتيريا العصوانيات *Bacteroidetes* بالتساوي على الموقعين. كانت الشعب الأخرى موجودة أيضاً في الموقعين الحارين مع اختلاف التوزيع مثل *Deinococcus-Thermus*، *Cyanobacteria*، *Chloroflexi*، *Acidobacteria*، *Chlorobi*، *Spirochaetes*، *Fibrobacteres*، *Verrucomicrobia*، *Nitrospirae*، و *Armatimonadetes*. تشير المعلومات الفيزيائية والكيميائية التي تم الحصول عليها من عينات المياه من الينابيع الحارة، الواردة في مخططات بايبر وشولر-بيركالوف، إلى أن مياه نبع دباغ هي من نوع الكلور وكبريتات الكالسيوم بينما مياه الينابيع الساخنة في سعيدة هي من نوع كبريتات الصوديوم. توقع توزيع الشعب الرئيسية وتحليلات ارتباطها الإحصائي بالكيمياء الجيولوجية للينابيع بينت أن درجة الحرارة، الصوديوم، البوتاسيوم وقلوية الماء كانت المتغيرات البيئية الرئيسية التي تؤثر على تكوين المجتمع الميكروبي وتنوعه. كشفت هذه الدراسة حول تنوع بدائيات النوى المحبة للحرارة في البيئات الحرارية المائية الجزائرية عن وجود مجتمع وفير ومتنوع، يوفر مورداً قيماً لأنواع بكتيرية جديدة، ويقدم مصادر محتملة للإنزيمات المقاومة للحرارة بغرض تحسين التطبيقات البيوتكنولوجية.

**الكلمات المفتاحية:** الجزائر، منبع حراري، بكتيريا محبة للحرارة، تنوع، SDS-PAGE، جين ARNr 16S، تسلسل الجيل التالي، إنزيمات محللة.

## SCIENTIFIC PUBLICATIONS

**1. Benammar L., Ayachi A., İnan Bektaş K., Menasria T., Beldüz, A.O., Güler H.I., Bedaida I.K., and Gonzalez J.M. (2020). Diversity and enzymatic potential of thermophilic bacteria associated with terrestrial hot springs in Algeria. *Brazilian Journal of Microbiology*. 51, 1987–2007. <https://doi.org/10.1007/s42770-020-00376-0>.**

**2. Benammar L. and Menasria T. (2021). Comparative metagenomics analysis of microbial diversity between two hot springs in Algeria. (Under review).**

## COMMUNICATIONS

**1. Benammar L., Ayachi A., Beldüz A.O., İnan Bektaş K., Güler H.I., Nigar Çolak D., Şahinkaya M., Çanakçı S. Biocatalytic potential of thermophilic bacteria isolated from Algerian hot springs. 2nd International Unidokap Black Sea Symposium on BIODIVERSITY 28-30 November 2018 -Ondokuz Mayıs University- SAMSUN, TURKEY. (Oral Communication).**

**2. Benammar L., Beldüz A.O., İnan Bektaş K., Menasria T., Şahinkaya M., Çanakçı S., Bedaida I.K., Ayachi, A. Biodiversity of thermophilic bacteria from Algerian hot springs. Eurasian Congress on Molecular Biotechnology (ECOMB 2019) 19-21 September 2019, TRABZON, TURKEY. (Poster Communication).**

## List of figures

### CHAPTER I.

---

<b>Figure 1.</b> Location map of the sampled sites (North-East of Algeria) .....	12
<b>Figure 2.</b> The different prospected hot springs.....	14
<b>Figure 3.</b> Cellular DNA extraction by the Wizard® Genomic DNA Purification Kit .....	22
<b>Figure 4.</b> The promoter and multiple cloning sequence of the pGEM®-T Easy Vectors.....	24
<b>Figure 5.</b> The pGEM®-T Easy Vector circle map and sequence reference points .....	25
<b>Figure 6.</b> Schematic representation of restriction digestion of EcoRI at a specific site on the DNA fragments .....	29
<b>Figure 7.</b> Plasmid isolation by the GeneJET Plasmid Miniprep Kit.....	31
<b>Figure 8.</b> Distribution of isolates from sediment and water-based on sampling sites.....	41
<b>Figure 9.</b> Frequency of isolates from water and sediment samples.....	42
<b>Figure 10.</b> Isolation frequency of thermophilic bacteria. (A) Depending on the type of culture media (B) On the nature of media (C) On the isolation technique.....	44
<b>Figure 11.</b> Different phenotypic aspects of some thermophilic isolates .....	48
<b>Figure 12.</b> Dendrogram of similarity based on SDS-PAGE of whole-cell protein pattern analysis from thermophilic bacterial isolates. The right side of the figure represents the strains number.....	51
<b>Figure 13.</b> PCR amplification products of the 16S rRNA gene from seven isolates. (L): ladder GeneRuler 1Kb DNA, (C): negative control.....	55
<b>Figure 14.</b> Gel electrophoresis of recombinant plasmids isolated from white colonies by the alkaline lysis method.....	57
<b>Figure 15.</b> Digestion of different 16S rRNA cloned plasmids using EcoRI restriction enzyme .....	57
<b>Figure 16.</b> The total number of thermophilic isolates for each genus .....	59
<b>Figure 17.</b> The number of distinct species in each isolated genus .....	59

<b>Figure 18.</b> Neighbor-joining phylogenetic tree showing the relationship between <i>Firmicutes</i> isolates ( <i>Paenibacillaceae</i> and <i>Thermoactinomycetaceae</i> ) and closely related species based on 16S rRNA gene sequence comparison .....	65
<b>Figure 19.</b> Neighbor-joining phylogenetic tree showing the relationship between <i>Bacillaceae</i> isolates and closely related species based on 16S rRNA gene sequence comparison .....	66
<b>Figure 20.</b> Neighbor-joining phylogenetic tree showing the relationship based on 16S rRNA gene sequence comparison of (A) <i>Deinococcus-Thermus</i> , (B) <i>Actinobacteria</i> .....	69
<b>Figure 21.</b> Phylogenetic trees based on the sequence analysis of the gene encoding 16S rRNA showing the relationships between the 40S14, 40S27, and 05S21 strains with the type species of the closest genera .....	73
<b>Figure 22.</b> Phylogenetic trees based on the sequence analysis of the gene encoding 16S rRNA showing the relationships between the 24G5, 24G6, 07S27, and 07S20 strains with the type species of the closest genera.....	74
<b>Figure 23.</b> Dendrogram of API 20E profiles from thermophilic bacteria isolated from hot springs based on UPGMA cluster analysis and the Jaccard similarity coefficient .....	79
<b>Figure 24.</b> The number of thermophilic isolates from the different hot springs. Saïda (H05S) Guerdjima (H05G), Sidi El Hadj (H07S), Essalihine (H40S), El Knif (H40K), Debagh (H24D), Belhachani (H24A), and Guerfa (H24G) .....	80
<b>Figure 25.</b> Venn diagram distribution illustrates the number of exclusive and common thermophilic bacterial isolates among the sampled sites. Each ellipse represents a sampling city point.....	81
<b>Figure 26.</b> Frequency distribution of hydrolytic enzymes among the thermophilic strains ....	84
<b>Figure 27.</b> Screening of hydrolytic enzymes production by typical thermophilic bacteria isolated from Algerian hot springs .....	85
<b>Figure 28.</b> Distribution of extracellular hydrolytic enzymes from isolated thermophilic bacteria .....	88

## CHAPTER II.

---

<b>Figure 1.</b> Location map of the sampled sites Debagh hot spring (Guelma) and Saïda hot spring (Batna).....	95
<b>Figure 2.</b> The Qiagen DNeasy PowerSoil DNA isolation procedure.....	98
<b>Figure 3.</b> Correlogram based on Pearson correlation determining interactions between the main hydrochemical parameters.....	105
<b>Figure 4.</b> The Piper trilinear diagram representing the chemical facies of the two thermal springs water .....	107

<b>Figure 5.</b> The Schöeller-Berkaloff diagram displaying the two thermal springs water .....	108
<b>Figure 6.</b> Relative abundance of the microbial kingdom in analyzed water and sediment from the two hot springs. ....	110
<b>Figure 7.</b> Relative abundance of the bacterial phyla in four samples from the two hot springs (Debagh and Saïda) .....	112
<b>Figure 8.</b> Relative abundance of the bacterial classes in four samples from the two hot springs (Debagh and Saïda) .....	117
<b>Figure 9.</b> Relative abundance of the bacterial families in four samples from the two hot springs (Debagh and Saïda) .....	118
<b>Figure 10.</b> Relative abundance of the bacterial genera in four samples from the two hot springs (Debagh and Saïda) .....	119
<b>Figure 11.</b> Heat map indicating the clustering of OTUs retrieved from the hot spring samples at the genus level .....	120
<b>Figure 12.</b> Venn diagram showing the distribution of unique and shared OTUs (A) within various sample types (B) within the two hot springs. ....	123
<b>Figure 13.</b> Rarefaction curves for the four samples from Debagh and Saïda hot springs. ....	124
<b>Figure 14.</b> Principal coordinate analysis (PCA) illustrates the distribution of the major phyla among bacterial communities in the two hot springs .....	126
<b>Figure 15.</b> Correlogram based on Pearson correlation presenting the effect of physicochemical parameters on microbial composition and diversity.....	127

## List of Tables

### CHAPTER I.

---

<b>Table 1.</b> Geographic details of sampling sites .....	11
<b>Table 2.</b> Date and nature of samples from each thermal spring .....	15
<b>Table 3.</b> Composition of polyacrylamide-SDS gels used for the separation of proteins by SDS-PAGE .....	20
<b>Table 4.</b> Ligation reaction mixture composition.....	27
<b>Table 5.</b> Mixture composition of restriction enzyme digestion reaction .....	29
<b>Table 6.</b> Physicochemical characteristics of sampling sites .....	35
<b>Table 7.</b> Outcomes of ANOVA testing the effect of sampling site, samples type, culture media, and culture methods on the number of thermophilic isolates.....	46
<b>Table 8.</b> Thermophilic bacteria isolated from Algerian hot springs and their best match results with typed strains 16S rRNA gene sequences.....	60
<b>Table 9.</b> Phylogenetic classification of the thermophilic isolates .....	62
<b>Table 10.</b> Probably novel species description information and the similarity frequency with the type strain .....	71
<b>Table 11.</b> BLAST result of the 16S rRNA gene sequence of the strain 07S20 with the type strains of the species belonging to the genus <i>Bacillus</i> .....	75
<b>Table 12.</b> BLAST result of the 16S rRNA gene sequence of the strain 07S27 with the type strains of the species belonging to the genus <i>Bacillus</i> .....	75
<b>Table 13.</b> BLAST result of the 16S rRNA gene sequence of the strain 05S21 with the type strains of the species belonging to the genus <i>Thermoactinomyces</i> .....	75
<b>Table 14.</b> BLAST result of the 16S rRNA gene sequence of the strain 24G5 with the type strains of the species belonging to the genus <i>Geobacillus</i> .....	75
<b>Table 15.</b> BLAST result of the 16S rRNA gene sequence of the strain 24G6 with the type strains of the species belonging to the genus <i>Geobacillus</i> .....	75
<b>Table 16.</b> BLAST result of the 16S rRNA gene sequence of the strain 40S27 with the type strains of the species belonging to the genus <i>Brevibacillus</i> .....	76
<b>Table 17.</b> BLAST result of the 16S rRNA gene sequence of the strain 40S14 with the type strains of the species belonging to the genus <i>Aneurinibacillus</i> .....	76
<b>Table 18.</b> Species richness and diversity of identified thermophilic bacteria in surveyed hot springs .....	82

## CHAPTER II.

---

**Table 1.** Physicochemical characteristics of the water samples collected from Saïda and Debagh springs (North-East, Algeria) ..... 102

**Table 2.** Estimated diversity indices for thermophilic bacteria from the two hot springs..... 122

## List of abbreviations

**Abs230/Abs260/Abs280:** Absorbance at 230-260 and 280nm

**API 20E :** Appareils et Procédés d'Identification (*Enterobacteria*)

**ATCC:** American Type Culture Collection

**BLASTn:** Basic Local Alignment Search Tool for nucleotide

**bp:** Base Pair

**BSA:** Bovine Serum Albumin

**BstZI:** name of a restriction enzyme isolated from *Bacillus stearothermophilus*, I, denotes that it was the first enzyme isolated from this strain

**CaCl<sub>2</sub>:** Calcium Chloride

**CaCO<sub>3</sub>:** Calcium Carbonate

**CCD:** Charged Coupled Device

**Cl<sup>-</sup>:** Chloride

**CLUSTAL-X:** a bioinformatics computer program of multiple sequence alignment. X; with a graphical user interface

**CMC:** CarboxyMethyl-Cellulose

**DNA:** Deoxyribonucleic Acid

**dNTPs:** Deoxyribonucleotide Triphosphate

**EC:** Electrical Conductivity

**EcoRI:** *Escherichia coli*, strain RY13 I, denotes that it was the first enzyme isolated from this strain (name of a restriction enzyme)

**EDTA:** Ethylenediamine Tetraacetic Acid

**EtBr:** Ethidium Bromide

**F:** Forward

**FASTA:** File format/ is a text-based format for representing either nucleotide sequences or amino acid (protein) sequences, in which nucleotides or amino acids are represented using single-letter codes

**H05S:** Saïda Hot Spring

**H05G:** Guerdjima Hot Spring

**H07S:** Sidi El Hadj Hot Spring

**H24A:** Belhachani Hot Spring

**H24D:** Debagh Hot Spring

**H24G:** Guerfa Hot Spring

**H40S:** Essalihine Hot Spring

**H40K:** El Knif Hot Spring

**HCO<sub>3</sub><sup>-</sup>:** Hydrogen Carbonate

**IPTG:** Isopropyl-Thio-Galactoside

**JPEG:** Joint Photographic Experts Group

**KB:** Kilobase

**kDa:** KiloDalton

**K<sub>2</sub>HPO<sub>4</sub>:** Dipotassium Phosphate

**LB:** Luria-Bertani

**LPSN:** List of Prokaryotic names with Standing in Nomenclature

**MEGA:** Molecular Evolutionary Genetics Analysis

**NCBI:** National Center for Biotechnology Information

**NGS:** Next Generation Sequencing

**OTU:** Operational Taxonomic Unit

**PCR:** Polymerase Chain Reaction

**PES:** Polyether-sulfone

**SDS-PAGE:** Sodium Dodecyl Sulphate–Polyacrylamide Gel Electrophoresis

**SO<sub>4</sub><sup>2-</sup>:** Sulfate

**SRB:** Sulfate Reducing Bacteria

**TDS:** Total Dissolved Solids

**TE:** Tris-EDTA buffer

**TH:** Total Hardness

**UPGMA:** Unweighted Pair Group Method with Arithmetic Mean

**w/v:** Weight by Volume

**WHO:** World Health Organization

**X-gal:** 5-Bromo-4-Chloro-3-Indolyl-beta-D-Galactopyranoside

**μS/cm:** Micro Siemens by Centimeter

**GENERAL**

**INTRODUCTION**

## GENERAL INTRODUCTION

From an anthropocentric point of view, hostile environments to man are designed as extreme. Hot springs, geysers, deep-sea hydrothermal vents, cold arctic water, acidic and alkaline water, saturated salt brines, hypersaline environments, evaporates, deserts, and pressurized abyssal fluids were once thought to be too extreme to host microbial life at all. Microorganisms thriving within such environments are designated as 'extremophiles' (Stetter, 1999).

Extreme environments are challenging for most life forms due to their physical extremes (e.g., temperature, radiation, or pressure) and geochemical extremes (e.g., desiccation, salinity, pH, redox potential). Depending on their optimal growth conditions, bacteria have been named thermophiles, psychrophiles, acidophiles, alkaliphiles, halophiles, and barophiles (Capece *et al.*, 2013).

In the last decade, the investigations on extreme environments and their inhabiting organisms have been considered key clues to studying life's evolution on the early Earth or even extraterrestrial life, thus drawing worldwide attention. The discovery of life in extreme environments has searched for extraterrestrial life more plausible. Scientists detected traces of methane on Mars, which some believe is a by-product of extremophilic methanogens (Maus *et al.*, 2020).

The discovery of fossil remains of thread-like microorganisms in a 3.2-billion-year-old deep-sea volcanogenic hydrothermal massive sulfide deposit from the Pilbara Craton of Australia indicates the existence of hyperthermophiles already at Early Archaean times (Rasmussen, 2000). Further, based on their growth requirements, hyperthermophiles could already exist on the early Earth about 3.9 Gyr ago (Stetter, 2006a).

Over the first 200 million years, temperatures on the Earth's surface were thought to be higher than 100 °C, making liquid water collection impossible. When the temperatures dropped, microbial life emerged, but the environmental conditions remained high (Djokic *et al.*, 2017). As a result, the first organisms to evolve were most certainly thermophiles or at least thermotolerants (Stan-Lotter, 2017). The universal phylogenetic tree based on the small subunit

of the 16S rRNA gene, which places the thermophile branches close to the tree's root, supports this hypothesis (Stetter, 2006a).

On Earth nowadays, temperatures above 55°C are uncommon and are intimately associated with geothermal habitats. As a result, a "thermophile boundary" of 55–60 °C was established, above which thermophiles grow.

The word "thermophile" has been derived from two Greek words, "thermotita" (meaning heat) and "philia" (meaning love). Thermophiles are heat-loving organisms that tolerate high temperatures and usually require these for their growth and survival. Growth temperatures range from 50°C to as high as 122°C, currently recognized as the upper temperature limit for life (Mehta and Satyanarayana, 2013).

These microorganisms have been classified into moderate thermophiles (45-65°C), extreme thermophiles (65-80°C), and hyperthermophiles (>80°C) (Kumar *et al.*, 2019). Thermophilic and hyperthermophilic bacteria are distinguished by optimal growth temperatures of 60 and 80 °C, respectively, with temperatures exceeding 121°C being recorded by *Methanopyrus kandleri* isolated from the deep ocean near Japan, this strain is the most thermophilic organism known (Takai *et al.*, 2008). The upper-temperature limit for eukaryotic microorganisms is even lower, approximately 60–62°C, at which only a few species of thermophilic fungi can grow. The upper-temperature limits for eukaryotic algae and protozoa are slightly lower (55–60°C) (Eswari *et al.*, 2019).

Thermophilic prokaryotes have been known for over 100 years, while hyperthermophilic prokaryotes were discovered only four decades ago. In 1966, Thomas Brock was the first researcher who elucidated the existence of living microorganisms in the boiling hot springs of Yellowstone National Park in the USA, and in 1969, he isolated and described the first thermophilic bacteria from Yellowstone; *Thermus aquaticus* providing the first impetus for detailed studies on the physiology of thermophilic bacteria (Gómez, 2011).

However, the first hyperthermophiles isolated and characterized in the laboratory were *Methanothermus fervidus* and the *Thermoproteus* spp. isolated in 1981 from Icelandic hot springs by Karl O. Stetter and Wolfram Zillig, respectively, both strains exhibited growth temperatures up to 97°C (Stetter *et al.*, 1981; Zillig *et al.*, 1981). The subsequent work by Zillig and Stetter, among others, and improvements in submersibles and isolation methods allowed the identification of hyperthermophiles able to grow above 110°C (Stetter, 2006b). Since Brock's discovery, thermophiles have been fined out in geothermal features worldwide, including

areas in Iceland, Kamchatka, New Zealand, Italy, and other locations (Tobler and Benning, 2011; Gugliandolo *et al.*, 2015; Merkel *et al.*, 2017).

The discovery of deep-sea hydrothermal vents in 1977 led to the first study of an ecosystem based on the primary production of chemosynthetic extreme and hyperthermophilic bacteria. Mostly the hyperthermophilic microorganisms are archaea, and most of them undertake standard metabolic processes such as methanogenesis, anaerobic respiration via sulfate reduction, sulfur reduction, nitrate reduction, iron reduction, aerobic respiration, or even fermentation (Kumar and Satyanarayana, 2013).

Thermophiles are, for the most part, prokaryotic eubacteria except for the two bacterial families (*Aquificaceae* and *Thermotogaceae*), which are categorized as hyperthermophiles, while the most hyperthermophilic are *Archaea*, which possess a large number of high-temperature adaptations (Urbieta *et al.*, 2015). In hot spring water, high temperatures accelerate the denaturation of biomolecules and increase the solubility of gases. In order to overcome these conditions, thermophiles have made physiological adaptation that allows the colonization and development at high temperature (Wang, 2021).

Thermophiles are recognized by the high thermostability of their proteins, which are constituent mainly of shorter amino acid lengths which may reflect the importance of a reduced number of flexible regions in the native protein structures (Urbieta *et al.*, 2015). Indeed, an increased number of charged and hydrophobic amino acids, higher the numbers of disulfide bonds in thermophilic intracellular proteins (Mehta *et al.*, 2016). Production of DNA-binding proteins, activation of heat shock proteins (*HSPs*), activation of reactive oxygen species, and efficient repair damage are adaptations in physiological systems and genetics as a stress response to stabilize homeostasis (Mohamad, 2018). Reverse gyrase (RG) is the only protein found ubiquitously in hyperthermophilic archaea and extremely thermophilic bacteria but absent from mesophiles. The RG display positive supercoiling activity, which was suggested to play a role in genome thermostability (Catchpole and Forterre, 2019).

Furthermore, high temperatures affect membrane fluidity. Thermophiles change the lipid content of membranes to preserve them in a liquid crystalline phase and regulate membrane potential, permeability, and function. They have more saturated fatty acids than mesophiles or psychrophiles, resulting in a higher hydrophobicity, which helps stabilize membranes at higher temperatures (Siliakus *et al.*, 2017). Furthermore, DNA and protein structure can be maintained at high temperatures by accumulating numerous substances, including compatible solutes such

as; trehalose,  $\alpha$  glutamate, proline, di-*myo*-inositol phosphate, and mannosylglycerate (Santos *et al.*, 2008).

Considering the genome size, the thermophiles have less intergenic DNA region and thus more small and compact genomes. On average, every 1 kb of a bacterial genome encodes a gene, but the length is slightly shorter in thermophilic *Archaea*. Mostly, bacteria growing below 45°C have genomes larger than 6Mbp, whereas thermophiles have genomes size less than 4Mbp (Sabath *et al.*, 2013). The GC content of rRNA/tRNA may be a better indicator of thermophilicity and thermostability due to the higher stability of the three hydrogen bonds between the GC base pair than the A-T pair with only two (Hu *et al.*, 2021).

Thermophiles attracted the interest of scientists for two main reasons: they reveal insights into the origin of life (Merino *et al.*, 2019) and because they have significant contributions in the field of biotechnology ranging from agriculture to biomedicine and industry (Kumar *et al.*, 2019). The biotechnological applications of thermophiles can be divided between applications using pure and consortia cell cultures and those exploiting their macromolecules and metabolites (Urbieta *et al.*, 2015). As thermophiles thrive at higher temperatures, they possess distinctive, unique, and novel enzymes which making this class of microorganisms a valuable resource for biotechnological and industrial applications (Temsah *et al.*, 2018), mainly in biomass utilization, food processing, bioenergy, pharmaceutical, and environmental bioremediation (Kumar *et al.*, 2019).

Like many industrial processes that take place at elevated temperatures and in the presence of concentrations of detergents, alcohols, and organic solvents, thermo-stability and thermo-activity of these enzymes are of great interest. As a result, these enzymes serve as a research tool for industrial biotransformation activities that endure harsh environments (Bhandari and Nailwal, 2020). Some prominent commercial enzymes are protease, cellulase, gelatinase, amylase, xylanase, laccase, pectinase, pullulanase, and chitinase (Mohamad, 2018). However, for the successful exploitation of extremophiles and their enzymes, several problems need to be resolved. These include developing efficient cloning and expression systems and improved cultivation techniques, especially for hyperthermophilic *Archaea* (Antranikian, 2008).

Furthermore, thermophiles have great application in bioenergy, biomining (Bhandiwad *et al.*, 2014), heavy metals recovery (Ilyas *et al.*, 2014), biodegradation of petroleum hydrocarbons (Rajkumari *et al.*, 2019), remediation of textile dyes, production of biosurfactant

(Mehetre *et al.*, 2019), exopolysaccharide (Wang *et al.*, 2019), and antimicrobial (Mahajan and Balachandran, 2017).

Two different approaches can be used to investigate the microbial ecology of geothermal environments. One approach is culture-dependent, which involves growing and isolating bacteria into pure culture. The other is culture-independent, which relies on PCR-based methods to identify the bacteria by amplifying the 16S rRNA gene.

For a long time, culture-dependent techniques were used in early investigations for the characterization of microbial communities. It is possible to study the microbial flora present in a complex environment by proceeding to enrichment and isolation steps on ordinary and specific culture media adapted for a given microorganism (cultivable) according to the physical and nutritional conditions. The main advantage of this approach is to isolate specific strains to perform more characterization studies on pure culture (phenotypic and physiological characteristics, synthesis capacities, etc.). Thus, most of our knowledge about microorganisms comes from studies performed on pure cultures isolated from different environments (Fry, 2004; Menasria, 2020). However, the cultivation-based analyses are insufficient to investigate the microbial diversity since they do not reveal a clear picture of the community diversity. Moreover, approximately 99% of the microorganisms present in nature cannot be cultured under laboratory conditions (Kikani *et al.*, 2017).

As a result, a comprehensive understanding of microbial diversity and phylogeny involves the assessment of culture-independent diversity. The first 16S libraries approach of thermophilic habitats was reported in 1994 by Barns *et al.* who explored the bacterial diversity in the Black Pool hot spring in Yellowstone National Park (de Souza and Rosado, 2018).

Earlier in the history of molecular microbial ecology, culture-independent approaches involving 18S or 16S rRNA gene sequencing offered a more comprehensive method to biodiversity analysis. Nearly complete 16S rRNA genes from bulk genomic DNA are amplified, cloned into cloning vectors, and transformed into suitable cloning hosts followed by recombinant clones differentiation by fingerprinting methods such as restriction fragment length polymorphism (RFLP) analysis, denaturing gradient gel electrophoresis (DGGE), or sequencing by the Sanger methodology (Urbieta *et al.*, 2015).

With the advancement of next-generation sequencing (NGS) reported for the first time in 2005, metagenomic analysis has become a more robust technology that allows for the creation of enormous numbers of sequences and better coverage of microbial communities from various

environments. The NGS uses parallel amplification, and sequencing yields shorter read lengths, giving an average raw error rate of 1%–1.5% (Hari, 2018).

The major NGS technology platforms for whole-genome sequencing are primarily from brand names such as Illumina, Roche 454, Solid, and Ion Torrent. Each platform has its advantages, disadvantages, and cost implications regarding reliability, time, and money.

Our knowledge of the phylogenetic and taxonomic biogeography of microbial communities from various ecologies has risen steadily. Nevertheless, there are still some gaps in our understanding of functional capabilities across biomes (Johnson *et al.*, 2017). Functional metagenomics is discussed as an emerging molecular technique with potential applications in industrial applications (Coughlan *et al.*, 2015).

Uncultured microorganisms' metagenomes are a rich source of novel enzyme genes. The methods for screening metagenomic libraries are divided into two groups based on the sequence or function of the enzymes. The sequence-based approaches rely on the known sequences of the target gene families. In contrast, the function-based strategies do not involve incorporating metagenomic sequencing data and, therefore, may lead to discovering novel gene sequences with desired functions (Rodgers and Zhang, 2019).

Algeria comprises approximately 240 hot springs, making it one of the world's richest geothermal zones. The northeastern part of Algeria is geothermally very interesting since most of these thermal resources are found in this part of the country, with temperatures ranging from 22 to 98°C (Saibi, 2009). The highest spring temperatures recorded were 68 °C for the Western area (Hammam Bouhnifia), 80 °C for the central part (Hammam El Biban), and 98 °C for the Eastern region (Hammam Debagh) in Northern Algeria, around one-third of hot springs temperatures are superior to 45 °C (Stambouli *et al.*, 2012). Algeria harbored Hammam Debagh, the second hottest thermal spring in the world and the hottest one in the country, with temperatures rising to 98°C (Stambouli *et al.*, 2012; Boukhenfouf and Boucenna, 2019).

However, these original and diverse habitats are still poorly studied to assess their biological resources, especially in terms of microbial diversity, only very limited informations are available on the indigenous microbiota (Amarouche-Yala *et al.*, 2015; Arab *et al.*, 2018; Gomri *et al.*, 2018; Benammar *et al.*, 2020).

This thesis is written as separate chapters; each is presented and discussed similarly as a scientific article written in IMRAD form. The first chapter has already been published, and the second is under review. In each chapter, the problem statement has been treated and discussed

independently. Each chapter includes a specific introduction, a materials and methods part, the results and discussion section, and a conclusion. Several bibliographic references are in common between the two chapters; a single reference list was established at the end of the thesis to avoid repetitions.

Below, a brief overview of each chapter is given:

- **CHAPTER I.** The first part of the thesis consists of evaluating eubacterial diversity in a culture-dependent or cultivable method. For this purpose, the strains were isolated on different culture media from water and sediment samples of terrestrial thermal springs from several localities in Northeastern Algeria. The sites were distributed over four cities (Batna, Biskra, Guelma, and Khenchela). The isolates were then identified using the conventional methods and SDS-PAGE fingerprinting of whole-cell proteins. Phylogenetic diversity was determined by sequencing the DNA encoding 16S rRNA. In addition, preliminary biotechnological tests have been carried out to demonstrate their potential as a source of extracellular hydrolytic enzymes.

- **CHAPTER II.** The second part of this thesis mainly focused on the estimation of Eubacterial and Archean diversity of Hammam Debagh (Guelma) and Hammam Saïda (Batna) in a culture-independent manner by a metagenomic approach using the next-generation sequencing (Illumina, MiSeq) to establish an accurate inventory of the diversity present in this environment. For this purpose, DNA extractions were performed on samples of shallow hot springs water and sediments to be sequenced at high throughput. The analysis of the effect of physicochemical characteristics of the water on the composition and abundance of prokaryotic communities sequestered within both hot springs. Thus, to establish a model of knowledge of the autochthonous thermophilic/thermotolerant communities of the Algerian hydrothermal springs and contribute to the excellent understanding of the resistance mode of these microorganisms to extreme conditions.

- The last part is a general conclusion, which describes the work that has been completed and future work that will provide a more comprehensive overview of the microbial communities at Algerian hot springs.

# CHAPTER I

*Culturable Thermophilic Bacteria  
and their Enzymatic Potential from  
Algerian Hot Springs*

# INTRODUCTION

## INTRODUCTION

Thermophiles are a group of heat-loving microbes thriving at high temperatures. They are grouped according to their optimum growth temperature as moderate thermophiles (50-60°C), extreme thermophiles (60-80°C), and hyperthermophiles (>80°C) (Kumar *et al.*, 2019). They inhabit various environments such as deep-sea hydrothermal vents, terrestrial hot springs, and other extreme sites, including volcanic regions, tectonically active faults, and decaying matters like the compost and deep organic landfills (Panda *et al.*, 2018).

The geothermal springs are considered unique hot spots for large communities of thermophilic microorganisms, mainly belonging to *Bacteria* and *Archaea* domains (Yohandini, 2015; Sahay *et al.*, 2017). Thermophile biodiversity can provide an overview of various potentials that can be utilized for many purposes. Such studies are required to understand the microbial community's organization, composition, and novel taxa further discovery (Najar *et al.*, 2018a; Li and Ma, 2019).

Thermophilic bacteria have attracted great attention due to their significant biotechnological interest; they are sources of different biomolecules (exopolysaccharide, antimicrobial, biosurfactant) (Mahajan and Balachandran, 2017; Mehetre *et al.*, 2019; Wang *et al.*, 2019) and thermostable enzymes such as amylases, cellulases, chitinases, pectinases, xylanases, proteases, lipases, and DNA polymerases for biotechnological applications in medical, industrial and agriculture process (Kumar *et al.*, 2019; Temsaah *et al.*, 2019). Thermophiles may also serve in an increasing number of potential bioremediation applications, mainly in the removal of heavy metals from waste (Özdemir *et al.*, 2013; Ilyas *et al.*, 2014), biodegradation of petroleum hydrocarbons (Rajkumari *et al.*, 2019), and may be used in the production of renewable energy (Bhandiwad *et al.*, 2014; Urbietta *et al.*, 2015).

Microbial studies about hot springs have been extensively reported in many countries, notably Yellowstone National Park (USA) (Inskeep *et al.*, 2013; Stone *et al.*, 2018), New Zealand (Power *et al.*, 2018), India (Mangrola *et al.*, 2015; Narsing Rao *et al.*, 2018), Russia (Tikhonova and Kravchenko, 2019; Wilkins *et al.*, 2019) Japan (Masaki *et al.*, 2016; Ward *et al.*, 2017), China (Liu *et al.*, 2016; Tang *et al.*, 2018), Iceland (Mirete *et al.*, 2011; Tobler and Benning, 2011) and Turkey (Inan *et al.*, 2016; Baltaci *et al.*, 2017).

Algeria is one of the world's richest countries in geothermal regions by containing over 240 hot springs; most of these thermal resources are located in the northeastern part of the

country, with temperatures ranging between 22 and 98°C (Saibi, 2009). Moreover, it hosts Hammam Debagh, also named Hammam Challala, with temperatures rising to 98°C, the hottest terrestrial spring in this country (Stambouli *et al.*, 2012), and the second in the world after those of Iceland (Boukhenfouf and Boucenna, 2019). Algerian hot springs were formerly only used as spas for balneology regarding their therapeutic effects (Fekraoui and Kedaid, 2005; Liang *et al.*, 2015). At these spots, researchers were mainly interested in geothermal potential, physicochemical composition, bacteriological and fungal contamination investigations to ensure the safety of users (Amarouche-Yala *et al.*, 2015; Benammar *et al.*, 2017; Ait Ouali *et al.*, 2019).

Despite intensive studies on terrestrial thermal springs worldwide, very little is known about the microbial biodiversity of hydrothermal springs in Algeria. Though recently, some studies on thermophilic bacteria have emerged, which stay limited only to some hot springs and aspects (Amarouche-Yala *et al.*, 2015; Arab *et al.*, 2018; Gomri *et al.*, 2018).

The identification of thermophilic species is usually performed by 16S rRNA sequencing, DNA-DNA hybridization, PCR-RFLP profiles, and BOX-PCR (Kuisene *et al.*, 2002; Aanniz *et al.*, 2015; Yohandini, Julinar, and Muharni 2015; Ming *et al.*, 2017). Nevertheless, multiple colonies are detected simultaneously during isolation and often with very close morphologies within and between the strains, making selecting different bacteria difficult. Consequently, an efficient technique for species recognition is required before further identification by molecular approaches.

The analysis of SDS-PAGE whole-cell protein patterns has proven to be highly effective and reliable for comparing and clustering many mesophilic bacteria belonging to different genera (Eribe and Olsen, 2002; Kim *et al.*, 2010; Santos *et al.*, 2012). Despite the scarcity of research studies about applying this technique on thermophilic species, it has proven its effectiveness on the differentiation of some thermophilic species before further identification by genomics tools. Our study is first attempts to classify and cluster the thermophilic bacteria isolated from Algerian terrestrial hot springs using SDS-PAGE profiling.

In the first chapter, we investigated the culturable thermophilic bacterial diversity using a culture-dependent approach. For this, colonies were isolated on different culture media from water and sediment samples belonging to eight hot springs distributed over four cities in Northeastern Algeria. Isolates were then identified, and phylogenetic diversity was determined based on SDS-PAGE whole-cell protein patterns clustering succeeded by 16S rRNA gene sequencing. The work was extended to investigate some industrial important hydrolytic

enzymes: amylase, cellulase, pectinase, esculinase, protease, gelatinase, lipase, lecithinase, and DNase from isolated thermophilic strains to evaluate their potential application in biotechnological processes.

This first chapter is structured in four parts:

- The introduction reports the knowledge acquired on the microbial communities colonizing hydrothermal environments and the potential applications of thermophiles, including the objectives underlying this chapter,
- The second part refers to all the analytical methods used to describe and characterize the sampled ecosystems from a microbiological point of view (isolation and identification of the thermophilic culturable bacterial flora and their thermozyms),
- The third part relates to the results and discussion of distribution, isolation, and phylogenetic identification of thermophilic eubacteria and their biotechnological potential as producers of enzymes,
- The fourth part is a conclusion, which describes the work that has been completed and future work that will provide a more comprehensive overview of the microbial communities of the hot springs in Algeria.

# CHAPTER I

## *Materials and Methods*

## 1. Site description

The sampling sites were distributed over different geographical areas in the North-East of Algeria to target diversified thermal springs. These sites represent varied habitats from a climatological, geographical, and physicochemical point of view, which is likely to predict a large thermophilic bacterial diversity.

The sampling study was carried out in eight terrestrial geothermal springs distributed over four cities (Batna, Biskra, Guelma, and Khenchela) in Northeastern Algeria; sites are described in (Tab.1, Fig.1, Fig. 2). Among the hot springs studied, six sites have never been explored for microbial biodiversity: Belhachani hot spring (H24A); Guerfa hot spring (H24G); Saïda hot spring (H05S); Guerdjima hot spring (H05G); Sidi El Hadj hot spring (H07S); and El Knif hot spring (H40K). The GPS (GARMIN 72H) was used to determine the geographical coordinates of the different hot springs.

**Table 1.** Geographic details of sampling sites.

Wilaya (city)	Hot spring name	Hot spring code	GPS location	Daïra (Municipality)
Batna	Saïda	H05S	35°34'03''N 5°33'46''E	N'gaous
	Guerdjima	H05G	35° 33'46" N 05° 32' 37"E	Ras El Aioun
Biskra	Sidi El Hadj	H07S	35°05'59'' N 5°37'00''E	El Outaya
Kenchela	Essalihine	H40S	35°26' 17''N 7°05'10''E	El Hamma
	El Knif	H40K	35°29'12'' N 7°15'10''E	Baghai
Guelma	Debagh	H24D	36° 27'34 " N 7°16'10"E	Debagh
	Belhachani	H24A	36°23'49"N 7°33'76"E	Ain Larbi
	Guerfa	H24G	36°24'70"N 7°34'01" E	Ain Larbi

- **Hammm Saïda:** located in N'gaous, about 80km west of Batna. This source has been exploited since 2015 for the creation of a Spa. The spring water temperature reaches 63°C with a flow rate of 18 l/s (MTATF, 2015).
- **Hammam Guerdjima:** located in Gosbat, Daïra of Ras El Aioun at about 61Km Northwest of the city of Batna. This source is still under-exploited due to the lack of promotion and investment; its capacity, as well as its potentialities of use, remain very insufficient to date. The predominant facies is sodium chlorinated with a temperature of 41.6 °C and an operating flow rate of 2 l/s (Athamena *et al.*, 2015)

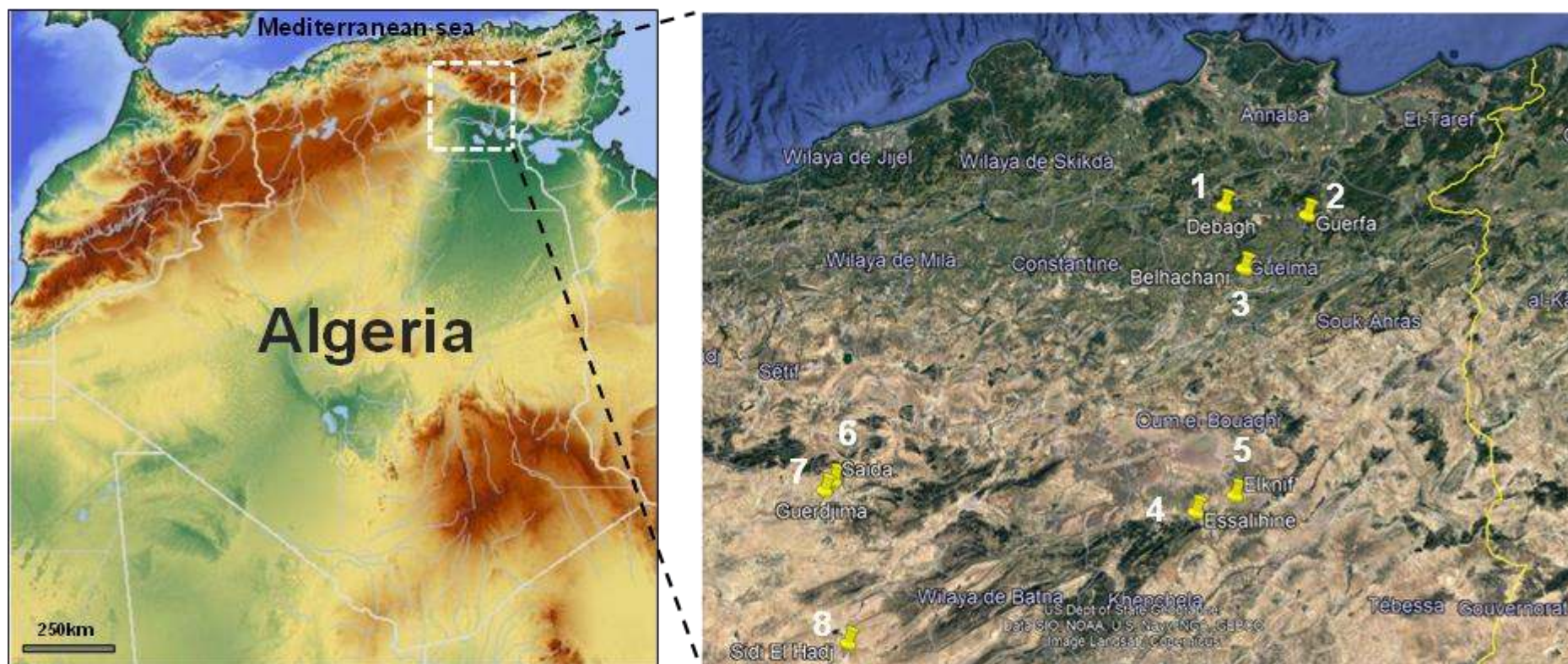

**Figure 1.** Location map of the sampled sites (North-East Algeria). **1.** Debagh hot spring (**H24D**), **2.** Guerfa hot spring (**H24G**), **3.** Belhachani hot spring (**H24A**) **4.** Essalihine hot spring (**H40S**) **5.** El Knif hot spring (**H40K**), **6.** Saïda hot spring (**H05S**) **7.** Guerdjima hot spring (**H05G**), **8.** Sidi El Hadj hot spring (Google Earth Pro v7.3.2, Accessed March 2021).

- **Hammam Sidi El Hadj:** located 25 km North-West of Biskra in the Daïra of El-Outay, and 98Km from Batna. Also called Hammam Bordj Rose is an abandoned heritage; discovered two centuries ago with a temperature of 42°C. Unfortunately, this source is underexploited, except for a very long-standing building with traditional exploitation, which requires action to modernize the infrastructure. Sodium chloride and calcium chloride are predominant in the water spring (MTATF, 2015; Boufassa, 2018).
- **Hammam Essalihine:** is a Roman bath that has existed for 2,000 years. It is located in the commune of El Hamma, 7 km from Khenchela. Its exploitation dates back to Roman times and up till now. It includes a thermal station accompanied by a hotel with an annual capacity of nearly 700,000 people. Chemical facies revealed calcic chloride water with a temperature of 70°C and a flow rate of 5 l/s (Bahri *et al.*, 2011; Stambouli *et al.*, 2012).
- **Hammam El Knif:** a unique source of natural sulfurous vapors in Algeria. It is located about 14 km from Khenchela City. This hot spring hosted a project to construct a touristic thermal spa to exploit spring water, which reaches a temperature of 52°C. A calcic chloride facies is predominant in the water spring (Amarouche-Yala *et al.*, 2015).
- **Hammam Debagh:** also called Hammam Meskhoutine, a thermal spa located 15 km from the city of Guelma in North-Eastern Algeria. It is the only source in the country which counts nine fountains classified as hyperthermal, with a temperature ranging between 72°C and 98°C allowed the site to rank as the hottest hot spring in Algeria. For most fountains, the spring water was calcium bicarbonate or sodium chlorinated, with a high flow rate of 80 to 100 l/s (Ouali, 2015; Boukhenfouf and Boucenna, 2019).
- **Hammam Belhachani:** located in a "Mechta" at 10 Km from Ain Larbi and at 32Km South of Guelma City. In 2015, this source benefited from the official launch of the construction of a thermal spa. Calcium sulfate facies designates the chemical character of the water spring with a temperature of 72°C and a flow rate of 0.5 l/s (Bekkouche, 2016).
- **Hammam Guerfa:** is used as a small spa, with a temperature of 62 °C and a flow rate of 1.1 l/s, located in Ain Larbi at 32 Km South of Guelma City, on the way to Aïn Mekhlouf. A calcium sulfate facies is predominant in the water spring (Bekkouche, 2016).

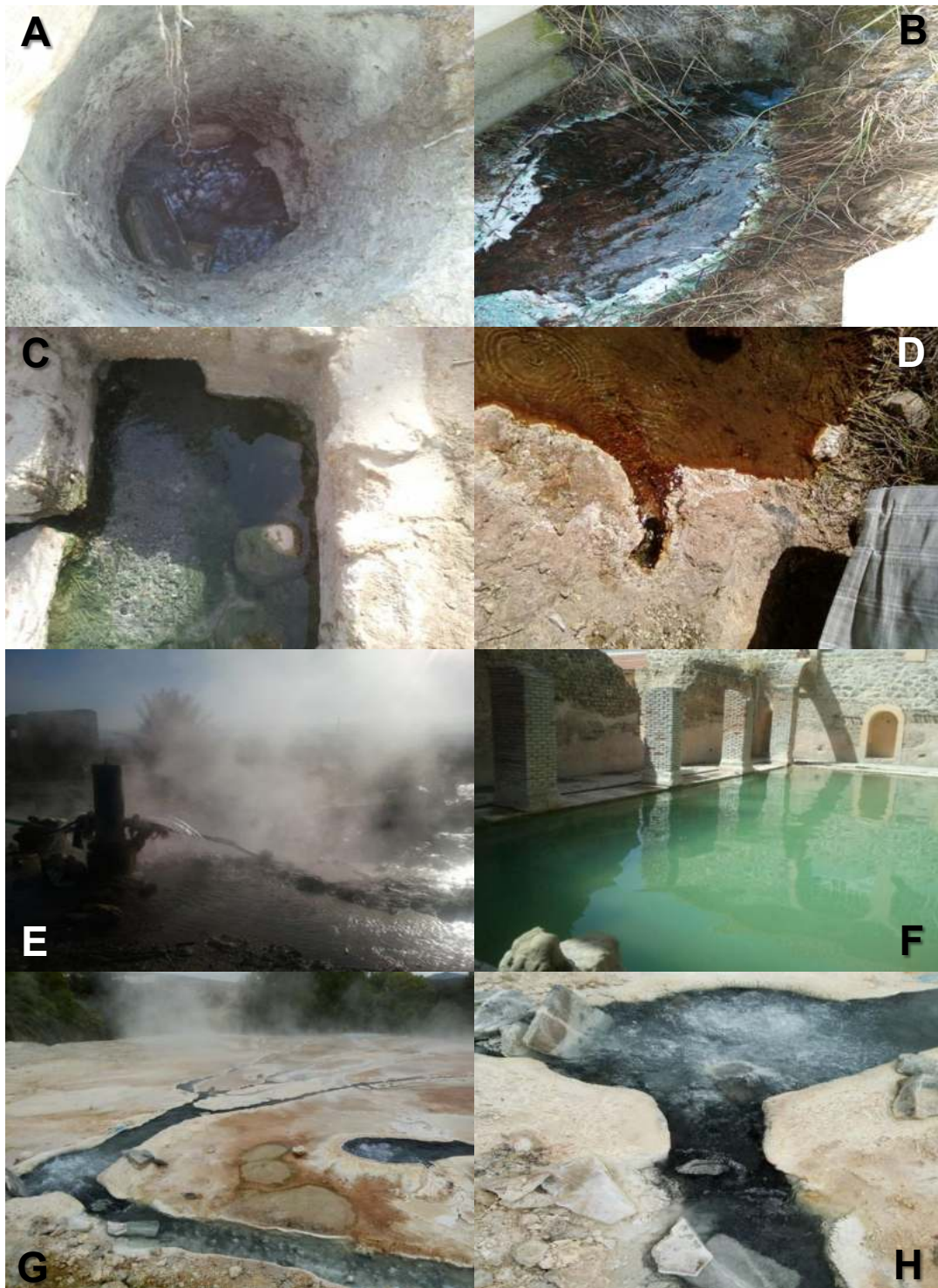

**Figure 2.** The different prospected hot springs. **A.** Guerdjima hot spring (H05G), **B.** Guerfa hot spring (H24G), **C.** Sidi El Hadj hot spring (H07S), **D.** Belhachani hot spring (H24A), **E.** Saïda hot spring (H05S), **F.** Essalihine (H40S) **G.** and **H.** Debagh hot spring (H24D).

## 2. Sample collection

Forty water and sediment samples were collected from August 2015 to August 2017 from the eight targeted hydrothermal springs for microbiological studies (Tab.2). Additional samples were collected for physicochemical analyses. They were collected in new borosilicate glass bottles with Teflon caps treated with 1/10 diluted nitric acid and rinsed with distilled water (Rodier *et al.*, 2016).

**Table 2.** Date and nature of samples from each thermal spring.

Hot spring	Sampling date	Type of samples
Saïda (H05S)	01/01/2016	Water + Sediment
Guerdjima (H05G)	01/01/2016	Water + Sediment
Sidi El Hadj (H07S)	04/09/2015	Water + Sediment
Essalihine (H40S)	05/08/2015	Water + Sediment
El Knif (H40K)	05/08/2015	Water (*)
Debagh (H24D)	11/08/2017	Water + Sediment
Belhachani (H24A)	11/08/2017	Water + Sediment
Guerfa (H24G)	11/08/2017	Water + Sediment

(\*): the depth was great enough to prevent the sediment sampling (more than 140m).

### 2.1. Water sampling

The water samples from each sampling point at a depth of 30–50 cm from the surface were collected aseptically in sterile borosilicate glass containers of 250 ml. The samples were taken manually by holding the vials with metal crucible tongs due to the high temperature of the water. When the bottles were filled (no bubbles came out), they were remounted and finally plugged with their caps immediately.

### 2.2. Sediment sampling

The sediment was recovered with a long sterile spatula from the bottom of the spring and then deposited in sterile polypropylene sampling pots, following the same indications previously mentioned for water sampling (Rodier *et al.*, 2016).

The water and sediment samples were carefully labeled, then stored, and immediately transported on ice to the laboratory for further analysis. Microbiological analysis was carried out on the same day of sampling.

### 3. Physicochemical analysis

For water, physicochemical parameters such as temperature, pH, and conductivity were recorded *in situ* by a portable multiparameter meter (Hanna HI 8314) and a portable conductivity meter (Hanna HI-8733).

The sediment was air-dried, then sieved with a 2 mm mesh sieve to uniform particle size, and removed the coarser fractions (pebbles, debris, etc.). 20 g of dry sediment was added into 50 ml of water, stirred for 2 min. The mixture was allowed to settle for at least 30 min (Rodier *et al.*, 2016). The pH and conductivity were measured from the supernatant using a benchtop pH meter (WTW pH 325) and conductivity bench meter (Hanna HI 2315).

### 4. Isolation of thermophilic bacteria

For the isolation of the culturable thermophilic bacteria from the collected water and sediment samples, two techniques were used; (i) liquid enrichment and (ii) dilution plating, on six different culture media (Appendix 1):

- Thermus medium (Brock and Freeze, 1969);
- Castenholz medium D and Thermus 162 medium (Degryse medium) (Degryse *et al.*, 1978),
- ATCC medium 697 (Thermus Thermophilus medium or TT medium) (Oshima and Imahori, 1974),
- Nutrient medium (Adiguzel *et al.*, 2009), and
- Tryptic soy medium (Arya *et al.*, 2015).

Solid media were obtained by adding 3% (w/v) Agar-Agar to liquid media and sterilized at 121°C for 20 min. The pH was adjusted to 7.0-7.5 using a solution of 2M NaOH.

#### 4.1. Dilution plating

##### 4.1.1. Sediment preparation

One gram of sediment was taken and suspended in a test tube containing 10 ml of sterile 0.85 % (w/v) saline solution. The samples were vortexed for 10 min.

##### 4.1.2. Serial dilution protocol

The water and suspended sediment samples were diluted five-fold ranging from  $10^{-1}$  to  $10^{-5}$ . After dilution, 100  $\mu$ l of each dilution sample was transferred onto six different bacterial media (above-mentioned), aseptically using a micropipette, and was spread through a sterile

glass spreader. The plates were incubated at 55°C for 2-10 days in plastic bags to prevent the drying of agar at this temperature.

#### **4.2. Liquid enrichment**

For the enrichment method, 10 g or 10 ml of sediment and water samples were transferred into 100 ml of appropriate broth media (above-mentioned). Incubation was performed in a rotary shaker at 55 °C until turbidity occurred. 1ml aliquots from each sample were transferred in 9 ml of 0.85 % saline water. Five-fold dilutions were prepared, then 100 µl of each dilution was plated on the appropriate solid media and incubated at 55 °C for one day to five days. The plates were covered with plastic bags (Skeh *et al.*, 2007).

#### **5. Purification and preservation**

The plates were monitored after 24 h and then constantly observed for up to 10 days for the appearance of bacterial colonies in the different employed media. Single colonies with distinct morphology were selected from each plate and purified by successive streaking on respective medium plates. Pure cultures were maintained at 4 °C as slant and in 20% glycerol stock at -80 °C for further use.

##### **5.1. Nomenclature of isolates**

Each isolate was named based on the thermal spring's code from which it was isolated, followed by the number of strains representing the strain isolation order; Saïda (**05S**), Guerdjima (**05G**), Sidi El Hadj (**07S**), Essalihine (**40S**), El Knif (**40K**), Debagh (**24D**), Belhachani (**24A**), and Guerfa (**24G**).

#### **6. Phenotypic features of isolates**

All phenotypic tests were made in duplicate and repeated when inconsistent results were observed. All growth tests, unless otherwise specified, were performed at 55 °C on *Thermus* media.

##### **6.1. Morphological characterization**

The colony morphology of the thermophilic isolates was checked by direct and stereomicroscopic observations of single colonies. Gram staining was carried out using the standard Gram's reaction (Murray *et al.*, 1994) and was confirmed by a non-staining procedure using the KOH lysis test method (Gregersen, 1978). Endospore forming determination was performed as described by the Schaeffer Fulton method (Schaeffer and Fulton, 1933).

## 6.2. Biochemical characterization

### 6.2.1. Catalase test

The isolates were grown on the Thermus medium for 24 h at 55°C. A few drops of 3% of hydrogen peroxide were added to colonies, the appearance of bubbles indicates a positive catalase activity (Maugeri *et al.*, 2001).

### 6.2.2. Oxidase test

Oxidase reaction was performed by touching and spreading a well-isolated colony on the oxidase disc (HiMedia), impregnated with N, N-dimethyl-p-phenylenediamine oxalate. The positive reaction indicated by the formation of blue-purple color must be observed within 5-10 sec at 25-30°C. A change later than 10 seconds or no change at all is considered a negative reaction (Skeh *et al.*, 2007).

### 6.2.3. API 20E test system

According to the manufacturer's instructions, with some modifications, the biochemical characteristics were screened by the API 20E® strips system (bioMérieux, France). The number of bacteria was adjusted to 1 McFarland standard, and 200µl of suspension was transferred into each well. Strips in incubation boxes were put into a plastic container filled into the bottom with sterilized water to minimize evaporation and then incubated at 55 °C.

The API strips were observed at 4, 8, 16, and 24 h. At each observation point, water was replenished when necessary (Khan *et al.*, 2018).

A similarity dendrogram among API20E profiles was constructed using the MEGA6 software based on the UPGMA method and Jaccard coefficient to clarify biochemical characters.

## 6.3. Physiological characterization

The temperature and pH range for growth was determined following incubation of the strains on Thermus agar at different temperatures (30-75 °C) and pH (4.0-9.0) with 5 °C and one interval, respectively. The pH was adjusted with three different buffers (final concentration of 10 mM): acetate buffer, pH 4-5.5; phosphate buffer, pH 5.8-8.0; Tris buffer, pH 7.1-9.0.

The halotolerance was assayed by plating each culture onto Thermus medium supplemented with 0, 2, 2.5, 5, 7.5, 10, 15, and 20% (w/v) NaCl. The growth was determined by visual observation after three days of incubation (Munster *et al.*, 1986).

## 7. SDS-PAGE of whole-cell proteins

### 7.1. Preparation of protein extracts

The thermophilic strains of 0.1 OD at 600 nm were incubated overnight at 55 °C in 50 ml of LB broth and centrifuged at 16,000 ×g for 10 min at 4 °C. Each sample pellet was washed twice with distilled sterile water and suspended in 100mM phosphate buffer (pH=7.6). The suspensions were then sonicated with an Ultrasonic homogenizer (LABSONIC M, Sartorius) at an output of 40% amplitude and pulse mode of 30sec with 10sec intermittence, for 3-5 min according to bacterial strains. To prevent heat buildup, sample tubes were placed in an ice bath during sonication. All lysates were clarified by centrifugation at 16,000 g for 15 min at 4 °C. The supernatant obtained was stored at -20°C (Belduz *et al.*, 2003).

### 7.2. Protein assay

The protein concentration of cell lysates was measured according to Bradford microplate protein quantification assay (Bradford, 1976; Ernst and Zor, 2010). The assay was performed with 10 µl of protein sample mixed with 200 µl of Bradford's reagent (Appendix 2). In each well, the microplates were then shaken with a microplate shaker (VWR 444-0270) for 1 min and incubated in the dark for 5 min at room temperature. The absorbance was measured at 595 nm with a microplate reader (SpectraMax® M2), and the protein concentration was determined from a standard curve using 1mg/ml bovine serum albumin (BSA) as standard protein (Appendix 4).

### 7.3. Sample preparation

The protein samples were then mixed with a Laemmli sample buffer (Appendix 2). For protein denaturation, samples were heated for 5 min at 95 °C, centrifuged at 12,000g for 5 min to prevent streaking during electrophoresis, and kept on ice before loading into the wells.

### 7.4. SDS-PAGE electrophoresis migration

The SDS-PAGE of whole-cell proteins was carried out as described by (Laemmli, 1970), on vertical slab gels (20x20 cm x 1 mm) in a Protean® II xi Cell gel electrophoresis apparatus (Bio-Rad Laboratories), using 12% (w/v) separating and 5% (w/v) stacking gels (Tab. 3), filled with the running buffer (Appendix 2). A volume of a sample containing 40–50 ng of protein was layered on top of the gel. Electrophoresis was performed at a constant current of 120 V through the stacking gel and 200V through the resolving gel for 4 h. The broad range protein

molecular mass marker (11 and 190 kDa, Prestained Protein Ladder, Biolabs) was used in each gel to determine the protein molecular mass.

### 7.5. Staining and drying of the gel

After electrophoresis, the gel was stained for 1 h with 200 ml of 0.1% (w/v) Coomassie Brilliant Blue R-250 (Sigma) (Appendix 2) with gentle continuous shaking. The gel was then destained firstly with 100 ml of 10% (v/v) acetic acid and 50% (v/v) methanol aqueous solution for 1h followed by a second destained solution containing 5% (v/v) methanol, 7% (v/v) acetic acid and 88% water overnight until clear bands corresponding to the proteins were visualized.

The gels can be stored for a few days in water or dried directly by heating under vacuum with the gel dryer; Gel Dryer Model 583 (Bio-Rad). The gels were then scanned, and the strips were analyzed using dedicated software.

**Table 3.** Composition of polyacrylamide-SDS gels used for the separation of proteins by SDS-PAGE.

Solutions	Separating Gel 12%	Stacking Gel 5%
Acrylamide Mix 30%	12 ml	830 $\mu$ l
Tris-HCl 1.5 M pH 8.8	7.5 ml	–
Tris-HCl 1.5 M pH 6.8	–	630 $\mu$ l
SDS 10% (p/v)	300 $\mu$ l	50 $\mu$ l
Ammonium persulfate 100 mg/ml	300 $\mu$ l	50 $\mu$ l
TEMED	12 $\mu$ l	5 $\mu$ l
H <sub>2</sub> O	9.9 ml	3.4 ml

### 7.6. Computing numerical data

The destained gels were scanned and stored as JPEG files. The whole-cell protein patterns were compared to each other to group the isolates belonging to every hot spring. The densitometric analysis, normalization, and interpolation of the protein profiles were performed using the BioNumerics version 7.6.3 software package (Applied Maths NV). The grouping of the bacterial strains by the Pearson product-moment correlation coefficient ( $r$ ) and cluster analysis on the matrix of correlation values was performed by the unweighted pair group method using arithmetic averages (UPGMA).

## 8. Molecular identification by 16S rRNA sequencing and phylogenetic analysis

### 8.1. Genomic DNA extraction

The bacterial genomic DNA of promising isolates was extracted using the Wizard® Genomic DNA Purification Kit by Promega (USA) according to the manufacturer's instructions (Fig. 3).

The bacterial cultures (1 ml) grown overnight at 55 °C in the Thermus broth were pelleted by centrifugation at 16,000×g for 2min. The supernatant was removed, and the cells were resuspended thoroughly in 480 µl of 50 mM EDTA, then 120 µl of 10 mg/ml lysozyme was added and gently pipetted to mix. This pretreatment aims to weaken the cell wall so that efficient cell lysis can take place. The samples were incubated for 1h at 37°C, after that, centrifuged for 2 min at 16,000× g to remove the supernatant.

The cells pellet was resuspended in 600 µl of nuclei lysis solution, mixed with gentle pipetting, and then incubated at 80 °C for 5 min. Cell suspension solution was cooled at room temperature, and 3 µl of RNase solution was added to the cell lysate and mixed properly by inverting tubes 2–5 times. The samples were then incubated for 1 h at 37 °C and cooled at room temperature before adding 200 µl of protein precipitation solution to the cell lysate. The tubes were vigorously vortexed at high speed for 20 secs and placed for 5 min on ice.

The precipitated proteins were then pelleted by 3 min centrifugation at 16,000×g. The supernatant containing DNA was transferred to a clean tube containing 600 µl of isopropanol. Samples were mixed gently by inversion until the DNA appeared as visible thread-like strands. DNA was then harvested by centrifugation at 16,000×g for 2min, and the supernatant was discarded. The pellet was then washed with room temperature 70% ethanol and harvested once more with the same conditions.

The supernatant was discarded, the pellet was allowed to dry before being resuspended in 100 µl of DNA rehydration solution and incubated for 1 h at 65 °C. The solution was periodically mixed by gentle tapping on the tube. Finally, the DNA was stored at 4°C (Promega, 2019).

### 8.2. Purity control and DNA concentration determination

The extracted DNA was stored in sterile Eppendorf microtubes at 4 °C. This DNA was checked by 1% agarose gel electrophoresis. The concentration and purity were determined by

measuring 2  $\mu$ l of DNA samples at Abs260/Abs280 and Abs260/Abs230 ratios using a NanoDrop 2000 spectrophotometer (Thermo Scientific).

A ratio A260/280 of 1.8 and 2.0 is generally accepted as pure DNA. A ratio of less than 1.8 indicates contamination with protein or phenol, and when it is greater than 2.0, the contamination is due to the presence of RNA. The ratio A260/230 should be between 2.0 and 2.2. A lower ratio than expected may indicate the presence of contaminants that absorb at 230 nm like chaotropic salts such as guanidine thiocyanate (GTC) and guanidine hydrochloride (GuHCl), EDTA, polysaccharides, and phenol (Matlock, 2015).

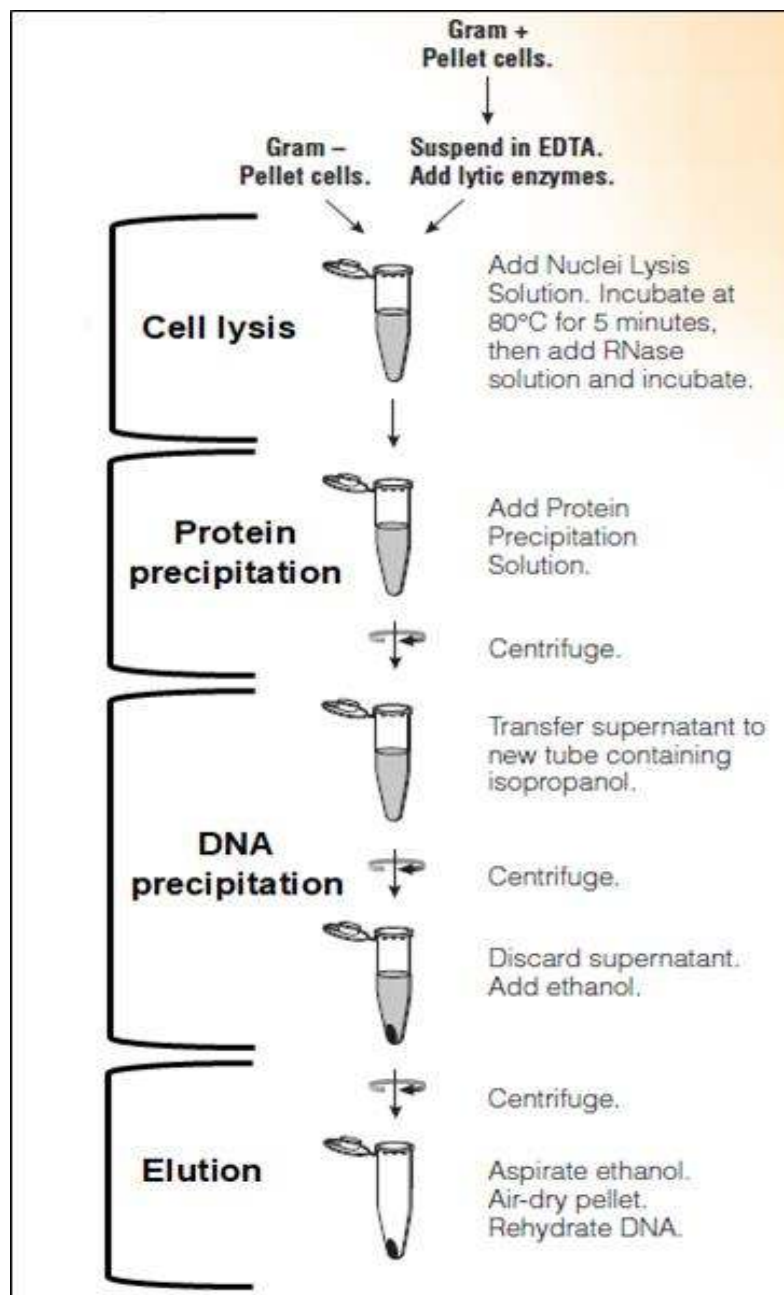

**Figure 3.** Cellular DNA extraction by the Wizard® Genomic DNA Purification Kit (Promega, 2019).

### 8.3. PCR amplification

The extracted DNA samples were used as a template for amplification of the near full-length sequences 16S rRNA gene using the universal primers UNI16S-L (5'-ATTCTAGAGTTTGATCATGGCTCA-3') corresponded to the positions from 11 to 26 of *Escherichia coli* 16S rRNA and UNI16S-R (5'-ATGGTACCGTGTGACGGGCGGTGTGTA-3') corresponded to all positions from 1,411 to 1,393 of *E. coli* 16S rRNA (Belduz *et al.*, 2003).

The PCR reactions were carried out in 50  $\mu$ l volume containing 10  $\mu$ l GoTaq Flexi Buffer (5X), 3  $\mu$ l MgCl<sub>2</sub> (25 mM), 1  $\mu$ l dNTPs (10 mM), 1  $\mu$ l reverse primer (10 mM), 1  $\mu$ l forward primer (10 mM), 0.25  $\mu$ l GoTaq G2 Flexi DNA polymerase (5 U/ $\mu$ l), 1  $\mu$ l of the DNA template, the volume was made up to 50  $\mu$ l with sterile Milli-Q water. Negative control was set; the reaction contains all PCR components except the template, which detects possible contamination.

The PCR amplification was conducted in a Thermocycler type (Biometra T personal) under conditions that consisted of initial denaturation at 95 °C for 2 min, followed by 35 cycles of denaturation at 94 °C for 1 min, annealing at 55 °C for 1 min, extension at 72 °C for 2 min, and a final polymerization step of 72 °C for 5 min.

### 8.4. Agarose gel electrophoresis

The PCR products' electrophoresis was carried out on a 1% agarose gel containing 0.5  $\mu$ g/ $\mu$ l ethidium bromide (EtBr) in a solution of TAE 1X to ensure the amplification's quality and specificity (Appendix 2). Electrophoresis was carried out in a horizontal Owl™ EasyCast™ B1A Mini Gel Electrophoresis Systems (Thermo Scientific™); the gel dimension was 7 cm x 8 cm.

The PCR products were added to a 6X DNA loading dye (Thermo Fisher Scientific). Migration was performed at 120 volts for 20 min. A GeneRuler 1Kb DNA Ladder marker (Thermo Scientific) that migrated parallel to the DNA under study was used as a size reference. The DNA fragments were visualized and photographed under UV by a Doc XR+ Molecular Imager Gel (BioRad) coupled to a CCD camera using the EtBr contained in the gel and which intercalates between the bases of the DNA molecule and allows the visualization.

### 8.5. Cloning of PCR products

To sequence the 16S rRNA PCR products, we opted for cloning in the pGEM-T Easy vector (Promega, USA).

The pGEM®-T Easy vector is a linearized vector with a single 3'-terminal thymidine at both ends. The T-overhangs at the insertion site significantly improve the ligation efficiency of PCR products by preventing recircularization of the vector and providing a compatible overhang for PCR products generated by specific thermostable polymerases. This vector contains T7 and SP6 RNA polymerase promoters (Fig. 4, Fig. 5) flanking a multiple cloning region within the  $\alpha$ -peptide coding region (*lacZ* gene) of the enzyme  $\beta$ -galactosidase and ampicillin resistance gene. Insertional inactivation of the  $\alpha$ -peptide allows recombinant clones to be directly identified by color screening (bleu/white) on plates.

The pGEM®-T Easy Vector contains multiple restriction sites within the multiple cloning regions. The multiple cloning regions are flanked by recognition sites for the restriction enzymes *EcoRI*, *BstZI*, and *NotI*, thus providing three single-enzyme digestions for the release of the insert. Forward and Reverse M13 primers frame the cloning cassette and allow amplification of the cloned DNA fragment to verify its insertion (Promega, 2018).

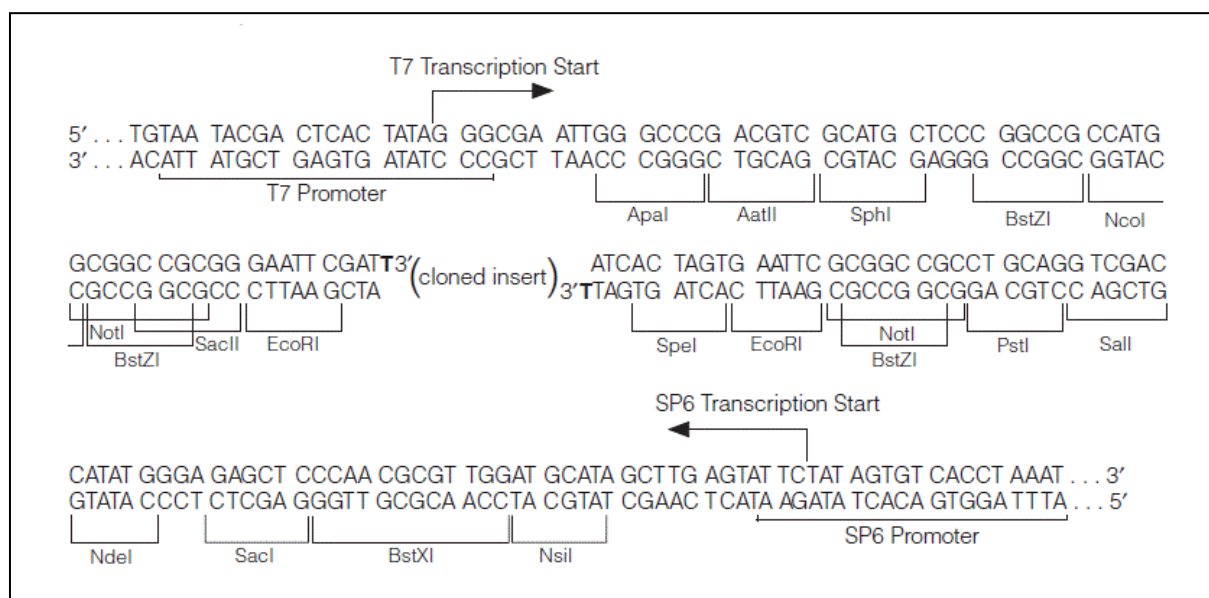

**Figure 4.** The promoter and multiple cloning sequence of the pGEM®-T Easy Vectors. (The top strand of the sequence shown corresponds to the RNA synthesized by T7 RNA polymerase. The bottom strand corresponds to the RNA synthesized by SP6 RNA polymerase) (Promega, 2018).

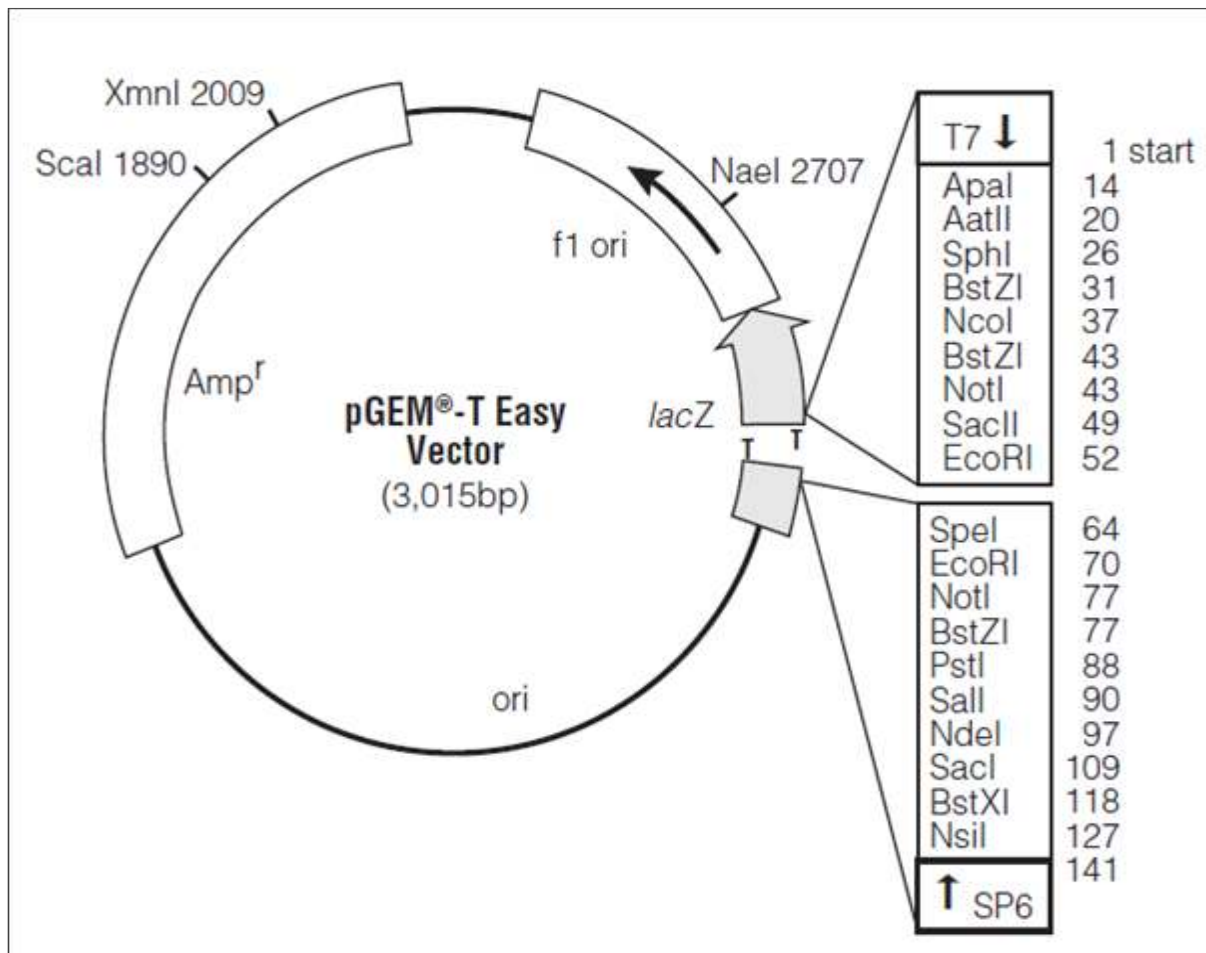

**Figure 5.** The pGEM®-T Easy Vector circle map and sequence reference points (Promega, 2018).

***pGEM®-T Easy Vector sequence reference points:***

T7 RNA polymerase transcription initiation site	1
Multiple cloning region	10–128
SP6 RNA polymerase promoter (–17 to +3)	139–158
SP6 RNA polymerase transcription initiation site	141
pUC/M13 Reverse Sequencing Primer binding site	176–197
LacZ start codon	180
Lac operator	200–216
β-lactamase coding region	1337–2197
Phage f1 region	2380–2835
Lac operon sequences	2836–2996, 166–395
pUC/M13 Forward Sequencing Primer binding site	2949–2972
T7 RNA polymerase promoter (–17 to +3)	2999–3

### 8.5.1. Preparation of competent cells

The bacterial strain *Escherichia coli* K12 JM101 *supE*, *thi*,  $\Delta(lac-proAB)$ , [*F'* *traD36*, *proAB*, *lacIqZAM15*] was used as a cloning host. The bacterium was made competent (transiently DNA permeable) by chemical treatment with CaCl<sub>2</sub>.

In *E. coli*, the state of competence was achieved by cold CaCl<sub>2</sub> chemical embrittlement of the membrane. This treatment would allow the formation of pores in the membrane and thus facilitate the entry of DNA into the bacterium (Sambrook *et al.*, 1989).

To accomplish this, *E. coli* JM101 was inoculated into LB broth and incubated at 37 °C for 16 h. An aliquot of the pre-culture was re-inoculated into 30 ml of the same medium to give an O.D.<sub>600nm</sub> of 0.1 and incubated at 37 °C with vigorous shaking at 180 rpm until the O.D.<sub>600nm</sub> reached 0.45-0.55, which is considered as the exponential phase of cells. When proper growth was achieved, the bacteria were recovered by refrigerated centrifuge (4°C) at 4500 g for 5 min. The pellet was then suspended in 10 ml of an ice-cold sterile 100 mM CaCl<sub>2</sub> solution and carefully stroking pellet with a fingernail. The cells were incubated for 30 min in the icebox. The pellet was recovered for the second time by refrigerated centrifuge (4°C) at 4500 g for 5 min and was resuspended in 2 ml of cold 100 mM CaCl<sub>2</sub> solution. The so-called competent cells are then ready for use after at least 2 h and not more than 48 h storage at 4°C (Das and Dash, 2015).

### 8.5.2. Ligation of PCR product

The PCR products to be cloned were inserted into the pGEM-T Easy vector (50 ng/μl, Promega) at a 1:3 molar ratio of vector: insert DNA (Tab 4.). Both were exposed to T4 DNA ligase (3U/μl Promega) and a ligation buffer (T4 DNA ligase buffer 10X Promega) in a final volume of 10μl. The solution was incubated overnight at 4°C.

The calculation of the insert was determined by the *Promega BioMath Calculators software* based on the following formula:

$$\text{ng of insert} = \frac{\text{ng of vector} \times \text{Kb size of insert}}{\text{Kb size of the vector}} \times \text{molar ratio of } \frac{\text{insert}}{\text{vector}}$$

**Table 4.** Ligation reaction mixture composition

Components	Volume (μl)
Sterile Milli-Q water	4
pGEM-T Easy vector (50 ng/μl) Promega	1
T4 DNA ligase (3U/μl) Promega	1
T4 DNA ligase Buffer (10X) Promega	1
PCR product	3

### 8.5.3. Transformation

The recombinant DNA molecules thus prepared in the previous step were introduced into a competent cell of *E. coli* JM101.

A 200 μl of competent cell suspensions were added to 200 μl of DNA of interest into sterile 1.5 ml Eppendorf. The mixture was placed on ice for 30 min incubation. Later, the entry of DNA was then stimulated by heat shock without any shaking; the mixture was heated for 2 min at 42 °C and then quickly transferred to the ice for a further 10 min. 200 μl of LB broth was then added to each reaction mixture, and Eppendorfs were incubated at 37 °C for 2 h with shaking at 150 rpm for expression of ampicillin resistance. Negative control was used following the same steps without the addition of recombinant DNA.

The suspensions were centrifuged 10 sec at 16,000g to decant the cells; 200 μl of the supernatant was removed and discarded. Then, the pellet was re-suspended with 200 μl of the remaining supernatant. Transformants were selected by inoculation of the previous mixture on LB-agar plates supplemented with 50 μg/ml of ampicillin and previously smeared with 40 μl IPTG (100 mM) and 40 μl X-Gal (40 mg/ml). The Petri dishes were then incubated at 37°C for 12-18 hours.

After incubation, two kinds of colonies developed, blue and white. An additional incubation of 2 h at 4 °C facilitates the white/blue screen. Calculations of white colonies only (the transformants) were then made to calculate the transformation efficiency (transformant/μg plasmid), which can be calculated as the number of colony-forming units (CFU) produced by 1 μg of DNA according to the following formula:

$$\text{Transformation efficiency} = \frac{\text{No. of transformants (colonies)} \times \text{Final volume at recovery (ml)}}{\mu\text{g of plasmid DNA} \times \text{Volume plated (ml)}}$$

To preserve the clones, the white colonies (transformants) were streaked on LB medium supplemented with 50 µg/ml of ampicillin and stored at -20°C.

#### 8.5.4. Verification of cloning

##### a. Plasmid isolation of transformed cell

To confirm the cloning of our insert, plasmid DNA was isolated by the alkaline lysis technique (Birnboim and Doly, 1979).

For each sample, five white colonies were selected and inoculated separately in 5ml of LB ampicillin broth (50 µg/ml) and incubated at 37 °C for 16 h at 180 rpm. 3 ml of the culture was then centrifuged for 3 min at 16,000g; the pellet obtained was suspended in 200 µl of solution I (Appendix 2). The bacteria were then lysed by adding 400 µl of solution II (SDS 1%, NaOH 0.2M), homogenized gently by turning the microtubes several times; until the cell suspension cleared and became viscous then incubated on ice for 5 min.

For each Eppendorf, 300 µl of a 7.5 M sodium acetate solution was added and then gently homogenized by turning the microtubes until a white precipitate appeared. The mixture was then incubated in the icebox for 10 min. After centrifugation for 15 min at 10,000g, the supernatant containing plasmid DNA was recovered and transferred to a new Eppendorf, precipitated by addition of 600µl isopropanol, and centrifugation for 15 min at 12,000g. The pellet was washed twice with ice-cold 70% (v/v) ethanol, centrifuged for 5 min at 10,000g, then dried at 37°C for 30 min, and finally re-suspended in 40 µl TE buffer containing RNase A at 50 µg/ml (Appendix 2).

The plasmid profiles were determined by horizontal electrophoresis on a 1% agarose gel containing 0.5 µg/µl ethidium bromide (EtBr) in a solution of TAE 1X (see section 7.4.). At the same time, the concentration and purity were evaluated by NanoDrop 2000 (Thermo Scientific).

##### b. Digestion of DNA with restriction enzyme

The presence of the cloned fragment was confirmed by digesting the clones with appropriate restriction endonucleases. The restriction enzyme EcoRI (12 U/µl, Promega) was used to digest previously isolated plasmids. EcoRI can recognize the base sequence 5' GAATTC 3'. This restriction enzyme cut each strand of DNA between the G and the A, which leaves "sticky ends" of DNA. Each single-stranded overhang has the sequence 5' AATT 3'. These overhanging ends will bond to a DNA fragment with a complementary sequence of bases (Fig. 6).

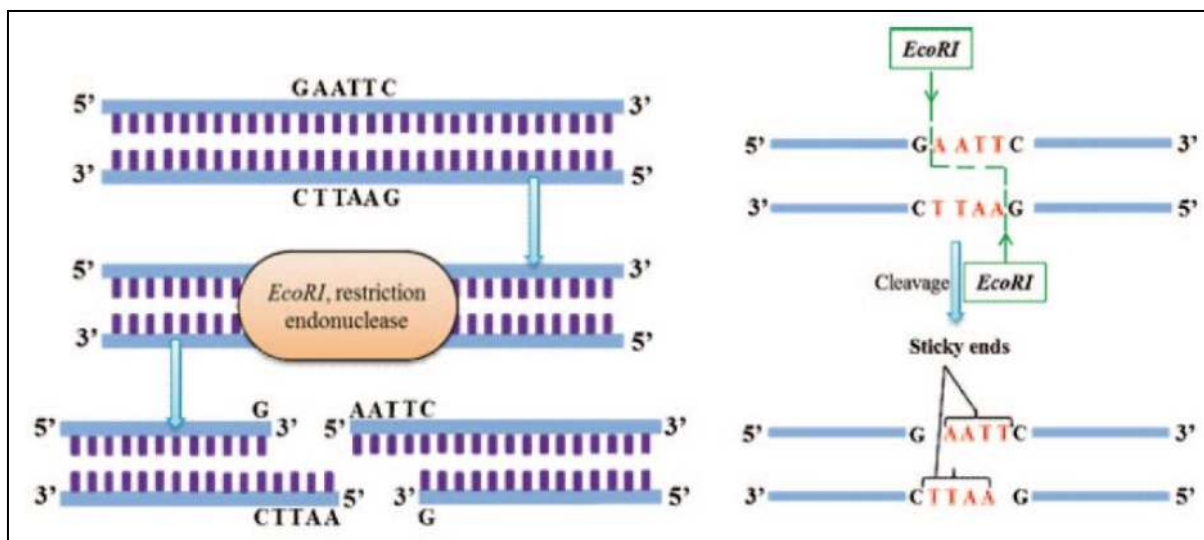

**Figure 6.** Schematic representation of restriction digestion of EcoRI at a specific site on the DNA fragments (Das and Dash, 2015).

The plasmid DNA was digested with 10 units of EcoRI in a final volume of 20  $\mu$ l (Tab. 5). The volume of each plasmid DNA was adjusted according to its concentration and transferred to Eppendorf microtubes, where mixtures of restriction enzymes, H buffer (10X), and BSA (10mg/ml) were added. The reaction mixtures were mixed gently by pipetting and centrifuged for a few seconds in a micro-centrifuge. The digestion was carried out at 37  $^{\circ}$ C for 2 h.

**Table 5.** Mixture composition of restriction enzyme digestion reaction.

Component	Volume ( $\mu$ l)
Plasmid (1 $\mu$ g/ $\mu$ l)	1
EcoRI (12U/ $\mu$ l, Promega)	0.5
H Buffer (10X)	2
BSA (10mg/ml)	0.2
Sterile Milli-Q water	16.3

After incubation, the digestion fragments were separated on 1% agarose gel. The gel was prepared as described in (Section 7.4). 8  $\mu$ l of digested plasmid DNA was mixed with 2  $\mu$ l of loading buffer. Gel electrophoresis was carried out for 30 min at 80V. Images of the gels were recorded and analyzed by a gel documentation system (Gel Doc XR+, BioRad). The positive clones were stored in 80% glycerol at -70 $^{\circ}$ C.

### c. Plasmid isolation of clones by Kit

To sequence the cloned 16S PCR products in the pGEM-T Easy vector, the plasmid DNA from the transformed bacterial suspensions were extracted and purified by the GeneJET Plasmid Miniprep Kit (Thermo Fisher Scientific) (Fig. 7).

A single colony was picked from a freshly streaked selective plate to inoculate 5 ml of LB medium supplemented with 50 µg/ml ampicillin. The culture was incubated for 12-16 h at 37 °C while shaking at 200-250 rpm. The bacterial culture was harvested by centrifugation at 6800×g in a microcentrifuge for 2 min at room temperature, decant the supernatant, and remove all remaining medium.

The pelleted cells were re-suspended in 250 µl *resuspension solution*. The bacteria were re-suspended completely by pipetting up and down until removing all remaining cell clumps. Then 250 µl of *lysis solution* was added and mixed well by inverting the tubes 4-6 times until the solution became slightly clear and viscous.

After that 350 µl of *neutralization solution* was added and mixed thoroughly by inverting the tube 4-6 times, the chromosomal DNA and cell debris were collected as pellets after 5 min centrifugation at 12,000 g. The obtained supernatant was pipetted out to the supplied GeneJET spin column.

The column was centrifuged for 1 min at 12,000 g, the flow-through was discarded, and the column was placed back. The *wash solution* (500 µl) was added to the spin column, centrifuged for 60 sec at 12,000 g, the flow-through was discarded, and the column was placed back. The washing step was repeated using 500 µl of the same wash solution. The flow-through was discarded and centrifuged for 1 min at 12,000 g to take out residual wash solution.

The GeneJET spin column was transferred to a new microcentrifuge tube (1.5 ml). To elute the plasmid DNA, 50 µl of elution buffer was added to the membrane of the GeneJET spin column and then incubated at room temperature for 2 min before centrifuging for 2 min at 12,000 g. The column was discarded, and purified plasmid DNA was stored at -20°C until the sequencing process (Thermo Fisher Scientific, 2012).

The concentration and purity were determined by measuring 1 µl of DNA (plasmid sample) Abs<sub>260</sub>/Abs<sub>280</sub> and Abs<sub>260</sub>/Abs<sub>230</sub> ratios using a NanoDrop 2000 spectrophotometer (Thermo Scientific).

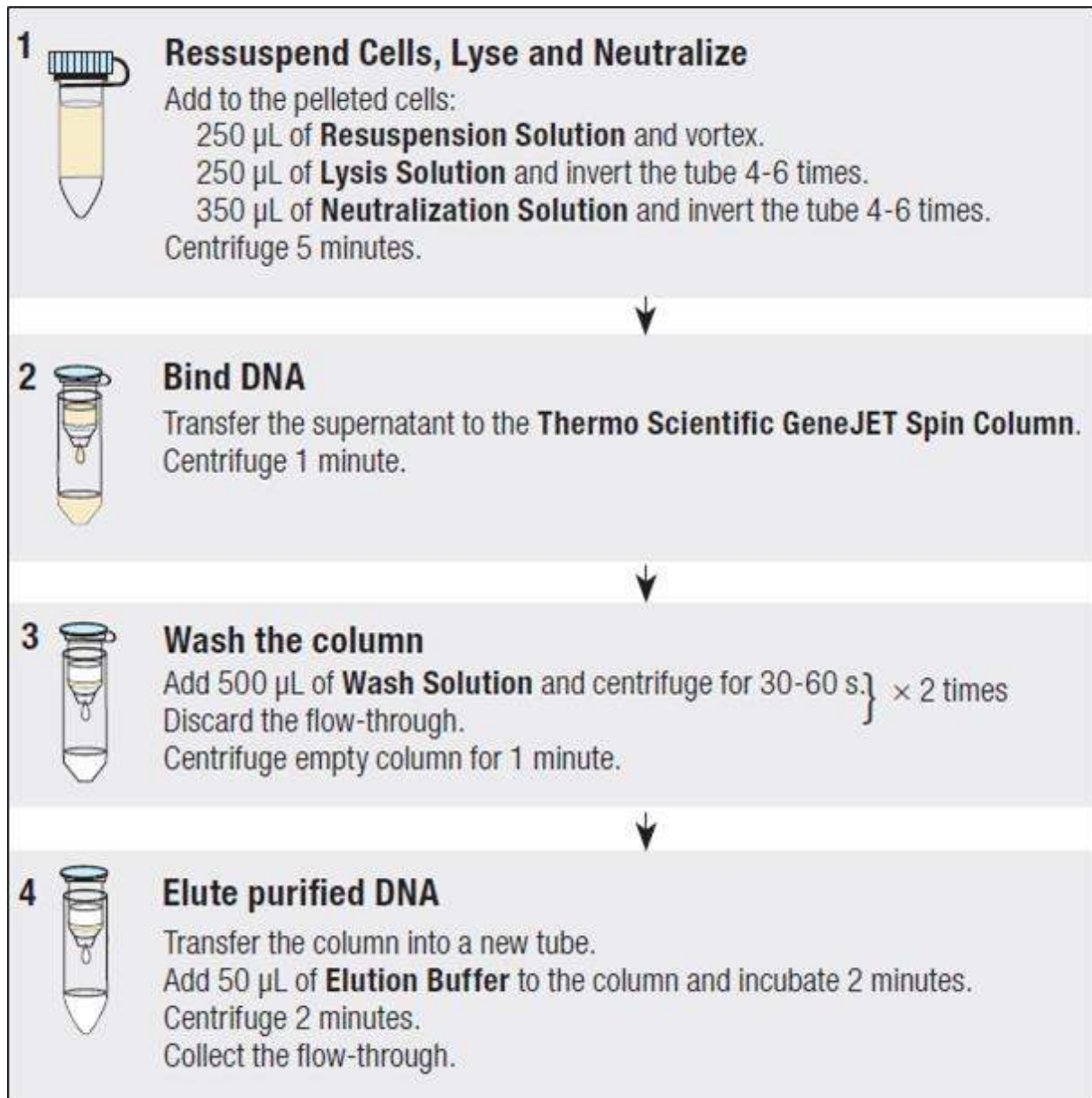

**Figure 7.** Plasmid isolation by the GeneJET Plasmid Miniprep Kit (Thermo Fisher Scientific, 2012).

### 8.6. Sequencing and phylogenetic analysis

The 16S rRNA cloned pGEM-T plasmid were sequenced with an Applied Biosystems model 373A DNA Sequencer, using the ABI PRISM<sup>®</sup> BigDye<sup>™</sup> Terminator cycle-sequencing kit (Macrogen) according to the manufacturer's instructions, using universal primers T7 (5'-TAATACGACTCACTATAGGG-3') and SP6 (5'-ATTTAGGTGACACTATAG-3') from Promega, USA.

The sequences generated were assembled using the BioEdit sequence editor version 7.2.5 (Hall, 1999), and then compared to those in the databases of the National Center for

Biotechnology Information (NCBI) website using the BLAST method (Altschul *et al.*, 1997) and the EzTaxon server (<http://www.eztaxon.org/>) (Chun *et al.*, 2007). Multiple alignments of data available from the EzTaxon server were done by CLUSTAL\_X software. Evolutionary distance matrices were generated as described by Kimura's two-parameter model (Kimura, 1980). Phylogenetic analyses were carried out using MEGA6 software (*Molecular Evolutionary Genetics Analysis*) (Tamura *et al.*, 2013). Phylogenetic trees were constructed using the neighbor-joining method (Saitou and Nei, 1987), and the topologies were evaluated by bootstrap sampling expressed as a percentage of 1000 replicates (Felsenstein, 1985).

## 9. Screening of extracellular hydrolytic enzymes

For preliminary qualitative screening of nine enzymes, the thermophilic isolates were grown on *Thermus* agar for 24-48 h. The relevant assays were performed on agar plates including enzyme-specific substrates using the drop plate technique after incubation in plastic bags at 55 °C for 1-5 days. All experiments were done in duplicates and were conducted according to the standard protocols described below.

### 9.1. Amylase activity

The amylase assay was determined in 1% (w/v) starch agar medium containing (g/l): soluble starch 10, peptone 5, yeast-extract 1, and Agar-Agar 30. Flooding plates with Lugol's iodine solution detected starch hydrolysis. The clear zone around the colony indicates a positive result (Marteinsson *et al.*, 1996).

### 9.2. Cellulase activity

For cellulase activity screening, 0.5% (w/v) carboxymethylcellulose (CMC) medium was used containing (g/l): carboxymethylcellulose 5, NaNO<sub>3</sub> 1, K<sub>2</sub>HPO<sub>4</sub> 2, yeast-extract 0.5, glucose 1, and Agar-Agar 30. The plates were flooded with Lugol's iodine solution. The clear halo around the colonies indicates the CMC hydrolysis (Kasana *et al.*, 2008).

### 9.3. Pectinase activity

The pectinolytic activity was detected on MP5 medium (Mineral Pectin 5 Medium) containing 0.5% pectin (Atlas, 2005). After incubation, the plates were flooded with iodine-potassium iodide solution (1.0 g iodine, 5.0 g potassium iodide, and 330 ml H<sub>2</sub>O). Clear zones around the colonies showed pectinolytic activity (Soares *et al.*, 1999). The medium composition is detailed in (Appendix 2).

#### 9.4. Esculinase activity

The esculinase hydrolysis enzyme was screened according to [Nabi et al. \(2016\)](#) with some modifications using a specific medium containing (g/l): peptone 10 g, esculin/aesculin 1 g, ferric ammonium citrate 20 g, Agar-Agar 30 g. Visualizing a zone of black precipitate around the colonies indicates a positive result.

#### 9.5. Protease activity

The proteolytic or caseinolytic activity was tested in 10% skim milk medium containing (g/l): skim milk 100, yeast-extract 1, and Agar-Agar, 30. Transparent clear zones around the growth were considered an indication of casein activity degradation ([White et al., 1994](#)).

#### 9.6. Gelatinase activity

The Gelatin hydrolysis assay was conducted according to the method of [Frazier \(1926\)](#) using 0.4% gelatin-based agar containing (g/l): gelatin 10, yeast-extract 1, and Agar-Agar 30. After incubation, gelatin degradation was seen as a clear zone around colonies in the somewhat opaque agar. When the plate was flooded with a saturated aqueous solution of ammonium sulfate, a precipitate was formed that made the agar more opaque and enhanced the clear zones around the colonies ([Gopinath et al., 2005](#)).

#### 9.7. Lipolytic activity

The lipolytic activity was detected according to the diffusion agar method on Tween based medium containing (g/l): 1% of tween (20 or 80), 1% Difco Bacto-peptone, 0.5% NaCl, 0.01%  $\text{CaCl}_2 \cdot 1\text{H}_2\text{O}$ ; 3% Agar-Agar (pH 7.4). A well-visible halo or turbid around the colonies indicated lipolysis ([Sierra, 1957](#)).

#### 9.8. Lecithinase activity

To determine the lecithinase enzyme, nutrient agar including (5%, v/v) egg yolk emulsion was used. The formation of a white precipitate as opalescence around or beneath the colony revealed lecithinase formation ([Priest et al., 1988](#)).

#### 9.9. Nuclease activity

The DNase activity of the strains was revealed using the DNase test agar medium with 0.5% methyl green. After incubation, DNase-producing bacteria exhibit a clear zone around growth against a green background ([Elder et al., 1977](#)).

## 10. Diversity data analysis

Thermophilic bacterial  $\alpha$  Diversity indexes, including Shannon  $H' = -\sum (p_i \times \ln p_i)$  (Shannon, 1984) evenness ( $E=H'/\log S$ ), Simpson  $D_1= 1/\sum p_i^2$  and Simpson Dominance  $D_2= 1/\sum p_i^2$  (Simpson, 1949) indexes, were calculated to infer species richness and abundance according to sampling sites, cities, and sample types. Where species richness (S) is the total number of identified bacterial species and  $p_i$  corresponds to the proportion of individuals of entire species represented by  $i$ th species (Magurran, 2004).

The Sørensen similarity index (Sørensen, 1948) was used to compare the similarity of the bacterial communities from water and sediment of hot springs.

## 11. Statistical data analysis

The analysis of variance (Two Way ANOVA) was performed testing the effect of sites, sample types, and isolation culture media on bacterial distribution recovered from hot springs. Post hoc analyses were developed with Tukey's multiple comparisons of means when  $p < 0.05$  to distinguish homogeneous and heterogeneous groups among different variables. All computations were performed using R software 3.6.2 (R-Core Team, 2020).

# CHAPTER I

*Results and discussion*

## 1. Sampling sites and physicochemical analysis

Samples of water and sediment were collected from eight hot springs prospected in Algeria from 2015 to 2017. The hot springs were located in different cities and represented from moderate thermophilic to hyperthermophilic (40.6–96°C) environments with a pH range from 6.27 to 8.03. The physical characteristics measurements were repeated over three years as triplicate described in (Tab. 6).

**Table 6.** Physicochemical characteristics of sampling sites.

Hot spring	Altitude (m)*	Water			Sediment	
		T (°C)	pH	Conductivity ( $\mu\text{s/cm}$ )	Conductivity ( $\mu\text{s/cm}$ )	pH
Saïda	682	62.60± 0.42	7.45± 0.20	1380±07.55	390±4.75	8.60±0.15
Guerdjima	655	40.60± 0.50	7.30± 0.04	7820±12.25	287±9.01	7.86±0.30
Sidi El Hadj	400	40.50± 0.30	7.25± 0.09	14,250±18.44	1280±13.23	8.13±0.18
Essalihine	1082	52.70± 1.20	8.03± 0.15	3200±3.25	400±6.50	8.54±0.23
El Knif	1020	50.10± 0.30	6.90± 0.10	3600±4.14	N.D.	N.D.
Debagh	306	96.00± 1.41	6.27± 0.25	2010±6.12	230±10.12	8.73±0.40
Belhachani	717	72.20± 0.70	6.80± 0.07	1400±3.22	1360±8.88	8.40±0.20
Guerfa	673	60.00± 1.00	7.33± 0.10	1940±7.18	300±5.02	8.69±0.14

(\*): data recovered from Google Earth Pro v7.3.2 (Mars 2021).

(N.D.): not determined.

The reason for selecting these sources to collect samples was mainly the wide range of temperatures. These different locations make hot springs exhibit a great diversity of geophysical, geochemical, and biological properties depending on the region and the origin of the waters.

Compared to those of other studies conducted in the same area, the current results are consistent for the recorded pH values, conductivity, and temperatures across hot springs (Fekraoui and Kedaid, 2005; Kedaid, 2006, 2007; Saibi, 2009; Bahri *et al.*, 2011; Amarouche-Yala *et al.*, 2015; Gomri *et al.*, 2018).

Bacteria in sediments can influence the chemistry of the overlying water through the reduction of nitrate, sulfate, and methane. The release of phosphorus and ammonium from sediments affecting many other factors like pH and conductivity, which probably explains the difference in physicochemical parameters between water and sediment (Luo *et al.*, 2019).

The temperature at the points of emergence of the different sites varied between 40.5°C at Hammam Sidi El Hadj and 96°C in Hammam Debagh, the hottest terrestrial spring in the country (Stambouli *et al.*, 2012), and the second in the world (Boukhenfouf and Boucenna, 2019). Temperature variations between the different sources are probably related to the geology of the particular area and the depth of the hot springs (Hamzah *et al.*, 2013).

The North-Eastern of Algeria hot springs shared the same geothermal system based on the following conceptual model. Meteoric water (derived from precipitation of snow and rain) goes downward through deep fractures and faults and is heated from below by a slightly high conductive heat flow; then, the heated water rises to the surface and produces the hot springs. Therefore the temperature of the hot springs depends on the depth, upwelling speed (velocity of water), and fracture characteristics (Saibi, 2009).

The temperatures of the collected thermal waters at the emergence points of all hot springs were stable throughout three samplings repeated over three years. Indeed, as it is known that thermal springs are characterized by thermal and chemical composition stability (Sharma, 2007), diurnal variation of temperature does not influence the thermal water (Mahala, 2019). In addition, Brock, (1978). has reported in his work the constancy of temperature in different hot springs over time.

The geothermal resources of Algeria are of low enthalpy type, of which emergence temperature varies between 30 and 98 °C. They are mainly located in the North. From a geological point of view, the main geothermal reservoirs are generally of the Mesozoic age characterized by limestone, sandy limestone, and sandstone type (Kedaid, 2006). They are encountered in the Triassic sandstones, liassic carbonates, and lower cretaceous formations (mainly composed of sandstones in the west and carbonate rocks in the east) (Kedaid, 2007).

Thermal water corresponds to naturally hot groundwater at the emergence with a temperature superior to the temperature of the phreatic groundwater of the given area. There is no universally accepted definition of thermal water. In France, water is described as thermal when its emergence temperature is higher than 4°C compared to the annual average air temperature of the site. In contrast, in Germany, water must have a temperature above 20°C to be described as thermal (Sonney, 2010). Some definitions place the lower temperature limit at an arbitrary value (e.g., human body temperature: ~37°C or some fixed value: 20°, 35°, 50°C, etc.) (Renaut et Jones, 2011).

According to Castany classification (Castany, 1963), the hot springs were listed into four groups depending on the water temperature at the point of emergence:

- Cold springs ( $< 20^{\circ}\text{C}$ ),
- Hypo-thermal springs ( $20^{\circ}\text{C} < T (^{\circ}\text{C}) < 35^{\circ}\text{C}$ ),
- Meso-thermal springs ( $35^{\circ}\text{C} < T (^{\circ}\text{C}) < 50^{\circ}\text{C}$ ), and
- Hyper-thermal springs ( $> 50^{\circ}\text{C}$ ).

Based on our results, the sampled thermal springs were classified into two groups: Hammam Guerdjima, Sidi El Hadj, and El Knif as mesothermal springs. The remaining five hot springs: Saïda (H05S), Essalihine (H40S), Guerfa (H24G), Belhachani (H24A), and Debagh (H24D), were listed as hyperthermal springs. The Northeastern zone of the country covers approximately 15,000 km<sup>2</sup> and remains potentially the most interesting geothermal area. This zone is characterized by springs of high flow rates and the country's highest temperature (Saibi, 2009).

The geothermal gradient (earth's internal temperature) increases with depth. However, that rate of increase is not linear and quite variable depending on the tectonic setting. Gradients are lowest in the central parts of the continents, higher in the vicinity of subduction zones, and higher still at divergent boundaries. The temperature gradient is around 15° to 30°C for every kilometer of depth within the lithosphere (the upper 100 km). The temperature drops off dramatically through the mantle, increases more quickly at the base of the mantle, and then increases slowly through the core. The temperature is around 1000°C at the bottom of the crust, about 3500°C at the base of the mantle, and approximately 5,000 °C at Earth's center (Earle, 2019).

Reservoirs of the Algerian Northeastern hot springs are generally located at depths between 1000 and 2500 m. The maximum reservoir temperature estimated using geothermometric methods is 120 °C (Kedaid, 2007). This temperature was reported in Hammam Debagh (Saibi, 2009).

The pH values of the hot springs water vary from 6.2 to 8.0. The classification of thermal water based on pH is divided into three classes following the criteria by Komatina, (2004); *slightly acidic* in Hammam Debagh (H24D) and Hammam Belhachani (H24A), *neutral* in El Knif (H40K) hot spring, and *moderately alkaline* in most of the hot springs: Saïda (H05S), Guerdjima (H05G), Sidi El Hadj (H07S), Essalihine (H40S) and Guerfa (H24G).

Besides the temperature, pH is probably the most important physical factor in thermobiotic environments (Kristjansson, 1991). pH considers the acidity or basicity of water,

which measures the relative amount of free hydrogen and hydroxyl ions in the water. The pH scale is an inverse of hydrogen ion concentration, so more hydrogen ions translate to higher acidity and a lower pH. In contrast, water that has more free hydroxyl ions is basic.

Temperature affects a wide variety of physicochemical properties of water, among that pH, which decreases at higher temperatures and vice versa (Kristjansson, 1991). Indeed, low pH values were noted in high-temperature thermal sources; it was the case of Hammam Debagh (pH=6.27, T°=96°C) and Hammam Belhachani (pH=6.80, T°=72.2°C).

Since it is not just temperature that affects the pH of an aquatic environment, other factors may interfere. Since dissolved chemicals can influence pH in the water, it is an essential indicator of thermal water.

Limestone and carbonate minerals are two elements that can help to buffer pH variations in water. Calcium carbonate (CaCO<sub>3</sub>) and other bicarbonates can neutralize pH by combining with hydrogen or hydroxyl ions. The buffering capacity (alkalinity) of water is increased when carbonate minerals are present in the sediment, keeping the pH of water near to neutral even when acids or bases are introduced. Beyond this, additional carbonate minerals can turn water slightly basic.

Conductivity in water refers to the ability of water to conduct an electric current which is determined by the presence of ionic content of dissolved solid concentration (Norbert *et al.*, 2019).

The electrical conductivity (EC) of the hot spring's water values varied from 1380 to 14,250 µS/cm. Most of the samples (6/8 samples) having high values of EC (> 2000 µS/cm). The relatively high EC in the different samples can be explained by the lithological composition (the concentration and the type of dissolved ions), the hydrothermal alteration of sedimentary rocks, and the high temperature (Bahri *et al.*, 2011).

Water categories based on EC, according to Rhoades classification, are divided into six types (Rhoades *et al.*, 1992):

- Type I is non-saline: if EC < 700 µS/cm,
- Type II is slightly saline: if EC varies between 700 and 2,000 µS/cm,
- Type III is moderately saline: if EC is higher than 2,000 and less than 10,000 µS/cm,
- Type IV is highly saline with EC value from 10,000 till 25,000 µS/cm,
- Type V is very highly saline: if EC value between 25,000 and 45,000 µS/cm, and
- Type IV is brine water with EC more than 45,000 µS/cm.

According to Rhoades classification, the Algerian thermal springs are classified into three groups: the first-class involves spring with lower conductivity values, 700-2,000  $\mu\text{S}/\text{cm}$ . This class includes the hyper-thermal springs Saïda (H05S), Belhachani (H24A) and Guerfa (H24G). The second class includes thermal springs with EC ranged between 2,000 and 10,000  $\mu\text{S}/\text{cm}$  such as Essalihine (H40S), El Knif (H40K), Debagh (H24D), and Guerdjima (H05G) hot springs. The last class with conductivities ranging between 10,000 and 25,000  $\mu\text{S}/\text{cm}$ , as in mesothermal springs of Sidi El Hadj (H07S) characterized by highly saline sodium chloride-rich waters.

Indeed, high temperature favors the dissolution of mineral salts from the Triassic formations in sufficient quantities along the hot water path through the earth's crust. Ions can move faster in warmer water; thus, the conductivity of water increases with rising temperature. EC increase by approximately 1.9% for every 1°C increase in water temperature (APHA, 2005).

The electrical conductivity of water is directly related to the concentration of dissolved ions in the water. As each ion may carry an electrical charge, water with more ions can conduct a tremendous amount of current. The concentration of dissolved ions is the most important of the main factors affecting EC. While electrical conductivity is a good indicator of the total salinity, it does not provide any information about the ion composition in the water.

Ions have different abilities to transmit charges. Inorganic ions such as  $\text{Na}^+$ ,  $\text{K}^+$ ,  $\text{Mg}^{+2}$ ,  $\text{Ca}^{+2}$ ,  $\text{HCO}_3^-$ ,  $\text{Cl}^-$  and  $\text{SO}_4^{-2}$  conduct electricity well. Although, each ion has a different ability to conduct electricity. This depends on many factors, such as the ion charge, size, valency of metals, and its tendency to interact with water molecules. Heavier ions tend to move slower, but small ions can strongly attract water molecules, resulting in a slow-moving hydrated ion. Organic substances tend to make poorer electrolytes than inorganic substances primarily because they have a relatively weak tendency to dissociate into ions (Haynes, 2009).

Hammam Sidi El Hadj has the highest conductivity value with 14,250  $\mu\text{S}/\text{cm}$ . Conductivity is directly related to the concentration of present ions. Higher conductivity may be attributed to high salinity and high mineral percentage in groundwater samples, generally due to the aquifers' ion exchange and solubilization process (Bozdağ and Göçmez, 2013). Indeed, the plaine of El-Outaya is characterized by very salted soil (Marini and Talbi, 2009). Located in the South of Djebel El-Melah (Salted Mountain), this region is known as El Outaya salt mine, which has been exploited since 1976 and is operated by the Algerian company ENASEL.

The hydrographic network of the region is represented by a sub-watershed of the Chott Melghir, whose main outlet is Oued El-Hai (Rouahna, 2019), receiving on its left bank some tributaries from the Aures Mountain and the streams of brackish water flowing almost continuously in deep notches on the periphery of Djebel El-Melah, such as Oued El-Melah (Brinis, 2011). The electrical conductivity of sediment was much lower than that of water of hot springs; values varied from 230 to 1280  $\mu\text{S}/\text{cm}$ .

Indeed, the thermal waters of the studied hot springs are of meteoric origin, derived from the precipitation of snow and rain. The main factor controlling the chemical composition is water-rock interaction (Kedaid, 2007).

The Northeastern zone of the country consists mainly of carbonate formations. The neritique constantinois formations and the carbonate part of the Tellian sheet form the reservoirs of Guelma and Bouhadjar, respectively. The thermal waters in this area are chemically dominated by chloride and sulfate (Saibi, 2009). These results agree with the chemical facies of the three studied thermal springs belonging to Guelma City reported in several research (Fekraoui and Kedaid, 2005; Ouali, 2015; Bekkouche, 2016).

## 2. Isolation and distribution of thermophilic bacteria

The 40 samples of water and sediment from the eight hot springs were served to isolate thermophilic bacteria on six different culture media. The multiplication of samples is only intended to obtain a wide range of bacteria.

At the end of the incubation period at 55°C, representative colonies per sample and medium were selected and purified by successive streaking at least twice until a pure culture was obtained on the same isolation medium and temperature. The choice of isolation temperature (55°C) is justified by the fact that most heterotrophic thermophilic bacteria have optimal growth temperatures between 50 °C and 60°C (Holden, 2009).

Using six different culture media to isolate the bacteria, we obtain many different morphologies; sometimes, even the same bacterial species changes morphology from one culture medium to another. As a result, we subculture all the purified colonies on a single culture medium; the choice fell on the TT medium (ATCC medium 697). This culture medium has promoted the growth of all thermophilic isolates.

## 2.1. Distribution according to sampling sites

Throughout the sampling period, a total of 293 thermophilic strains were isolated from the different hot springs. According to the distribution, 17.57% (52/293) of all the strains belong to Debagh hot spring (H24D), followed by Belhachani hot spring (H24B), Essalihine hot spring (H40S), Guerdjima hot spring (H05G), Sidi El Hadj hot spring (H07S) and Saïda hot spring (H05S) with 16.04%, 14.68%, 14.33%, 12.29 %, and 11.95% respectively. El Knif hot spring (H40K) and Guerfa hot spring (H05G) presented the lowest number of isolates, 6.83% (20/293) and 6.14% (18/293), respectively, of all isolates (Fig. 8). High variability of thermophilic richness was noted according to the sampled sites. These results show that the distribution of the strains was heterogeneous.

The composition of microbial communities in the thermal springs is widely dependent on the temperature, pH, residence time, and physicochemical parameters (Amin *et al.*, 2017).

The occurrence of isolates in different locations may result from the prevailing environmental conditions and the chemical properties of the water and sediment of the various hot springs. Suggesting that the environment selects those strains better thriving under those specific conditions, which agree with the description of highly parceled habitats at Thailand hot springs (Cuecas *et al.*, 2014).

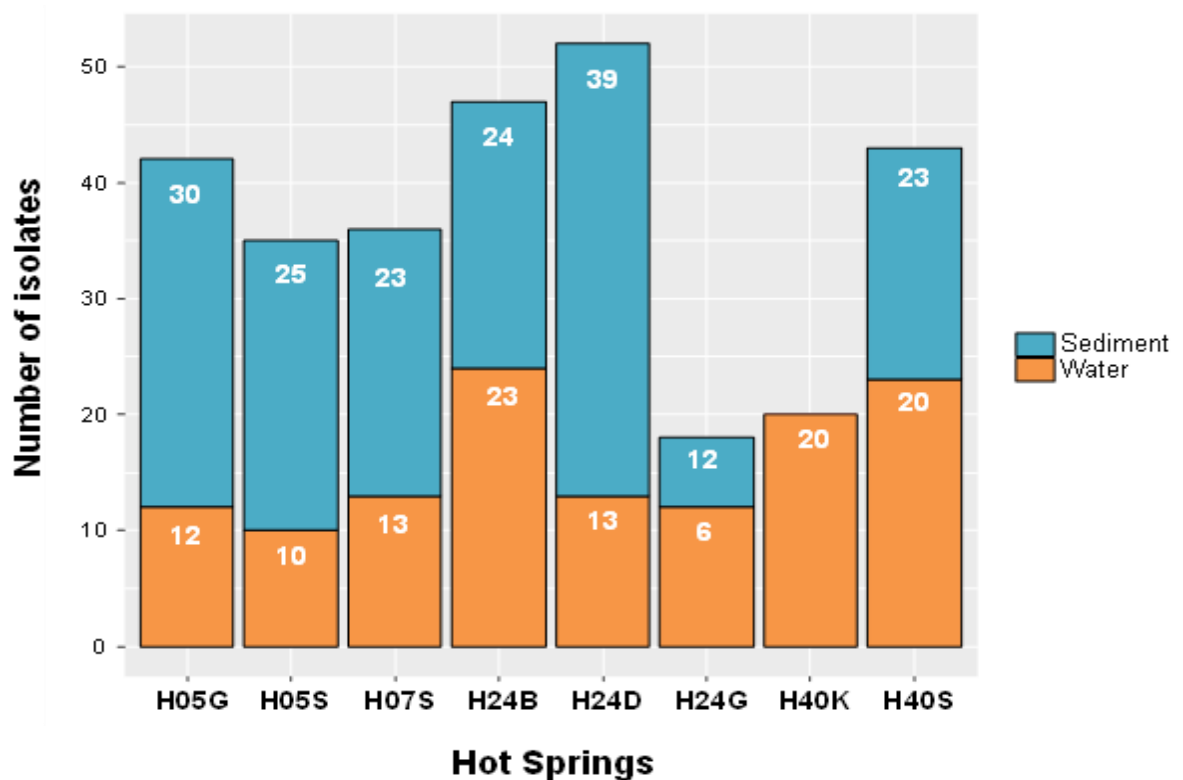

**Figure 8.** Distribution of isolates from sediment and water based on sampling sites.

## 2.2. Distribution according to sample types

Isolation and purification procedures were carried out with both water and sediment samples. Sediment samples from all hot springs provided 51.32% (166/293) isolates, while water samples allowed the isolation of 48.68% (127/293) isolates (Fig. 9). No significant difference was reported among sampling types ( $p < 0.70$ ) (Tab. 7). However, sediment samples presented higher diversity than water samples. Water showed more stable culturable communities, which were dominated by a low number of major representative species.

Bacteria are 2–1000 times more plentiful in sediment than in the overlying water section of freshwater biological ecosystems (Luo *et al.*, 2019). Microbial community composition and abundance of deposits are influenced by high nutrient content, especially organic matter, dissolved oxygen, nitrogen, and phosphorus levels; these key factors cause differences in microbial community structure compared to water (Pala *et al.*, 2018; Li *et al.*, 2019).

However, the culture-dependent method for microbial communities' characterization in hot springs allows the isolation of a lower number of isolates than the whole-cell load present on that sample. Therefore to overcome such problems, researchers are currently relying more extensively on a culture-independent molecular approach to assess unexplored biodiversity (Panda *et al.*, 2018). Many researchers using these approaches indicated that sediment's microbial richness and diversity were higher than in water (Hou *et al.*, 2013; Valeriani *et al.*, 2018; Zhang *et al.*, 2019).

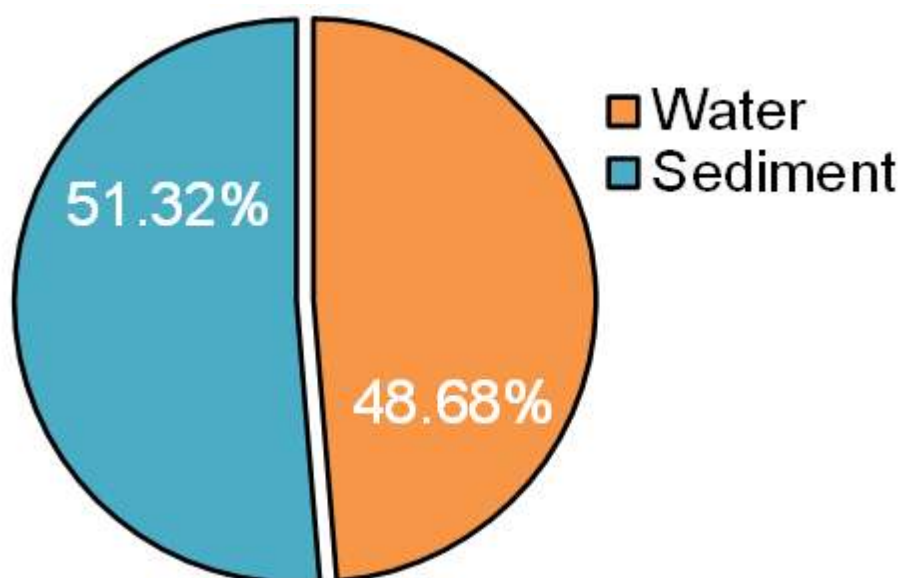

**Figure 9.** Frequency of isolates from water and sediment samples.

### 2.3. Distribution according to isolation methods and culture media

A total of six media were employed to retrieve the culturable bacteria. 57.68% of total isolates have been cultured on specific media (Thermus medium, ATCC medium 697, Thermus 162 medium). In comparison, 42.32% were isolated from non-specific media distributed into 6.14% from a minimum medium (Castenholz medium D) and 38.18% from standard culture media (Nutrient agar and Tryptic soy medium). The number of thermophilic bacterial populations recovered is dependent on the type and media composition (Fig. 10). Analysis of variance revealed a very highly significant effect ( $P < 0.0001$ ) of the culture media type on the number of isolated thermophilic strains (Tab. 7).

The reason for using multiple culture media for isolation was to obtain a wide range of bacteria. Nutrient agar and Tryptic soy medium were employed for isolating a large proportion of the available diversity, mainly the thermotolerant isolates; both media support the growth of bacteria from hot springs when incubated at high temperature (Kumar *et al.*, 2014; Arya *et al.*, 2015). Thermus medium, ATCC medium 697, and Thermus 162 medium were suitable for isolating many thermophilic genera (*Meiothermus*, *Thermus*, *Aeribacillus*, *Anoxybacillus*.... etc.), including a variety of novel species (Inan *et al.*, 2016; Zhou *et al.*, 2018).

It has been known for quite a while that the quantity of isolated bacteria on microbiological media is commonly just a small part of the total number of microorganisms in the sampled environment (Davis *et al.*, 2005). The use of unstandard media (Thermus medium, ATCC medium 697, and Thermus 162 medium) allowed the isolation of many strains with different morphological aspects that were not detected on other standard media. These culture media were formulated to mimic the hot spring's water composition to allow sufficient biomass formation.

The Castenholz medium D was the poorest of the six investigated media, resulting in fewer isolates (6.14%). This medium was initially intended for the isolation of blue-green photosynthetic algae of hot springs. The medium contains minerals with the only organic compound, the metal chelator nitrilotriacetic acid (NTA), used as a carbon and nitrogen source (Castenholz, 1970). The use of the medium extended to the isolation of certain types of thermophilic bacteria, such as the genus *Thermus* which required a low concentration of organic compounds since growth is inhibited by higher organic nutrient levels, mainly by monosaccharides (Albuquerque, 2018).

Despite their extensive taxonomic diversity, most known thermophiles have a heterotrophic metabolism, preferentially using complex mixtures of polypeptides and

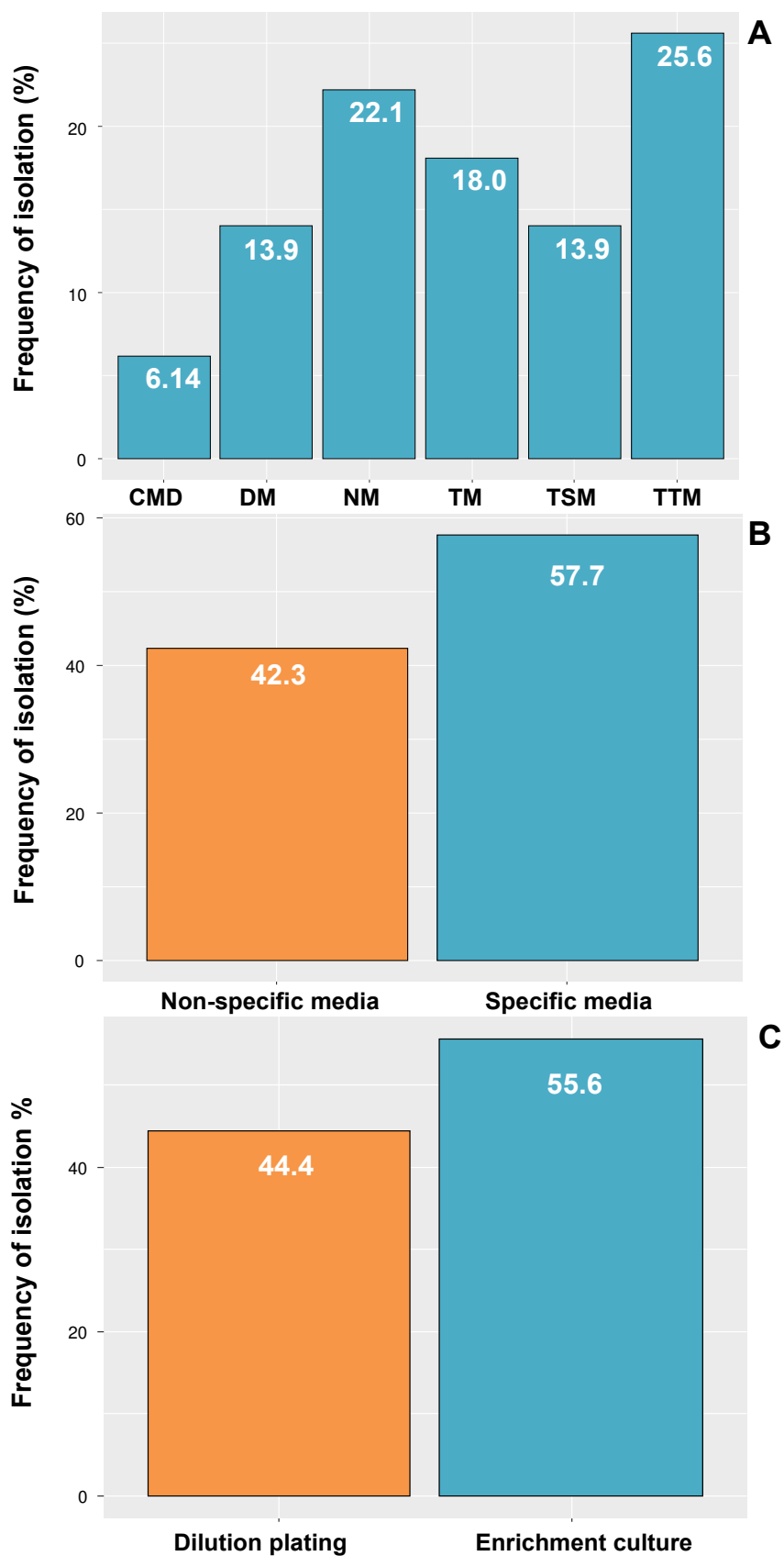

**Figure 10.** Isolation frequency of thermophilic bacteria. (A) Depending on the type of culture media. (B) On the nature of media. (C) On the isolation technique. **CDM:** Castenholz D medium, **DM:** Degryse medium, **NM:** Nutrient medium, **TM:** Thermus medium, **TSM:** Tryptic soy medium, **TTM:** TT medium.

carbohydrates as energy and carbon sources. In addition, all hyperthermophiles and many species of thermophiles are chemosynthetic rather than photosynthetic, deriving energy by the reduction or oxidation of organic and inorganic compounds (Amend, 2001). This kind of metabolism tends thermophiles to grow well on standard culture media like Nutrient agar and Tryptic soy medium (Adiguzel *et al.*, 2009; Arya *et al.*, 2015).

Many aerobic thermophilic bacteria are endospore-forming; this justifies the use of TSA, the most suitable medium for spores germination (Logan *et al.*, 2000). This medium is considered the best recovery medium, yielding clear, easily countable colonies, supporting germination and outgrowth of the sporulating bacteria (Wells-Bennik *et al.*, 2019).

The liquid enrichment and dilution plating methods used in this study appeared to adequately support the growth of thermophiles of hot springs when incubated at the same high temperature. 44.37 were retrieved using a direct plating method, and 55.63 % of total isolates could use the liquid enrichment technique (Fig.10).

No significant difference was reported quantitatively among isolation techniques ( $p < 0.06$ ) (Tab.7). However, the qualitatively liquid enrichment method allowed the isolation of a wide range of distinct morphological aspects that were not detected by the dilution plating method. Furthermore, all the probably novel species in this study were isolated after enrichment.

Liquid culture media facilitate access to nutrients for bacteria. These supplements are more accessible as the culture media are incubated under agitation, allowing renewal of nutrients for bacteria; however, access to nutrients in solid culture media may be limited.

Broth-enrichment is frequently used to increase the detection of bacteria, especially when the transfer of samples to the laboratory might be prolonged; it allows improving the recovery of bacteria (Barer, 2012).

On the other hand, in our case, 3% agar-agar was added to the solid medium to prevent desiccation at high temperatures. Especially during long incubation periods, as is recommended for the isolation of thermophiles. However, culture media with high agar-agar concentration will form smaller colonies than low agar content media because the nutrient flow and toxin removal are reduced. In addition, it has been proved that agar in excessive amounts can inhibit the growth of certain bacteria, featuring the need to find other gelling agents (Bonnet *et al.*, 2020).

Agar-based media are stable up to 65°–70 °C. However, at temperatures greater than 70°C, agar-agar starts losing gel strength and often manifests syneresis, with the expulsion of

water from the gel, making the medium useless for the isolation of thermophilic bacteria. Even with a temperature of 55 °C for a long incubation period, these troubles are often frequent, making isolation of thermophilic bacteria hard.

Agar substitutes such as Gelrite (gellan gum) are used in a solid medium that remains solid and stable at high temperatures giving thermal stability and better clarity than agar. Gelrite, which is a naturally derived and highly purified polysaccharide, demonstrate superior performance over agar-agar as a gelling agent in culture media for growing different thermophilic microorganisms, with a lower concentration (0.4% to 0.8%) to obtain sufficient gel strength, good clarity for visualization of small colonies, and contains no contaminating matters (e.g., phenolic compounds) than did the agar-based media (Lin and Casida, 1984; D'Souza *et al.*, 1997).

Using gelling agents such as Gelrite and nanofibrous cellulose instead of agar-agar could potentially increase the diversity of isolates capable of forming colonies on solid medium, especially among thermophiles (Urbieta *et al.*, 2015). The only obstacle to the use of Gelrite during this study is the high price and its unavailability in the national commercial sector.

**Table 7.** Outcomes of ANOVA testing the effect of sampling site, samples type, culture media, and culture methods on the number of thermophilic isolates (\*\*\*: very highly significant, NS: no significant).

Source	Variable	DF	SS	F	P	Significance
<b>Thermophilic isolates</b>	Sample type	7	74.28	0.66	0.70	NS
	Hot springs	1	95.06	0.85	0.39	NS
	Residuals	7	112.92			
<b>Thermophilic isolates</b>	Culture media	8	3716.55	28.10	<0.0001	***
	Hot springs	1	450	3.40	0.10	NS
	Residuals	8	132.25			
<b>Thermophilic isolates</b>	Culture methods	7	74.28	3.39	0.06	NS
	Hot springs	1	68.06	3.10	0.12	NS
	Residuals	7	21.92			

*DF*: Degrees of freedom, *SS*: Sum-of-squares, *F*: F ratio, *P*: P values.

### 3. Preliminary characterization of isolates

#### 3.1. Morphological characterization

Very significant differences were noted among the 293 presumptive thermophilic isolates in terms of morphologic, biochemical, and physiological properties. Morphologically, the isolates showed some variation in color (Fig 11). Colonies were grey, black, creamy and creamy-gray, buff, white and off-white, yellow to bright yellow, pink, orange, and red. The pigments produced by the isolated species were endocellular and nondiffusible.

The colonies show a wide range of colonial morphologies; some isolates were circular or irregular with a margin of entire to undulate or crenate uneven edges. They have wrinkled, rough, granular, crusty, or smooth textures. Other colonies were rhizoid or hairy-looking and adherent, covering the whole agar surface, showing spreading growth. Pleomorphism has also been detected in some Petri dishes, showing cells and filaments with swollen regions and entirely swollen cells. This kind of growth may be observed in cultures grown in suboptimal conditions. Consistency was usually moist and glossy; others were butyrous or mucoid. Matt's colonies were minor. Isolated colonies were either opaque or translucent.

The colonies ranged in size from small to large with diameters of 0.6 to 10 mm. Colonies of the thermophilic species may be larger, up to 12 or 15 mm in diameter, particularly with species showing a tendency to swarm across the surface of the agar.

Another aspect was noted in isolates formed after 3 days of incubation at 55°C; a mycelial growth colony (30 isolates) of variable sizes and colors. Colonies were fast-growing; these bacteria showed abundant and white, gray-green to dark green aerial mycelia, substrate mycelia were white, cream, pale yellow, or green, none isolates showed production of diffusible pigments in the medium that we used for initial isolation.

The microscopic observation allowed determining some morphological characteristics of bacterial cells after differential Gram and endospore staining. Most isolates were rod-shaped cells and occurred singly, in pairs, in a short or long chain. Based on Gram staining, around 78% of the isolates were mainly found to be Gram-positive. Similarly, [Narayan et al. \(2008\)](#) reported the dominance of Gram-positive thermophilic bacteria from Savusavu hot Spring in Fiji. A fraction of the isolate was a Gram variable; therefore, the molecular biology identification will decide their Gram affiliation. The spores were ellipsoidal, cylindrical, round, or oval, with a terminal, subterminally, central or paracentral position. In some species, endospores were not observed, mainly Gram-negative isolates.

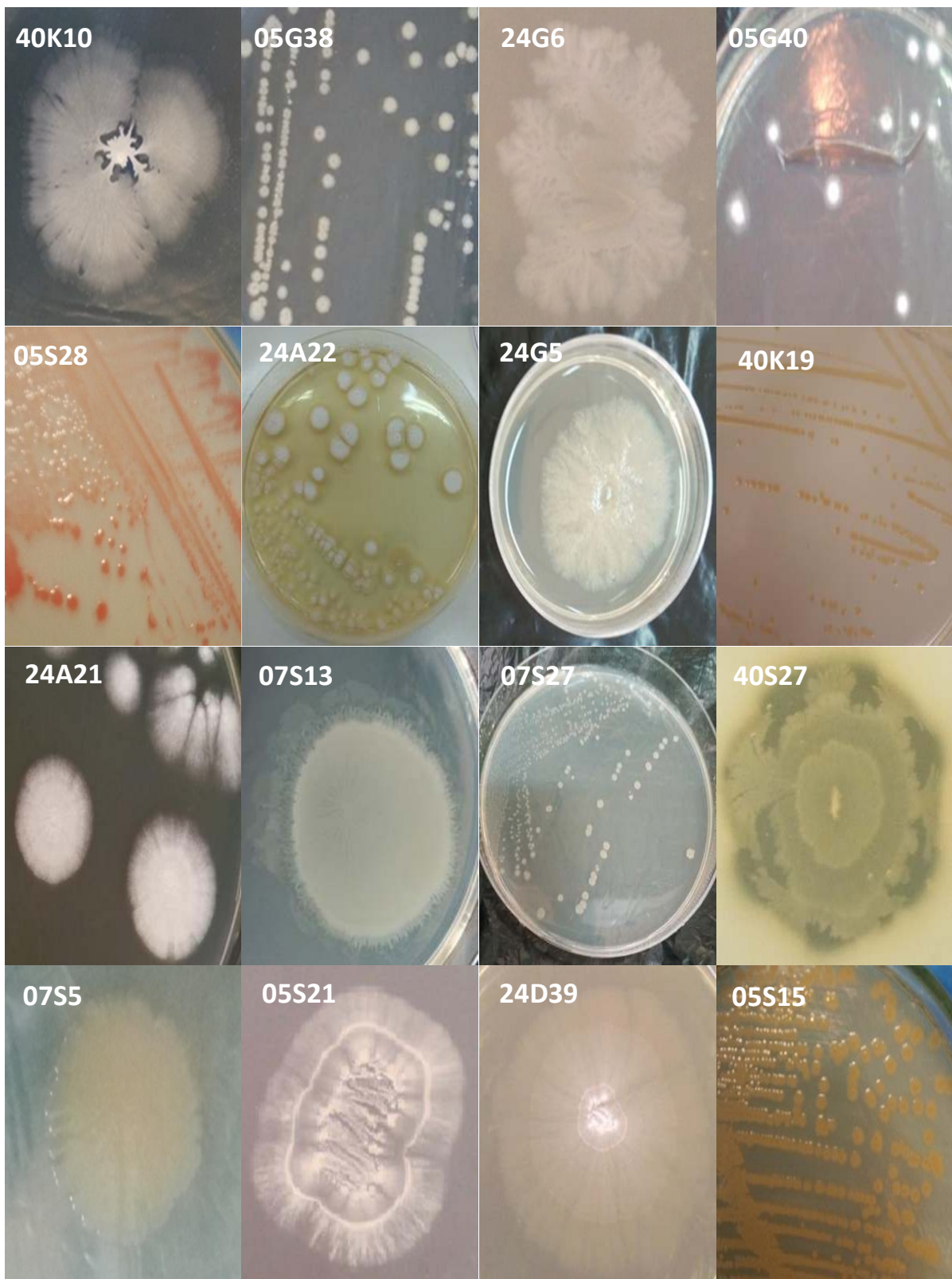

**Figure 11.** Different phenotypic aspects of some thermophilic isolates. **40K10:** *Aneurinibacillus thermoaerophilus*, **05G38:** *Aeribacillus composti*, **24G6:** *Geobacillus icigianus*, **05G40:** *Aeribacillus pallidus*, **05S28:** *Meiothermus ruber*, **24A22:** *Thermoactinomyces vulgaris*, **24G5:** *Geobacillus stearothermophilus*, **40K19:** *Brevibacillus aydinogluensis*, **24A21:** *Laceyella sacchari*, **07S13:** *Bacillus paralicheniformis*, **07S27:** *Bacillus licheniformis*, **40S27:** *Brevibacillus aydinogluensis*, **07S5:** *Bacillus hisashii*, **05S21:** *Thermoactinomyces vulgaris*, **24D39:** *Thermobifida fusca*, **05S15:** *Anoxybacillus pushchinoensis*.

### 3.2. Physiological characterization

All isolates screened for temperature tolerance were able to grow between 30-80°C with variation among strains. It was noted that all isolates (293 isolates) develop at 55°C within 24h to 1 week. Of which 40.20% were found to tolerate 65°C, 10.87% could support 75°C (moderately thermophilic), while only 5.11% of isolates could grow at 80 °C (extremely or obligate thermophilic). Moreover, 52.82% of isolates could grow at 37 °C. Salt was not required for growth since all the strains were able to grow in the unsupplemented medium. The isolates tolerated salt concentrations in medium supplemented with 1 to 15% NaCl (w/v). In contrast, none of the strains grew in medium supplemented with 20% NaCl (w/v). The number of bacteria decreased at high salt concentrations. In addition, the pH values tested ranged from 5.0 to 9.0. Almost all strains grow at near neutral to slightly alkaline pH ranging between 6.5 and 8.5.

The physiological and even morphological characteristics turned too challenging to differentiate isolates; this is well known and in accordance with previous microbiological descriptions (Aanniz *et al.*, 2015).

### 4. SDS-PAGE analysis

To exclude the effect of temperature and medium on protein patterns, all the thermophilic strains were inoculated in the same medium and incubated at the same temperature and incubation time. The electrophoretic patterns of whole-cellular proteins from all isolates, resulting from SDS-PAGE, showed that five groups could be delineated at a similarity level of 45% (Fig. 12). Cluster I include 42 strains grouped into four sub-clusters (A): six, (B), 15, (C) 12, and (D) nine strains with a similarity of 45,55,61 and 59%, respectively. Cluster II also was grouped into four sub-clusters assembling 171 isolates distributed as 134 from sub-cluster (C) with a similarity of 54%, followed by 23 strains in sub-cluster (B) of 59% similarity, both sub-clusters (A) and (D) including seven isolates. Finally, clusters III, IV, and V have only one isolate for each belonging to three different hot springs, distributed as 05S37, 07S35, and 24A17, respectively. One hundred representative strains from several clusters were selected for further molecular identification by 16 rRNA gene sequencing.

The analysis of SDS-PAGE whole-cell protein patterns has proven to be highly reliable for comparing and clustering a large number of mesophilic bacteria growing on identical conditions and belonging to different genera such as Gram-positive bacteria *Bacillus*, *Mycobacterium*, *Staphylococcus*, *Streptococcus*, *Brevibacterium*, and lactic bacteria (Tsakalidou *et al.*, 1994; Kämpfer, 1995; Esteban *et al.*, 2003; Vandamme *et al.*, 2009; Kim *et*

*al.*, 2010; Santos *et al.*, 2012), and Gram-negative bacteria like *Leptotrichia*, *Salmonella*, *Klebsiella*, and *Pseudomonas* (Costas *et al.*, 1990; Vancanneyt *et al.*, 1996; Eribe and Olsen, 2002; Aksakal, 2010).

However, there is very little research about the application of this technique on thermophilic species. Based on the importance of detecting and identifying the amino acids present in microorganisms to differentiate and identify different mesophilic bacteria (Fox *et al.*, 1990). Firstly, it was proved that thermophilic bacteria could be identified by their amino acid composition deduced from their complete genome sequences. Investigating the analysis by hierarchical clustering and principal components analysis; the global amino acid compositions of 27 species distributed as follows; six thermophilic archaea, two thermophilic bacteria, 17 mesophilic bacteria, and two eukaryotic species, affirm the possibility to identify thermophilic species based on their amino acid compositions (Kreil and Ouzounis, 2001).

Later on, another research suggested that the whole protein profiles by SDS-PAGE of 170 strains of thermophilic bacteria isolated from deep-sea hydrothermal fields in the Pacific Ocean and a hot spring in Xiamen of China provide discrimination between species with high resolution. The SDS-PAGE results demonstrated four different protein patterns (clusters), showing that the 170 strains could belong to four species or genera. The random amplified polymorphic DNA (RAPD) profiles of representative strains from each cluster were consistent and reliable with SDS-PAGE results. To additionally identify the representative species, their 16S rRNA gene sequences were examined. The outcomes demonstrated that the strains fell into four species of three genera, the same as evidenced by SDS-PAGE (Liu *et al.*, 2006).

Inan *et al.* (2011b) suggested classifying nine strains belonging to the *Anoxybacillus* genus based on the SDS-PAGE profile. The electrophoretic patterns of the soluble cellular proteins of the strains revealed that isolates AC26, ACT2Sari, ACT14, and I4.1 were similar. Isolates B9.3 and I4.2 were identical, and BT2.1 and CT1Sari share the same profile. The isolate (I3) was not identical to any other group of isolates. The 16S rRNA gene sequencing analysis allowed classifying the three isolates I3, CT1Sari, and BT2.1 as *Anoxybacillus gonensis*; I4.2 and B9.3 isolates as novel strains of *A. voinovskiensis*; and I4.1, AC26, ACT14, and ACT2Sari isolates as new strains of *A. kestanbolensis*. All results regarding SDS-PAGE profiling for thermophilic bacteria classification showed excellent efficiency and rapidity in the differentiation of thermophilic species before further identification by genomics tools, mainly the 16S rRNA gene sequencing.

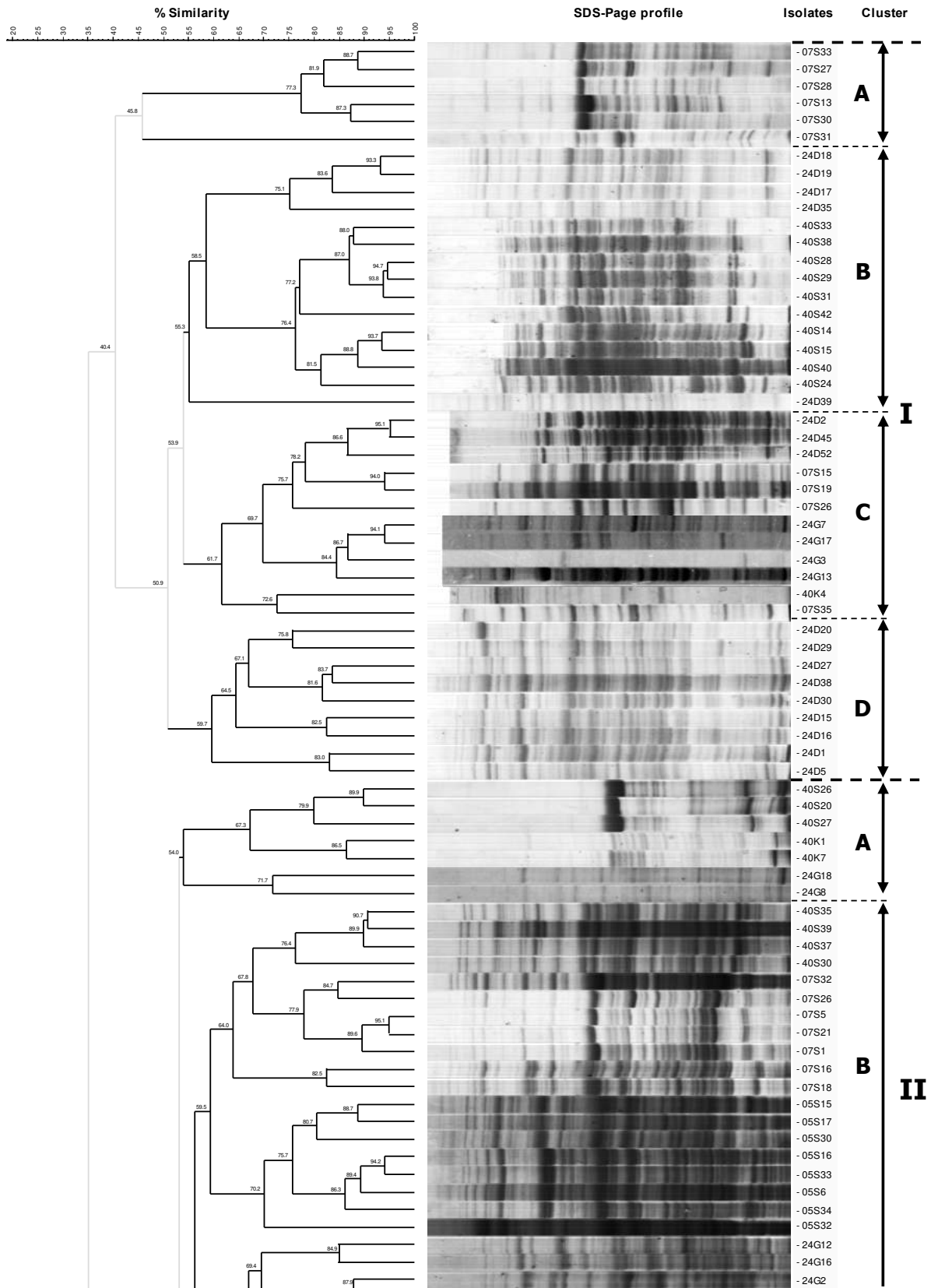

**Figure 12.** Dendrogram of similarity based on SDS-PAGE of whole-cell protein pattern analysis from thermophilic bacterial isolates. The right side of the figure represents the strains number.

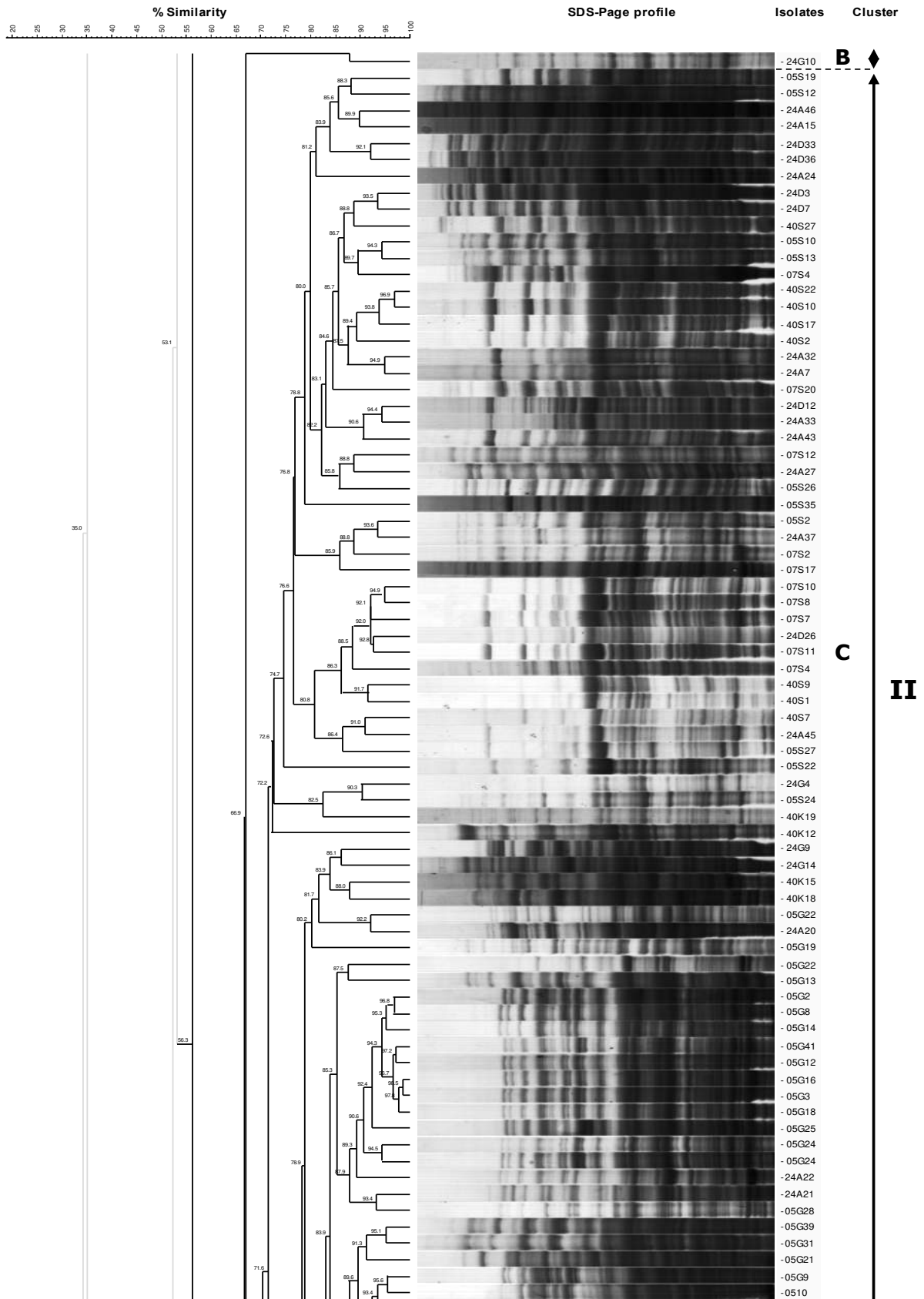

Figure 12. Continued

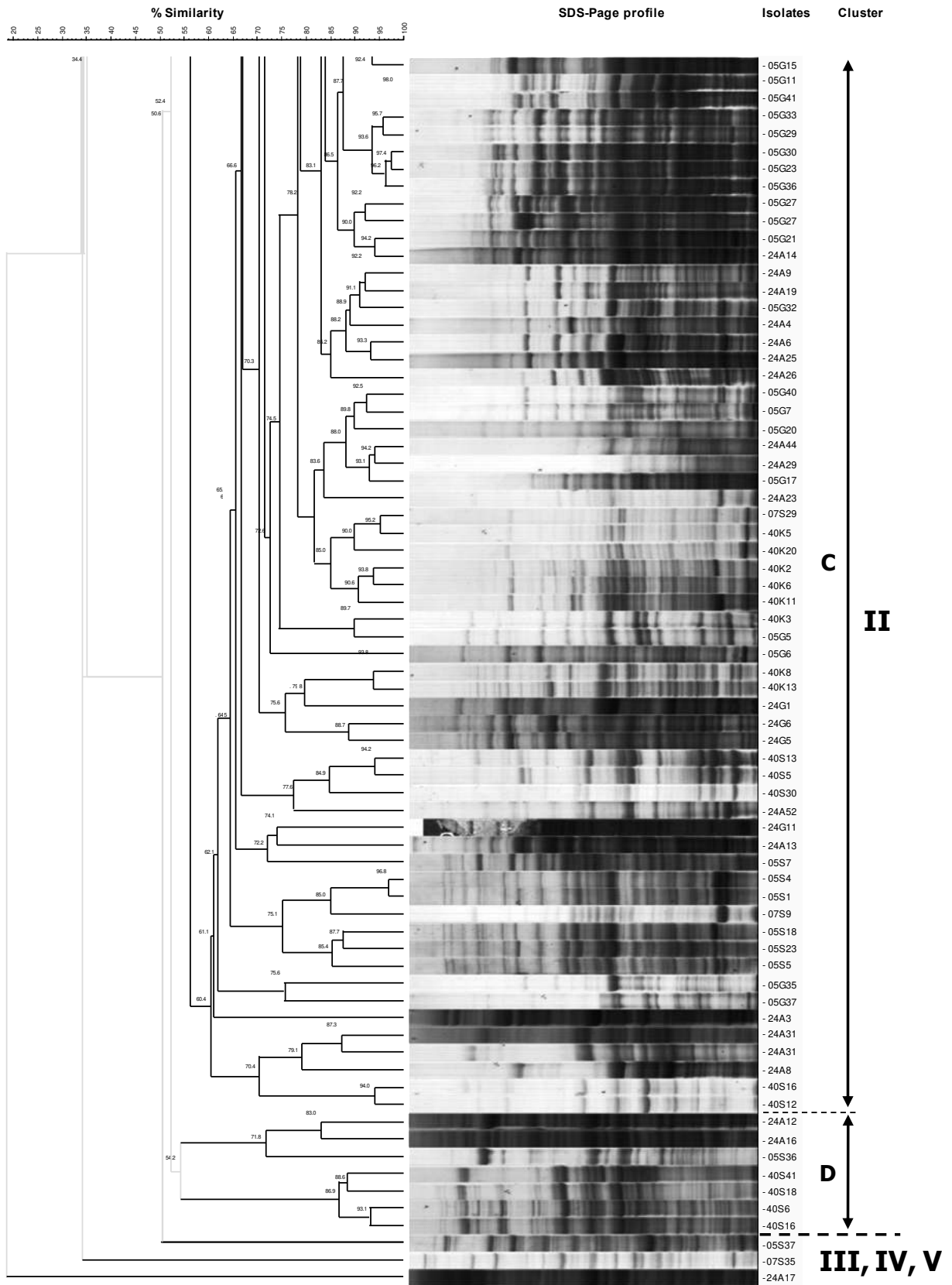

Figure 12. Continued

## 5. Molecular identification and phylogenetic analysis

### 5.1. Amplification of 16S rRNA genes

The sequencing of the 16S rRNA gene has been extensively studied to determine the classification of *Bacteria* and *Archaea*. One of its most important assets is the ability to identify isolates to genus and species levels that do not match any recognized biochemical profile (Janda and Abbott, 2007).

The comparison of the 16S rRNA gene sequence of an isolate against sequences of the type strains of all prokaryotic species in different databases such as GenBank and EzTaxon provides an accurate and convenient way to routinely classify and identify prokaryotes with 98.65% similarity currently recognized as the cutoff for delineating species (Kim and Chun, 2014).

The use of 16S rRNA gene sequences to study bacterial phylogeny and taxonomy has been by far the most common marker used for many reasons:

- i. The 16S rRNA gene sequence is highly conserved; its function has not changed over time, suggesting that random sequence changes are a more accurate measure of time (evolution),
- ii. The presence in almost all bacteria, often existing as a multigene family or operons,
- iii. The 16S rRNA gene is about 1,500 bp long; it is large enough to provide distinguishing for informatics purposes,
- iv. The 16S rRNA gene sequence is composed of both variable and conserved regions. Universal primers are usually chosen because they complement the conserved regions that amplify 16S rRNA genes from widely divergent bacteria (Clarridge, 2004; Janda and Abbott, 2007).

The genomic DNA from 100 isolates was extracted using the Wizard® Genomic DNA Purification Kit by Promega (USA), and the PCR amplified the 16S rRNA gene. To verify the success of the reaction, 1% agarose gel of the amplicons produced was performed. The result indicates a DNA sequence of approximately 1,500 bp, which corresponds to the size of the targeted gene (Fig. 13).

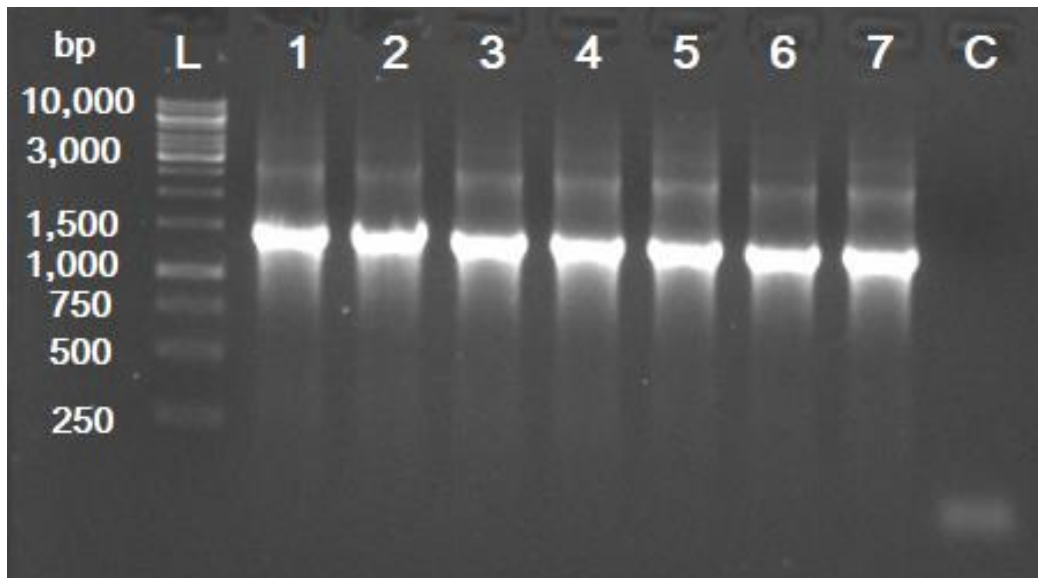

**Figure 13.** PCR amplification products of the 16S rRNA gene from seven isolates. (L): ladder GeneRuler 1Kb DNA, (C): negative control.

## 5.2. Sequencing of the 16S rRNA genes

The 16S rRNA PCR products previously obtained were cloned using the pGEM-T Easy Vector System (Promega, USA) according to the manufacturer's directions (Section 8.5. Materials and Methods). The 16S rRNA can be sequenced directly after purification or can readily be cloned for sequencing. In our case, we selected the PCR cloning method for the many advantages it offers:

- A. Having a "stock" of our PCR products for future works on it,
- B. Usually, the first 10-50 bp of the Sanger sequence fragments do not have good reading (content much noise). To have the complete sequence of the PCR product, we clone it into a vector; thus, we can perform sequencing using specific primers from the vector,
- C. To detect point mutations, we can sequence several clones,
- D. Getting a better-quality read from a plasmid due to a reduction in incomplete amplification that can be a problem when sequencing from a PCR product,
- E. DNA in a plasmid goes through a proof-reading process when replicated in the host cell, with fewer variable sequences; this also means that the sequence we get is more likely to be the true one,
- F. Using universal sequencing primer sets from priming sites found in most commercial plasmid vectors is convenient and sometimes cheaper.

### 5.2.1. Cloning of the 16S rRNA genes

The recombinant plasmids were isolated from white colonies by the alkaline lysis method (Fig. 14), and the DNA insert was analyzed by restriction digestion using EcoRI (Fig. 15).

The high-copy-number pGEM®-T Easy vector contains a multiple cloning region within lacZ gene coding for the enzyme  $\beta$ -galactosidase and ampicillin resistance gene, which codes for  $\beta$ -lactamase (Promega, 2018).

Successful cloning of an insert into pGEM®-T Easy Vector interrupts the coding sequence of  $\beta$ -galactosidase; recombinant clones can usually be identified by color screening on indicator plates. Blue-white screening provides a convenient and powerful way to distinguish bacterial colonies that contain a cloning vector with a DNA insert (white colonies) from those containing empty vectors with no insert DNA (blue colonies).

Cloning the pGEM®-T Easy vector takes advantage of a phenomenon called  $\alpha$ -complementation of lacZ mutations. The  $\beta$ -galactosidase of *E. coli* K12 JM101 encoded by the lacZ  $\Delta$ M15 gene lacks 31 residues near its N-terminus and is catalytically inactive. N-terminal peptides from  $\beta$ -galactosidase can complement the lacZ  $\Delta$ M15 mutation and restore  $\beta$ -galactosidase activity. This can be resolved by cloning a vector that contains the 5'-end of the lacZ gene, referred to as lacZ $\alpha$ . The lacZ $\alpha$  gene encodes a 146 amino acid peptide from  $\beta$ -galactosidase that complements the lacZ  $\Delta$ M15 mutation (Juers, 2012; Julin, 2018).

The transformed cells were spread on plates in the presence of X-Gal and IPTG. The selection will be made on an ampicillin-containing medium. A lactose analog IPTG induces expression of the lac promoter in the plasmid. Bacterial cells harboring an empty vector in the transformation procedure produce the  $\alpha$ -complementing peptide and thus have active  $\beta$ -galactosidase; as a result, they form blue colonies. The origin of these blue colonies is that IPTG binds and inactivates the lac operon repressor, thereby allowing lac expression. When expressed, the  $\beta$ -galactosidase enzyme catalyzes the hydrolysis of the synthetic substrate X-Gal. Hydrolysis of X-gal produces galactose and 5-bromo-4-chloro-3-hydroxyindole. The latter product undergoes spontaneous dimerization and oxidation to form a blue-colored indigo insoluble pigment (5,5'-dibromo-4,4'-dichloro-indigo). However, DNA ligated into the polylinker prevents  $\alpha$ -peptide production, so cells containing recombinant plasmids form white colonies. A polylinker cloning site is inserted near the 5'-end of the lacZ $\alpha$  coding sequence. Expression of the lacZ $\alpha$  gene from the empty vector produces the complementing peptide. A DNA insert cloned into the polylinker disrupts the lacZ $\alpha$  coding region, so a recombinant plasmid will not have the complementing peptide (Julin, 2018).

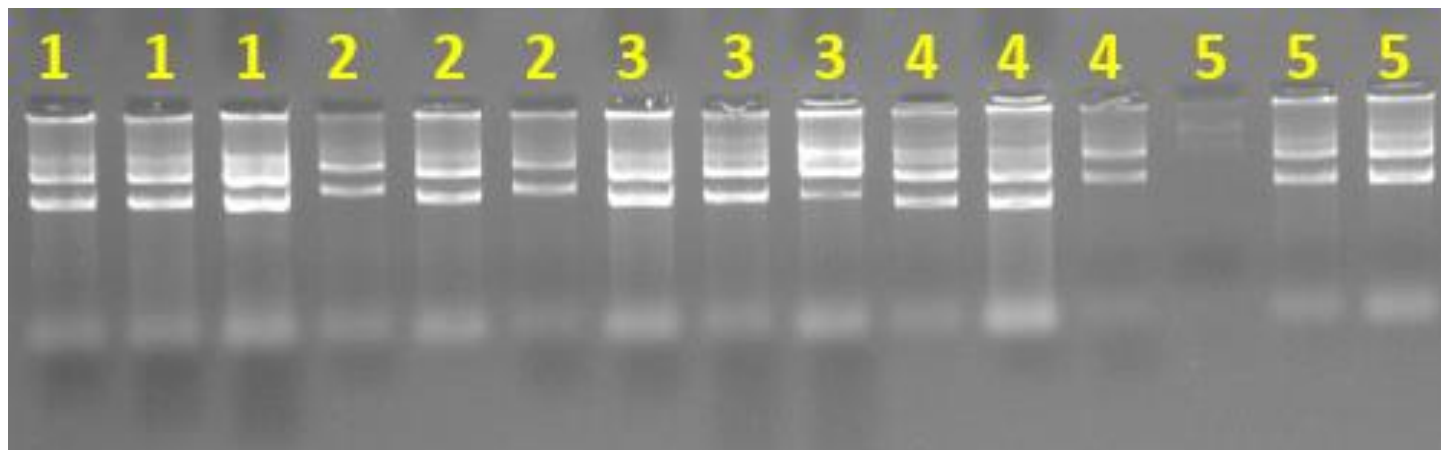

**Figure 14.** Gel electrophoresis of recombinant plasmids isolated from white colonies by the alkaline lysis method (three clones for each strain).

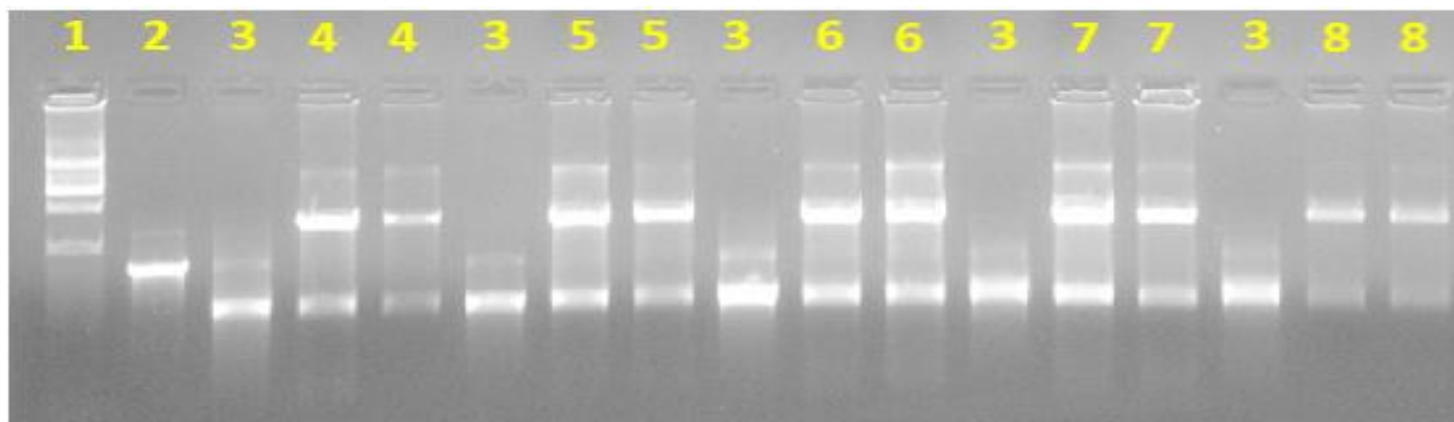

**Figure 15.** Digestion of different 16S rRNA cloned plasmids using EcoRI restriction enzyme. **1:** Undigested plasmid, **2:** PCR product, **3:** Digested PCR product, **4,5,6,7,8:** Digested plasmids (two clones for each strain).

### 5.3. Phylogenetic characterization

Based on SDS-PAGE fingerprinting of whole-cell proteins results combined with physiological and biochemical data, of 293 isolates, 100 bacteria were selected for identification by complete 16S rRNA gene sequencing (>1400pb).

The sequences were analyzed for similarity and aligned with the closest representative sequences, using Blast database (NCBI) and EzTaxon-server. The phylogenetic analysis revealed that the strains were affiliated to 12 different genera grouping 27 distinct species with 96.09 to 100% of sequence similarity to closely related species (Tab. 8). The nucleotide sequences determined in this study have been deposited in the GenBank (NCBI database) under accession numbers from MN885696 to MN885795.

The *Bacillus* genus dominated the thermophilic isolates (30%) with high species diversity: *B. haynesii*, *B. hisashi*, *B. kokeshiiformis*, *B. licheniformis*, *B. paralicheniformis*, *B. sonorensis*, and *B. thermocopriae*. Other research found that *Bacillus* was the most dominant isolated genus from hot springs (Adiguzel *et al.*, 2009; Aanniz *et al.*, 2015). *Anoxybacillus* spp. was ranked in the second position (17%) with seven different species: *A. flavithermus*, *A. geothermalis*, *A. gonensis*, *A. kaynarcensis*, *A. pushchinoensis*, *A. salavatliensis*, and *A. thermarum*.

The genera *Aeribacillus* spp. and *Aneurinibacillus* spp. presented 15% of isolates. The first genus with two species, *A. composti* and *A. pallidus*. Only one species *Ane. thermoaerophilus* was detected for the second one. They were followed by *Brevibacillus* spp. (8%), *Thermoactinomyces* spp. (5%) and *Meiothermus* spp. (3%), with two species, *B. aydinogluensis* and *B. thermoruber*, only one species, *Thermoactinomyces vulgaris* and *Meiothermus ruber*, respectively. A low isolation rate of 2% characterized two genera, *Geobacillus* spp., which was represented by *G. icigianus* and *G. stearothermophilus*, with *Thermus* spp. comprising one species, *T. antranikianii*. Other isolated species, such as *Laceyella sacchari*, *Saccharomonospora viridis*, and *Thermobifida fusca*, represent 1% of the total isolates (Fig. 16 and 17). Yohandini *et al.* (2015) reported that the Genera *Geobacillus*, *Anoxybacillus*, *Brevibacillus*, and *Bacillus* were commonly found in thermal environments, within Tanjung Sakti hot Spring, in South Sumatera, Indonesia, and these results are consistent with our findings.

Moreover, these results also indicate that Algerian hot springs located in the Eastern part of the country harbor a wide variety of thermophilic species, some already known or potentially novel waiting for further identification. Interestingly, this study includes the isolation and

identification of strains belonging to six different genera; *Aneurinibacillus*, *Laceyella*, *Meiothermus*, *Thermus*, *Thermobifida* and, *Saccharomonospora* (Benammar *et al.*, 2020), which have never been reported previously from any hot springs in Algeria (Mokrane *et al.*, 2016; Arab *et al.*, 2018; Gomri *et al.*, 2018).

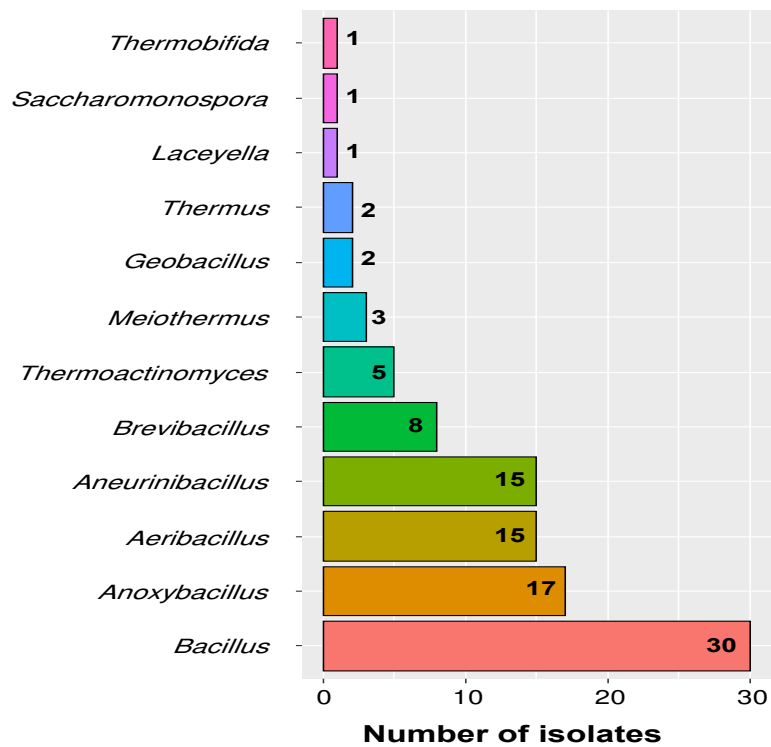

**Figure 16.** The total number of thermophilic isolates for each genus.

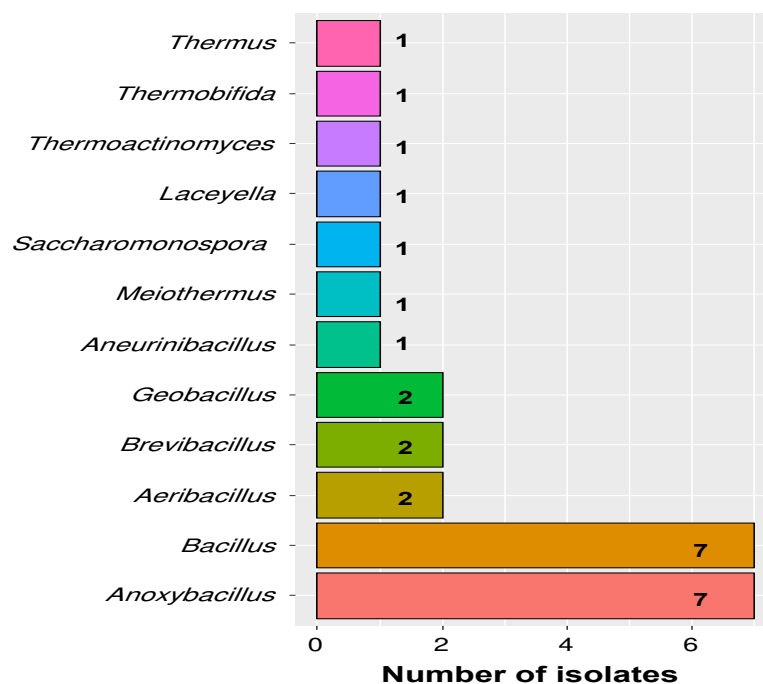

**Figure 17.** The number of distinct species in each isolated genus.

**Table 8.** Thermophilic bacteria isolated from Algerian hot springs and their best match results with typed strains 16S rRNA gene sequences.

Site	Genus	Isolates	Related bacterial strains (Accession Number)	Similarity %
Guerdjima Hot Spring (H05G) N=15	<i>Aeribacillus</i> (n=4)	05G38	<i>A. composti</i> N.8 (LT594972)	99.77
		05G14	<i>A. pallidus</i> KCTC3564 (CP017703)	99.60
		05G30	<i>A. pallidus</i> KCTC3564 (CP017703)	99.82
		05G40	<i>A. pallidus</i> KCTC3564 (CP017703)	99.36
	<i>Aneurinibacillus</i> (n=4)	05G4	<i>A. thermoaerophilus</i> DSM 10154 (X94196)	99.82
		05G7	<i>A. thermoaerophilus</i> DSM 10154 (X94196)	99.86
		05G8	<i>A. thermoaerophilus</i> DSM 10154 (X94196)	99.72
		05G9	<i>A. thermoaerophilus</i> DSM 10154 (X94196)	99.88
	<i>Anoxybacillus</i> (n=3)	05G21	<i>A. gonensis</i> G2 (CP012152)	99.22
		05G27	<i>A. gonensis</i> G2 (CP012152)	99.81
		05G37	<i>A. gonensis</i> G2 (CP012152)	100.0
	<i>Bacillus</i> (n=3)	05G33	<i>B. sonorensis</i> NBRC101234 (AYTN01000016)	99.78
		05G32	<i>B. licheniformis</i> ATCC14580 (AE017333)	99.09
		05G35	<i>B. licheniformis</i> ATCC14580 (AE017333)	99.71
		<i>Thermoactinomyces</i> (n=1)	05G17	<i>T. vulgaris</i> KCTC9076 (AF138739)
Saïda Hot Spring (H05S) N=13	<i>Aeribacillus</i> (n=3)	05S4	<i>A. pallidus</i> KCTC3564 (CP017703)	99.71
		05S8	<i>A. pallidus</i> KCTC3564 (CP017703)	100.0
		05S20	<i>A. pallidus</i> KCTC3564 (CP017703)	99.30
	<i>Anoxybacillus</i> (n=4)	05S29	<i>A. gonensis</i> G2 (CP012152)	99.65
		05S32	<i>A. kaynarcensis</i> D1021 (EU926955)	99.14
		05S15	<i>A. pushchinoensis</i> K1 (jgi.1042845)	99.53
		05S24	<i>A. salavatliensis</i> A343 (EU326496)	99.70
	<i>Bacillus</i> (n=1)	05S9	<i>B. hisashii</i> N-11 (AB618491)	99.40
	<i>Brevibacillus</i> (n=1)	05S37	<i>B. aydinogluensis</i> PDF25 (HQ419073)	99.79
	<i>Meiothermus</i> (n=1)	05S28	<i>M. ruber</i> DSM1279 (CP001743)	100.0
	<i>Thermoactinomyces</i> (n=3)	05S3	<i>T. vulgaris</i> KCTC9076 (AF138739)	99.40
		05S19	<i>T. vulgaris</i> KCTC9076 (AF138739)	99.62
		05S21	<i>T. vulgaris</i> KCTC9076 (AF138739)	98.13
Belhachani Hot Spring (H24A) N=15	<i>Aeribacillus</i> (n=3)	24A34	<i>A. composti</i> N.8 (LT594972)	99.93
		24A13	<i>A. pallidus</i> KCTC3564 (CP017703)	99.50
		24A52	<i>A. pallidus</i> KCTC3564 (CP017703)	99.08
	<i>Anoxybacillus</i> (n=4)	24A10	<i>A. flavithermus</i> DSM2641 (CP020815)	99.04
		24A 3	<i>A. gonensis</i> G2 (CP012152)	99.63
		24A46	<i>A. gonensis</i> G2 (CP012152)	99.81
		24A12	<i>A. thermarum</i> AF/04 (AM402982)	99.28
	<i>Bacillus</i> (n=5)	24A37	<i>B. haynesii</i> NRRLB-41327 (MRBL01000076)	99.78
		24A11	<i>B. kokeshiiformis</i> MO-04 (JX848633)	99.21
		24A 6	<i>B. licheniformis</i> ATCC14580 (AE017333)	99.80
		24A27	<i>B. licheniformis</i> ATCC14580 (AE017333)	99.47
		24A31	<i>B. licheniformis</i> ATCC14580 (AE017333)	99.61
	<i>Laceyella</i> (n=1)	24A21	<i>L. sacchari</i> KCTC9790 (AF138737)	99.25
	<i>Saccharomonospora</i> (n=1)	24A43	<i>S. viridis</i> DSM43017 (CP001683)	99.36
	<i>Thermoactinomyces</i> (n=1)	24A22	<i>T. vulgaris</i> KCTC9076 (AF138739)	99.17

Table 8. Continued

Site	Genus	Isolates	Related bacterial strains (Accession Number)	Similarity %
El Knif Hot Spring (H40K) N=8	<i>Aneurinibacillus</i> (n=4)	40K10	<i>A. thermoaerophilus</i> DSM 10154 (X94196)	99.88
		40K14	<i>A. thermoaerophilus</i> DSM 10154 (X94196)	99.65
		40K15	<i>A. thermoaerophilus</i> DSM 10154 (X94196)	99.88
		40K18	<i>A. thermoaerophilus</i> DSM 10154 (X94196)	99.25
	<i>Anoxybacillus</i> (n=2)	40K 8	<i>A. gonensis</i> G2 (CP012152)	99.03
		40K12	<i>A. gonensis</i> G2 (CP012152)	99.31
	<i>Bacillus</i> (n=1)	40K 1	<i>B. licheniformis</i> ATCC14580 (AE017333)	99.11
<i>Brevibacillus</i> (n=1)	40K19	<i>B. aydinogluensis</i> PDF25 (HQ419073)	99.28	
Essalihine Hot Spring (H40S) N=15	<i>Aeribacillus</i> (n=4)	40S28	<i>A.composti</i> N.8 (LT594972)	99.85
		40S35	<i>A.composti</i> N.8 (LT594972)	99.85
		40S30	<i>A.pallidus</i> KCTC3564 (CP017703)	99.56
		40S42	<i>A. pallidus</i> KCTC3564 (CP017703)	99.24
	<i>Aneurinibacillus</i> (n=6)	40S14	<i>A. thermoaerophilus</i> DSM 10154 (X94196)	98.35
		40S16	<i>A. thermoaerophilus</i> DSM 10154 (X94196)	99.15
		40S23	<i>A. thermoaerophilus</i> DSM 10154 (X94196)	99.69
		40S43	<i>A.thermoaerophilus</i> DSM 10154 (X94196)	99.41
		40S44	<i>A.thermoaerophilus</i> DSM 10154 (X94196)	99.87
		40S45	<i>A. thermoaerophilus</i> DSM 10154 (X94196)	99.88
	<i>Bacillus</i> (n=2)	40S13	<i>B.haynesii</i> NRRLB-41327 (MRBL01000076)	99.78
		40S20	<i>B.licheniformis</i> ATCC14580 (AE017333)	99.61
	<i>Brevibacillus</i> (n=3)	40S24	<i>B. aydinogluensis</i> PDF25 (HQ419073)	99.64
		40S25	<i>B. thermoruber</i> DSM 7064 (Z26921)	99.54
		40S27	<i>B. aydinogluensis</i> PDF25 (HQ419073)	96.81
Sidi El Hadj Hot Spring (H07S) N=15	<i>Anoxybacillus</i> (n=2)	07S31	<i>A. geothermalis</i> GSsed3 (KJ722458)	99.23
		07S16	<i>A. gonensis</i> G2 (CP012152)	99.90
	<i>Bacillus</i> (n=11)	07S24	<i>B. haynesii</i> NRRLB-41327 (MRBL01000076)	99.35
		07S26	<i>B. haynesii</i> NRRLB-41327 (MRBL01000076)	99.78
		07S5	<i>B. hisashii</i> N-11 (AB618491)	99.88
		07S12	<i>B.hisashii</i> N-11 (AB618491)	99.90
		07S14	<i>B. hisashii</i> N-11 (AB618491)	99.52
		07S21	<i>B. hisashii</i> N-11 (AB618491)	99.77
		07S32	<i>B. hisashii</i> N-11 (AB618491)	99.51
		07S20	<i>B. licheniformis</i> ATCC14580 (AE017333)	96.09
		07S27	<i>B. licheniformis</i> ATCC14580 (AE017333)	98.51
		07S13	<i>B. paralicheniformis</i> KJ-16 (KY694465)	99.73
		07S15	<i>B. paralicheniformis</i> KJ-16 (KY694465)	99.52
	<i>Brevibacillus</i> (n=2)	07S11	<i>B. aydinogluensis</i> PDF25 (HQ419073)	99.77
		07S35	<i>B. aydinogluensis</i> PDF25 (HQ419073)	99.48
Guerfa Hot Spring (H24G) N=5	<i>Bacillus</i> (n=3)	24G13	<i>B. haynesii</i> NRRLB-41327 (MRBL01000076)	99.50
		24G 1	<i>B. hisashii</i> N-11 (AB618491)	99.40
		24G17	<i>B. sonorensis</i> NBRC101234 (AYTN01000016)	99.64
	<i>Geobacillus</i> (n=2)	24G 6	<i>G. icigianus</i> G1w1 (KF631430)	98.02
		24G 5	<i>G. stearothermophilus</i> NBRC 12550 (AB271757)	98.79

Table 8. Continued

Site	Genus	Isolates	Related bacterial strains (Accession Number)	Similarity %
Debagh Hot Spring (H24D) N=14	<i>Aeribacillus</i> (n=1)	24D35	<i>A. composti</i> N.8 (LT594972)	99.41
	<i>Aneurinibacillus</i> (n=1)	24D 1	<i>A. thermoaerophilus</i> DSM 10154 (X94196)	99.22
	<i>Anoxybacillus</i> (n=2)	24D20	<i>A. kaynarcensis</i> D1021 (EU926955)	99.41
		24D29	<i>A. kaynarcensis</i> D1021 (EU926955)	99.49
	<i>Bacillus</i> (n=4)	24D46	<i>B. haynesii</i> NRRLB-41327 (MRBL01000076)	99.57
		24D45	<i>B. hisashii</i> N-11 (AB618491)	99.47
		24D 6	<i>B. kokeshiiformis</i> MO-04 (JX848633)	99.41
		24D26	<i>B. thermocopriae</i> SgZ-7 (JX113681)	99.51
	<i>Brevibacillus</i> (n=1)	24D 3	<i>B. aydinogluensis</i> PDF25 (HQ419073)	99.56
	<i>Meiothermus</i> (n=2)	24D25	<i>M. ruber</i> DSM1279 (CP001743)	99.92
		24D28	<i>M. ruber</i> DSM1279 (CP001743)	98.98
	<i>Thermobifida</i> (n=1)	24D39	<i>T. fusca</i> NBRC14071 (BCWB01000075)	99.73
	<i>Thermus</i> (n=2)	24D9	<i>T. antranikianii</i> HN3-7 (Y18411)	99.78
		24D24	<i>T. antranikianii</i> HN3-7 (Y18411)	99.23

To provide a better taxonomic interpretation, BLASTn results were coupled with phylogenetic analysis. The 16S rRNA gene sequences were aligned with those of the closest type species. A phylogenetic tree of the 16S rRNA gene for the collection of thermophilic isolates was constructed by the Neighbor-Joining method to determine the position of each isolate relative to the type strains. The phylogenetic associations of the isolates are presented separately for *Firmicutes: Paenibacillaceae* and *Thermoactinomycetaceae* (Fig.18), *Firmicutes: Bacillaceae* (Fig.19), *Deinococcus-Thermus* and *Actinobacteria* (Fig.20). The strains retrieved from hot springs were distributed over three phyla *Firmicutes* (93%), *Deinococcus-Thermus* (5%) and *Actinobacteria* (2%), six families, and four orders (Tab. 9).

Table 9. Phylogenetic classification of the thermophilic isolates.

Domain	Phylum	Class	Order	Family	Genus
Bacteria	Firmicutes	Bacilli	Bacillales	Bacillaceae	<i>Aeribacillus</i>
					<i>Anoxybacillus</i>
					<i>Bacillus</i>
					<i>Geobacillus</i>
Bacteria	Firmicutes	Bacilli	Bacillales	Paenibacillaceae	<i>Aneurinibacillus</i>
					<i>Brevibacillus</i>
Bacteria	Firmicutes	Bacilli	Bacillales	Thermoactinomycetaceae	<i>Thermoactinomyces</i>
					<i>Laceyella</i>
Bacteria	Deinococcus-Thermus	Deinococci	Thermales	Thermaceae	<i>Meiothermus</i>
					<i>Thermus</i>
Bacteria	Actinobacteria	Actinobacteria	Pseudonocardiales	Pseudonocardiaceae	<i>Saccharomonospora</i>
Bacteria	Actinobacteria	Actinobacteria	Streptosporangiales	Nocardiopsaceae	<i>Thermobifida</i>

Overall, the *Firmicutes* are regrouping three families; *Bacillaceae*, *Paenibacillaceae*, and *Thermoactinomycetaceae*. The members of *Firmicutes* dominated among the bacteria isolated from all sampled hot springs. The results provide evidence that *Bacillus* and related genera; *Aeribacillus*, *Anoxybacillus*, and *Geobacillus* representing the family *Bacillaceae* with 64% of total isolates were ubiquitous and seemed well adapted in this type of environment compared to other groups. This resistance is likely due to the endospore-forming ability of these bacteria representing a successful survival strategy and dominance under high-temperature conditions (Nicholson *et al.*, 2000). Similarly, many reports indicate the abundance of the phylum *Firmicutes* in extreme environments (Sahay *et al.*, 2017).

Several studies have been carried out on thermophilic bacteria's ecology, taxonomy, and phylogeny and, recently, their biotechnological applications. However, to our knowledge, this work is the first test on the isolation of thermophilic bacteria from terrestrial hydrothermal hot spring located in the North-East of Algeria, mainly Saïda (H05S), Guerdjima (H05G), Sidi El Hadj (H07S), El Knif (H40K), Belhachani (H24A), and Guerfa (H24G) hot springs.

The dominance of the *Bacillus*, *Anoxybacillus*, and *Geobacillus* genera has been reported in two hot springs: Ouled Ali and Debagh from Guelma city in Algeria using cultural methods (Gomri *et al.*, 2018). Likewise, Arab *et al.* (2018) reported during a study on the biodiversity of aerobic *Bacilli* using molecular and culture-based approaches in Debagh hot spring the isolation of thermophilic bacterial strains from water samples. The characterization and phylogenetic analysis indicated that the bacterial isolates belonged to four genera (*Bacillus*, *Geobacillus*, *Aeribacillus*, and *Hydrogynophilus*). The latter genus was not detected in this study; maybe it requires targeted strategies to be isolated. Indeed, this genus was isolated on the medium Bushnell-Haas recommended for the microbial examination of fuels and for studying microbial hydrocarbon deterioration. The dominance of *Bacillus* strains (30%) found in our research could be explained by the fact that this genus has been reported to adapt well to environmental stress like high temperature. *Bacillus licheniformis* was the dominant species in this genus (approximately 30% of total strains), agreeing with those obtained by Aanniz *et al.* (2015).

The genus *Aeribacillus* has been found several times in thermophilic environments, mainly deserts, hot springs, and compost (Miñana-Galbis *et al.*, 2010; Aanniz *et al.*, 2015). Currently, this genus includes only two validated species, *A. palludis* KCTC3564 and *A. composti* N.8 (LT594972) (LSPN, 2021). Both were isolated from almost all targeted hot springs (6/8 hot springs) (Tab. 8). The 15 strains identified as *Aeribacillus* showed sequence similarity with the type strains between 100% and 99.08%. Thus, all *Aeribacillus* strains must be further identified by DNA-DNA hybridization, fatty acids, and polar lipid profiles (*in*

progress). Since *Aeribacillus composti* N.8 (LT594972), based on 16S rRNA gene sequence similarities, was most closely related to *Aeribacillus pallidus* strain H12T (=DSM 3670T) with a 99.8% similarity value (Finore *et al.*, 2017).

In the radiation from the Gram-positive genus *Bacillus*, the thermophilic bacterial genera *Anoxybacillus* and *Geobacillus* were discovered. The genus *Geobacillus* includes 23 validly published taxa (LSPN, 2021). Members of this genus are Gram-positive, spore-forming rods, neutrophilic, obligately thermophilic, and aerobic or facultatively anaerobic, comprising the type species *Geobacillus stearothermophilus* (Logan *et al.*, 2015). Only two strains were isolated from Guerfa hot spring (*G. stearothermophilus* 24G5 and *G. icigianus* 24G6). While *G. stearothermophilus* is considered the third thermophilic bacteria isolated from food, it has even been isolated from various hot springs worldwide (Logan *et al.*, 2015). This is the first time we have reported these two species' isolation from thermal springs in Algeria. Arab *et al.* (2018) revealed the isolation of *Geobacillus toebii*, while Gomri *et al.* (2018) that of *Geobacillus thermoleovorans*. 23% of *Firmicutes* were affiliated to *Paenibacillaceae* represented by two genera (*Aneurinibacillus* 15% and *Brevibacillus* 8%), which agrees with the finding of Kumar *et al.* (2014).

In addition, the family *Thermoactinomycetaceae* was also represented by two genera *Thermoactinomyces* and *Laceyella*, with a 6% isolation rate. *Thermoactinomyces* genus currently includes 11 validated species, of which only one species was isolated from sediment samples of a thermal spring in Algeria: Hammam Essalihine in Khenchela City; this is the case of *T. khenchelensis* (Mokrane *et al.*, 2016), while *Laceyella* consists of five validated taxa (LSPN, 2021). Both genera are phylogenetic nearest neighbors. They are thermophilic, aerobic, Gram-stain-positive, non-acid-fast chemoorganotroph. Aerial and substrate mycelia are formed, aerial mycelium is white. Yellow-brown or grayish-yellow soluble pigment may be produced (Goodfellow and Jones, 2015a, 2015b).

Until recently, the genus *Thermoactinomyces* was considered actinomycete, mainly because of its ability to form aerial mycelium when cultured on solid media. However, a variety of taxonomic data; including the ability to produce dipicolinic acid-containing endospores, low G+C content of DNA, menaquinone composition, 5S rRNA and 16S rRNA gene sequences, and comparative ribosomal AT-L30 protein analysis showed that *Thermoactinomyces* were closely related to other endospore-forming bacteria; the *Firmicutes* phylum (Goodfellow and Jones, 2015c).

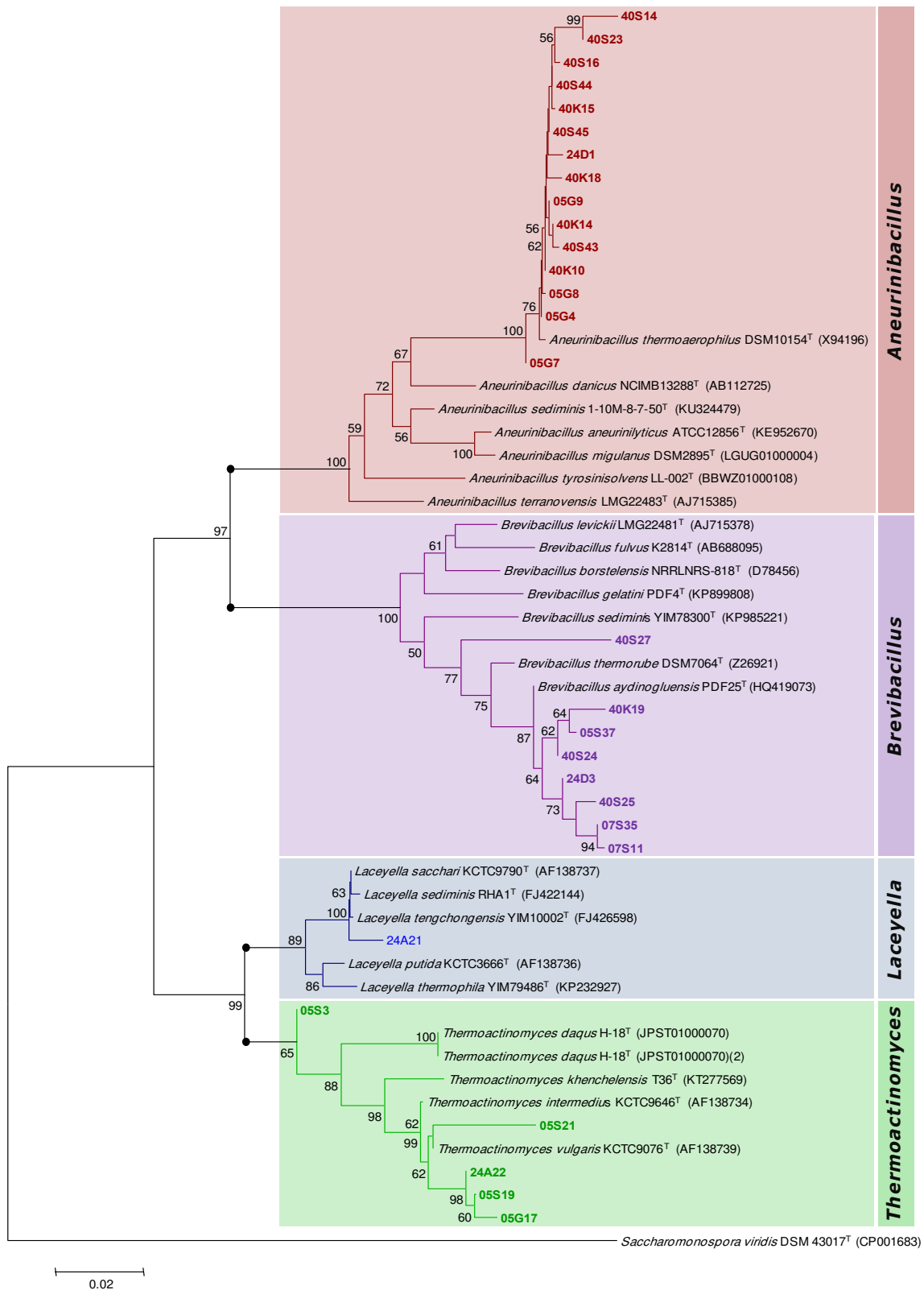

**Figure 18.** Neighbor-joining phylogenetic tree showing the relationship between *Firmicutes* isolates (*Paenibacillaceae* and *Thermoactinomycetaceae*) and closely related species based on 16S rRNA gene sequence comparison. Bootstrap values are expressed as percentages of 1000 replications; only bootstrap values > 50% are shown at nodes. The scale bar represents a 2% estimated sequence divergence.

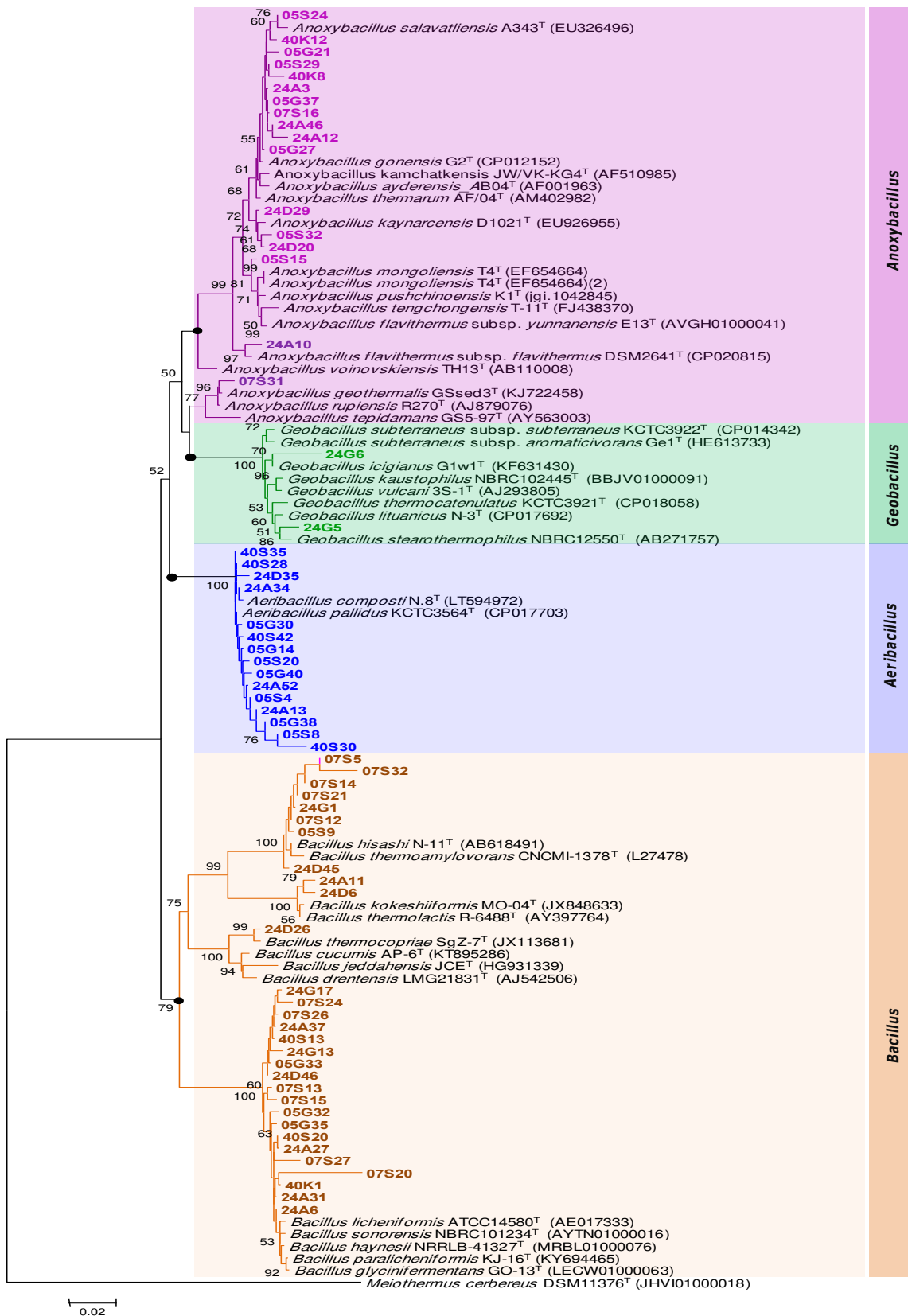

**Figure 19.** Neighbor-joining phylogenetic tree showing the relationship between *Bacillaceae* isolates and closely related species based on 16S rRNA gene sequence comparison. Bootstrap values are expressed as percentages of 1000 replications; only bootstrap values > 50% are shown at nodes. The scale bar represents a 2% estimated sequence divergence.

The Gram-negative bacteria were represented by the *Deinococcus-Thermus* phylum harboring *Meiothermus* (three isolates: 05S28, 24D25, and 24D28) and *Thermus* (two isolates: 24D9 and 24D24). Both genera have so far been isolated from terrestrial hot springs around the world mainly, Yellowstone National Park (USA), Kamchatka (Russia), Iceland, New Zealand, Japan, Central France, Northern Taiwan, and New Mexico (Spanevello and Patel 2004; Tindall *et al.*, 2010a). The genera *Meiothermus* and *Thermus* occur like single species of *M. ruber* and *T. antranikianii* with 98.98 to 100% similarity to closely related species (Tab.9). Both belong to the *Thermales* order and *Deinococci* class (LPSN, 2021).

*Thermus antranikianii* is a strictly aerobic, brightly yellow-pigmented Gram-negative thermophilic heterotroph bacterium. The growth occurs between 50–80 °C; the optimum growth temperature was about 70 °C (Albuquerque *et al.*, 2018a). This genus currently includes 17 validated species (LPSN, 2021). The two strains of *T. antranikianii* (24D9 and 24D24) were isolated from Debagh hot spring (96°C). *Meiothermus ruber* is a Gram-negative red intracellular carotenoid pigmented and slightly thermophilic bacterium, with optimum growth temperatures of 55 °C (Albuquerque *et al.*, 2018b). None of the three strains grow above 70°C. This genus regroups at present nine validated species (LPSN, 2021).

A reduced number of *Actinobacteria* was obtained (2%), considering that none specific culture medium was planned for their isolation. Two genera *Thermobifida* and *Saccharomonospora* were isolated from thermal spring sediments on the *Thermus* medium. The result of 16S rRNA gene amplicon sequencing revealed 99% similarities to closely related species (Tab. 8).

Many researchers reported the actinobacterial diversity in hot springs by culture-independent methods (Lavrentyeva *et al.*, 2018; Law *et al.*, 2020; Roy *et al.*, 2020). However, there are rare reports on culturable actinobacteria in geothermal fields (Liu *et al.*, 2016) because very little is known on actinobacteria's biogeography diversity and distribution in hot springs (Song *et al.*, 2009; Valverde *et al.*, 2012).

In their research, Liu *et al.* (2016) report the diversity of culturable actinobacteria associated with hot springs located in Tengchong, Yunnan Province (Southwestern China), distributed over three geothermal fields. The phylogenetic identification of 58 strains revealed the affiliation to 12 actinobacterial genera: *Actinomadura*, *Micromonospora*, *Microbispora*, *Micrococcus*, *Nocardiopsis*, *Nonomuraea*, *Promicromonospora*, *Pseudonocardia*, *Streptomyces*, *Thermoactinospora*, *Thermocatellispora*, and *Verrucosisspora*, of which the two novel genera *Thermoactinospora* and *Thermocatellispora*. However, during our study, we isolated only two different genera *Thermobifida* and *Saccharomonospora*. The differences in

actinobacterial community composition in hot springs depend on the geographic distance and environmental parameters heterogeneity (Martiny *et al.*, 2011). More research is needed to elucidate the biogeographic patterns and environmental factors that affect the structure of this important group of bacteria in hot springs.

Indeed, on a total of two identified actinobacteria, one isolate of *Saccharomonospora viridis* (24A43) from Belhachani Hot Spring (H24B), and one isolate of *Thermobifida fusca* (24D39) from Debagh Hot Spring (H24D). Both were isolated from Guelma City hot springs where a high temperature was reported, 72°C and 96°C, respectively. Of the total thermophilic bacteria (293 isolates), 45 actinomycetes were isolated (bacteria showing mycelial growth). During this study, we identified phylogenetically 100 bacteria; the remaining number 193, including the 43 actinomycetes, are ongoing identification. The low rate of actinobacterial isolates could be explained by the use of culture media, allowing the growth of many thermophilic non-mycelial bacteria, fast-growing and invasive bacteria (e.g., *Bacillus* and *Aneurinibacillus*), which prevents actinomycetes from growing (Kitouni *et al.*, 2005; Menasria *et al.*, 2019). Thermophilic actinomycetes have a fast growth rate. However, they require a very high concentration of oxygen, which is often a critical factor limiting their growth in hot springs (Mahajan and Balachandran, 2017).

*Saccharomonospora viridis* is a Gram-negative bacterium classified among the Gram-positive actinomycetes, which is the most interesting aspect of this species. The strain is monospore producing and can grow up to 60°C, with an optimum at 55°C (Pati *et al.*, 2009). The bacterium is used in bioremediation as a metabolizing agent of the pentachlorophenol (PCP); a toxic organochlorine compound used as a pesticide and wood preservative (Webb *et al.*, 2001). The genus *Saccharomonospora* currently includes 14 validated species (LPSN, 2021). They are mainly mesophilic actinobacteria except for *Saccharomonospora xinjiangensis* and *Saccharomonospora viridis*, which are thermophilic (Shivlata and Satyanarayana, 2015). The genus belongs to the family of *Pseudonocardiaceae* and the class of *Actinobacteria*. *S. viridis* is the type species of the genus (Nonomura and Ohara, 1971).

Regarding the *Thermobifida* genus, which including only four species (LPSN, 2021). The isolated *Thermobifida fusca* is a Gram-positive moderately thermophilic actinobacteria belonging to the *Nocardiopsaceae* family (Zhang *et al.*, 1998), which is knowing for producing a wide range of enzymes for industrial use such as; cellulase, xylanase, cutinase, and glucose isomerase (Wei *et al.*, 2014). According to our results, the isolated strain *Thermobifida* (24D39) was positive toward all tested enzymes.

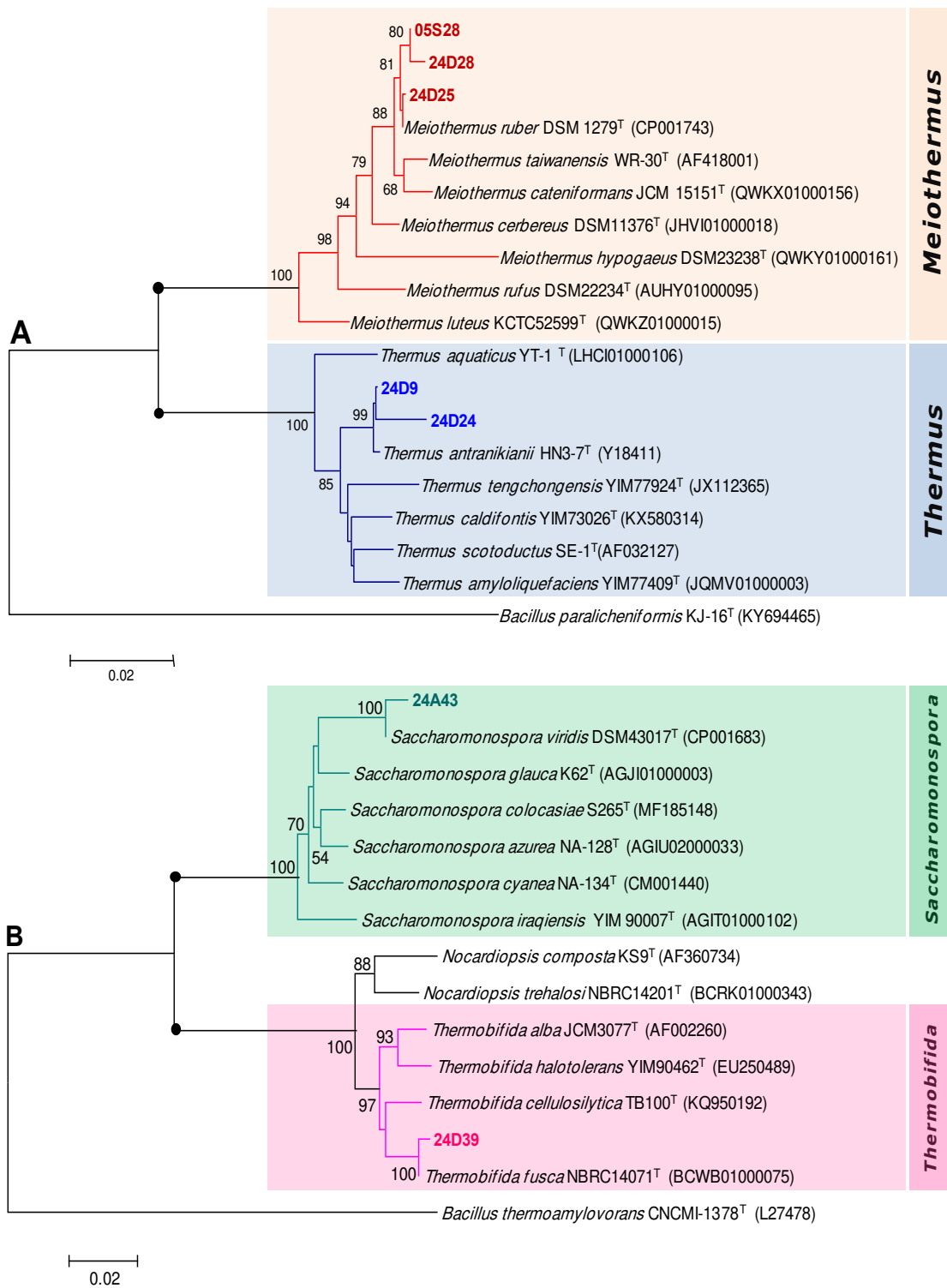

**Figure 20.** Neighbor-joining phylogenetic tree showing the relationship based on 16S rRNA gene sequence comparison of (A) *Deinococcus-Thermus*, (B) *Actinobacteria*. Bootstrap values (expressed as percentages of 1000 replications) greater than 50% are shown at nodes. The scale bar represents a 2% estimated sequence divergence. The sequence of *Bacillus thermoamylovorans* was used as an outgroup.

The culture techniques used to analyze bacterial diversity can give only a restricted view or a rough approximation of the natural diversity. They allow access to each organism individually and therefore are marred by inherent errors in cultivation methods. According to several authors, between 0.001% and 15% of the prokaryotes present in a sample can be cultivated using conventional techniques (Kirk *et al.*, 2004). This discrepancy can be attributed to different causes:

- (i) The chosen culture medium cannot be universal,
- (ii) All the existing environmental conditions cannot be reproduced on the same culture medium, in particular for environments with strong physicochemical gradients,
- (iii) Outside their environment, some microbial cells may enter a viable but non-cultivable state (VBNC),
- (iv) Populations enriched in broth may not develop on solid media,
- (v) The amount of chosen inoculum influences the type of cells enriched and cultured,
- (vi) Different microorganisms having similar growth conditions will be difficult to distinguish, and
- (vii) Some cells are impossible to obtain in pure cultures, like symbionts and syntrophic microorganisms (Overmann *et al.*, 2017).

The traditional methods, including morphological, physiological, and biochemical characterization (Fig. 23) used for preliminary classification of the isolates, are troublesome, uncertain, difficult for interpretation, and may involve substantial subjective judgment. In contrast, SDS-PAGE results allow clustering the isolates enabling rapid and easy discrimination as the first step for mandatory molecular identification.

Indeed, the probably new strains were classified in three clusters: the strain 07S27 in Cluster I-A, the strain 40S14 in cluster I-B, and the remaining bacteria in cluster II-C. The SDS-PAGE of whole-cell proteins and subsequent 16S rRNA gene sequence analysis can be an interesting tool for prospecting and identifying new strains of thermophilic bacteria. This method could help reduce redundant clones during the bioprospecting process since it is easy to perform without complex or expensive equipment, especially when many samples require screening.

The 16S rRNA gene sequencing contributes to identifying the strains successfully to genus and even to species level based on their genotypic characteristics. Although 16S rRNA gene sequencing is highly accurate and useful regarding bacterial classification, it may be insufficient to distinguish between closely related species and has low discriminatory power for

some genera (Janda and Abbott, 2007). This is the case for species within some genera like; *Bacillus*, *Anoxybacillus*, *Aeribacillus*, and *Geobacillus* (Zeigler and Perkins, 2008; Goh *et al.*, 2014; Burgess *et al.*, 2017).

Thus, the identification of bacteria, and specifically thermophiles, could benefit from the addition of other fingerprinting methods for strain and species discrimination as Rep-PCR (Adiguzel *et al.*, 2009), ARDRA analysis (Kikani *et al.*, 2015), PCR RFLP of ITS (Sen *et al.*, 2015), *rpoB* and *flaA* gene sequencing (Inan *et al.*, 2011a; Colak *et al.*, 2012), and BOX-PCR (Meintanis *et al.*, 2008).

The limit of traditional culture-based methods to describe the enormous diversity existing in the hidden microbial world has forced us to currently shift towards culture-independent approaches of metagenomics which complement physiological analyses to a quite effective exploring functional and taxonomic diversity in hot springs (López-López *et al.*, 2013; Panda *et al.*, 2018).

#### 5.4. Sequencing results of probably novel species

The Blast analysis of the 16S rRNA gene sequence indicates that seven strains confirming the affiliation to *Bacillus*, *Brevibacillus*, *Geobacillus*, *Aneurinibacillus*, and *Thermoactinomyces* may probably constitute new taxa on these genera. These sequences have been deposited in GenBank under the following accession numbers (Tab.10).

**Table 10.** Probably novel species description information and the similarity frequency with the type strain. Saïda (H05S) Guerdjima (H05G), Sidi El Hadj (H07S), Essalihine (H40S), El Knif (H40K), Debagh (H24D), Belhachani (H24A), Guerfa (H24G).

City	Hot springs	Isolates	Related bacterial strains	GenBank accession number	Similarity (%)
Biskra	H07S	07S20	<i>Bacillus licheniformis</i> ATCC14580	MN885731	96.09
	H07S	07S27	<i>Bacillus licheniformis</i> ATCC14580	MN885735	98.51
Khenchela	H40S	40S27	<i>Brevibacillus aydinogluensis</i> PDF25 (HQ419073)	MN885788	96.81
	H40S	40S14	<i>Aneurinibacillus thermoaerophilus</i> DSM 10154	MN885782	98.35
Guelma	H24G	24G6	<i>Geobacillus icigianus</i> G1w1	MN885770	98.02
	H24G	24G5	<i>Geobacillus stearothermophilus</i> NBRC 12550	MN885769	98.79
Batna	H05S	05S21	<i>Thermoactinomyces vulgaris</i> KCTC9076	MN885718	98.13

Further, six isolates (07S20, 07S27, 40S27, 40S14, 24G6, and 05S21) exhibited <98.51% nucleotide sequence similarity with reported type strains in the NCBI and EzTaxon servers. This value was lower than 98.65%; the similarity threshold of 16S rRNA gene sequence required to differentiate two bacterial species and describe a new species without performing the DNA–DNA hybridization (Kim *et al.*, 2014). The phylogenetic tree was constructed as before using the MEGA6 software (Tamura *et al.*, 2013). The isolate's position and their relation to the appropriate genera type strains have been reported in figures 21 and 22.

Among the potentially novel taxa, the strains 07S20 and 07S27 showed sequence similarity with the type strain *Bacillus licheniformis* KCTC9076 of 96.09% and 98.51%, respectively (Tab. 11,12). The strain 05S21 revealed 98.13% sequence similarity with the species *Thermoactinomyces vulgaris* KCTC9076 (Tab. 13). The two strains 24G6 and 24G5 exhibited 98.02% and 98.79% similarity with the species *Geobacillus icigianus* G1w1(T) and *Geobacillus stearothermophilus* NBRC 12550(T) respectively (Tab. 14,15). The strain 40S27 indicated the highest sequence similarity with *Brevibacillus aydinogluensis* PDF25(T) (96.81%) (Tab. 16). While the strain 40S14 showed the highest 16S rRNA gene sequence similarity with the type strain *Aneurinibacillus thermoaerophilus* DSM 10154(T) (98.35%) (Tab. 17).

The two strains 07S20 and 07S27 showed sequence similarity with the type strain *Bacillus licheniformis* KCTC9076 of 96.09% and 98.51%, respectively. However, they are probably not the same strains since the sequences produce significant alignments with 95.60% similarity, and even some dissimilarities were reported among biochemical and physiological characteristics.

These strains need to be further characterized by G+C content, fatty acids, and polar lipid analysis (*in progress*). The results obtained indicate that the probable new species belonged to four different hot springs among the eight prospected and covers the four cities chosen for the study, which explains the richness of Algerian thermal springs in new taxa.

Previous studies describe novel species isolated from different Algerian terrestrial geothermal sites, mainly represented by *Pyrococcus* sp. HT3 from El Biban hot spring; Bordj Bou-Arréridj City (Kecha *et al.*, 2007), *Caldicoprobacter algeriensis* and *Caldicoprobacter guelmensis* from Debagh hot spring; Guelma City (Bouanane-Darenfed *et al.*, 2011, 2013); and *Thermoactinomyces kenchelensis* from Essalihine hot spring; Khenchela City (Mokrane *et al.*, 2016).

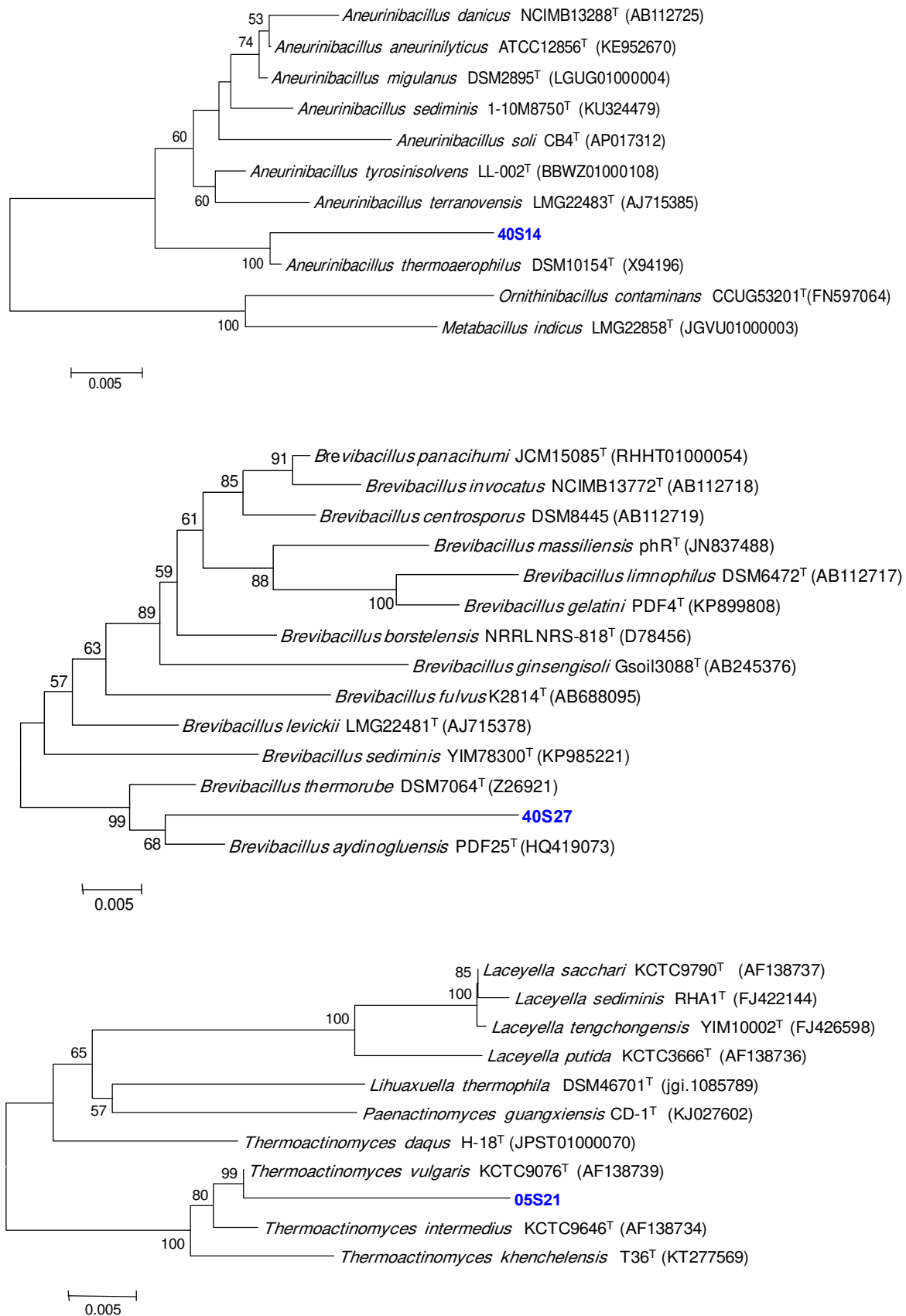

**Figure 21.** Phylogenetic trees based on the sequence analysis of the gene encoding 16S rRNA showing the relationships between the 40S14, 40S27, and 05S21 strains with the type species of the closest genera.

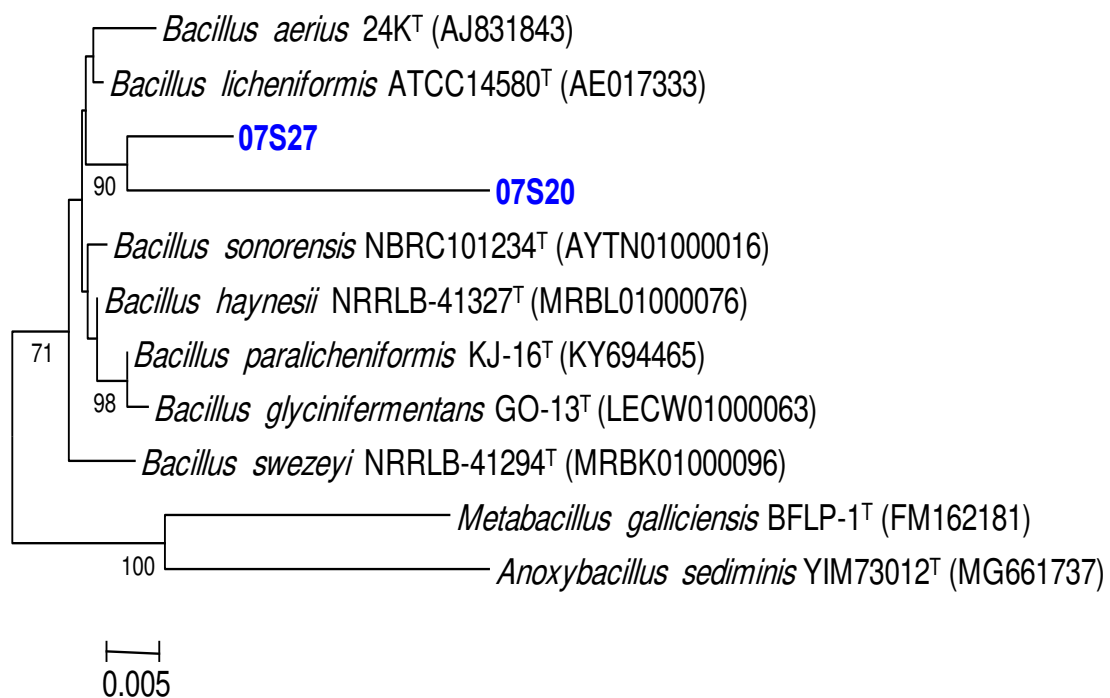
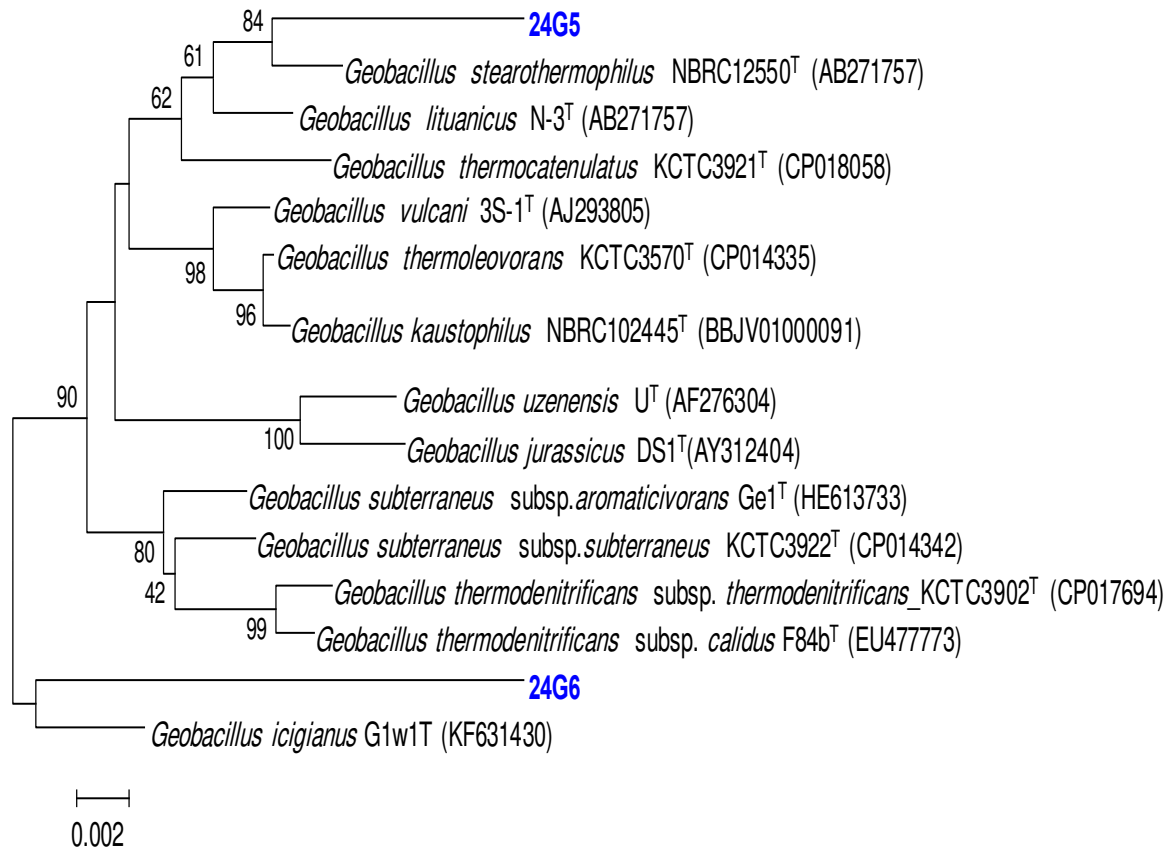

**Figure 22.** Phylogenetic trees based on the sequence analysis of the gene encoding 16S rRNA showing the relationships between the 24G5, 24G6, 07S27, and 07S20 strains with the type species of the closest genera.

**Table 11.** BLAST result of the 16S rRNA gene sequence of the strain 07S20 with the type strains of the species belonging to the genus *Bacillus*

Bacteria	Strains	Accession N°	Similarity	Difference (Nc/tot)
<i>Bacillus licheniformis</i>	ATCC 14580(T)	AE017333	<b>96,09</b>	41/1049
<i>Bacillus sonorensis</i>	NBRC 101234(T)	AYTN01000016	96,00	42/1049
<i>Bacillus haynesii</i>	NRRL B-41327(T)	MRBL01000076	95,61	42/1049
<i>Bacillus paralicheniformis</i>	KJ-16(T)	KY694465	95,51	46/1049

**Table 12.** BLAST result of the 16S rRNA gene sequence of the strain 07S27 with the type strains of the species belonging to the genus *Bacillus*

Bacteria	Strains	Accession N°	Similarity	Difference (Nc/tot)
<i>Bacillus licheniformis</i>	ATCC 14580(T)	AE017333	<b>98,51</b>	16/1076
<i>Bacillus haynesii</i>	NRRL B-41327(T)	MRBL01000076	98,42	17/1076
<i>Bacillus sonorensis</i>	NBRC 101234(T)	AYTN01000016	98,23	19/1076
<i>Bacillus paralicheniformis</i>	KJ-16(T)	KY694465	98,05	21/1076
<i>Bacillus aerius</i>	24K(T)	AJ831843	97,95	22/1074

**Table 13.** BLAST result of the 16S rRNA gene sequence of the strain 05S21 with the type strains of the species belonging to the genus *Thermoactinomyces*

Bacteria	Strains	Accession N°	Similarity	Difference (Nc/tot)
<i>Thermoactinomyces vulgaris</i>	KCTC9076	AF138739	<b>98,13</b>	26/1390
<i>Thermoactinomyces intermedius</i>	KCTC 9646(T)	AF138734	97,55	34/1390
<i>Thermoactinomyces khenchelensis</i>	T36(T)	KT277569	96,04	55/1390
<i>Thermoactinomyces daqus</i>	H-18(T)	JPST01000070	94,66	74/1386

**Table 14.** BLAST result of the 16S rRNA gene sequence of the strain 24G5 with the type strains of the species belonging to the genus *Geobacillus*

Bacteria	Strains	Accession N°	Similarity	Difference (Nc/tot)
<i>Geobacillus stearothermophilus</i>	NBRC 12550(T)	AB271757	<b>98,79</b>	13/1076
<i>Geobacillus lituanicus</i>	N-3(T)	CP017692	98,70	14/1076
<i>Geobacillus subterraneus subsp. subterraneus</i>	KCTC 3922(T)	CP014342	98,23	19/1075
<i>Geobacillus thermocatenulatus</i>	KCTC 3921(T)	CP018058	98,05	21/1075

**Table 15.** BLAST result of the 16S rRNA gene sequence of the strain 24G6 with the type strains of the species belonging to the genus *Geobacillus*

Bacteria	Strains	Accession N°	Similarity	Difference (Nc/tot)
<i>Geobacillus icigianus</i>	G1w1(T)	KF631430	<b>98,02</b>	19/1030
<i>Geobacillus vulcani</i>	3S-1(T)	AJ293805	97,18	29/1030
<i>Geobacillus kaustophilus</i>	NBRC 102445(T)	BBJV01000091	97,09	30/1030
<i>Geobacillus subterraneus subsp. aromaticivorans</i>	Ge1(T)	HE613733	97,09	30/1030
<i>Geobacillus thermoleovorans</i>	KCTC 3570(T)	CP014335	96,99	31/1030
<i>Geobacillus thermocatenulatus</i>	KCTC 3921(T)	CP018058	96,89	32/1030

**Table 16.** BLAST result of the 16S rRNA gene sequence of the strain 40S27 with the type strains of the species belonging to the genus *Brevibacillus*

Bacteria	Strains	Accession N°	Similarity	Difference (Nc/tot)
<i>Brevibacillus aydinogluensis</i>	PDF25(T)	HQ419073	<b>96,81</b>	41/1033
<i>Brevibacillus thermoruber</i>	DSM 7064(T)	Z26921	95,84	42/1033
<i>Brevibacillus levickii</i>	LMG 22481(T)	AJ715378	94,46	42/1011
<i>Brevibacillus sediminis</i>	YIM 78300(T)	KP985221	93,91	46/1018
<i>Brevibacillus borstelensis</i>	NRRL NRS-818(T)	D78456	93.42	67/1018

**Table 17.** BLAST result of the 16S rRNA gene sequence of the strain 40G14 with the type strains of the species belonging to the genus *Aneurinibacillus*

Bacteria	Strains	Accession N°	Similarity	Difference (Nc/tot)
<i>Aneurinibacillus thermoaerophilus</i>	DSM 10154(T)	X94196	<b>98,35</b>	13/1010
<i>Aneurinibacillus sediminis</i>	1-10M-8-7-50(T)	KU324479	94,74	40/1010
<i>Aneurinibacillus danicus</i>	NCIMB 13288(T)	AB112725	94,15	46/1010
<i>Aneurinibacillus migulanus</i>	DSM 2895(T)	LGUG01000004	93,40	52/1010

#### 5.4.1. Physiological and biochemical characters

The results of the physiological and biochemical characterization of the selected strains are shown below:

- ❖ **The strain 07S20** can grow in rich culture media up to 10% (w/v) salt concentration, with a growth optimum of 7.5% (w/v) (halotolerant strain). It has been found that the bacteria can tolerate temperature variations of 37 to 65 °C with an optimum of 38 to 40 °C. The pH range allowing the strain 04S20 growth is between 6.0 and 8.5, with a growth optimum of 7 to 7.5, and can therefore be considered a neutrophil. The carbohydrate assimilation test was positive for glucose, mannitol, inositol, sorbitol, and amygdalin. The enzymes  $\beta$ -galactosidase, arginine dihydrolase, and urease were produced. The strain has the following hydrolytic activities amylase, gelatinase, pectinase, Dnase, and esculinase, but not lipase, cellulase, and protease.
- ❖ **The strain 07S27** is halotolerant and can grow up to 10% (w/v) of total salts concentration, with a growth optimum of 8 % (w/v). The strain can tolerate variations in temperature from 37 to 65 °C and pH from 5.5 to 9.0 with the optimum at 40 °C and pH 7.5. Unlike the strain 07S20, the 07S27 isolate may assimilate only the inositol as a sole carbon and energy source. Arginine dihydrolase and urease were positive. The bacteria produce gelatinase, caseinase, pectinase, DNase, esculinase, and cellulase.

- ❖ **The strain 40S27** growth was tolerated over a temperature range of 37 °C to 65°C, with the optimum at 55°C, and from pH 5.5 to 8.5. The strain can grow up to 2.5% (w/v) of total salts concentration. It assimilates glucose, mannitol, and arabinose. The bacteria are capable of degrading tween 20, tween 80, lecithin, gelatin, and casein.
- ❖ **The strain 40S14** growth occurs in the presence of 7% (w/v) salt concentration, with a growth optimum of 2.5% (w/v). The strain can tolerate temperature variations of 37 to 65 °C with an optimum of 50 °C. The pH range allowing the growth of 40S14 is between 5.5 and 9, with a growth optimum of 8 to 8.5. All the API20E tests were negative. It was already reported that few carbohydrates are assimilated, and acid is produced weakly in some *Aneurinibacillus* strains (Logan and Vos, 2015). This strain produces lipase, lecithinase, and caseinase.
- ❖ **The strain 24G5** grows from 35°C to 65°C with an optimum at 55°C, and from pH 5 to 9. It can tolerate up to 10% (w/v) of salt concentration. Usually, NaCl and KCl are not required, and most strains will grow on routine media such as nutrient agar (Logan *et al.*, 2015). The isolate cannot assimilate any carbohydrate tested. The strain hydrolyzes lecithin, starch, pectin, cellulose, casein, and gelatin.
- ❖ **The strain 24G6** can grow up to 5% (w/v) salt concentration. The strain can tolerate temperature variations of 35°C to 65°C with an optimum at 55°C, and from pH 5.5 to 8, with an optimum at 7.5. All the API20E tests were negative. This strain produces lipase, amylase, pectinase, cellulase, and Dnase.
- ❖ **The strain 05S21** is halotolerant and can grow up to 2.5% (w/v) of total salts concentration, with a growth optimum of 8 % (w/v). The strain can tolerate variations in temperature from 40 to 65 °C and pH from 5.5 to 9.0, with the optimum at 55 °C and pH 7.5. This strain was unable to assimilate any of the carbon substrates of the API E system. The isolate may hydrolysis casein, gelatin, tween 20, tween 80, and lecithin.

Although phylogenetic analysis has the potential to consider novel species, the polyphasic taxonomic approach is necessary. Relatedness studies, including chemotaxonomic analyses, phenotypic profiles characteristics, and biochemical reactivity of the isolates, are highly recommended to describe novel bacterial species (Tindall *et al.*, 2010b; Kämpfer and Glaeser 2012).

## 6. Biochemical characterization

Interestingly, the only media capable of supporting the growth of the totality of the isolates was the Thermus medium, so for comparative purposes, this medium was used to grow the isolates for further characterization.

A total of 182 isolates (62.12%) were catalase-positive, 71 isolates (24.23%) were oxidase-positive, while 16.72% (49 isolates) were oxidase and catalase-positive.

The API 20E profiles of the isolates demonstrated biochemical diversity (Fig. 23). All strains were negative for indole and H<sub>2</sub>S production. As one can see, the utilization of carbohydrates varies; negative assimilation results were obtained overall strains for rhamnose and saccharose. The carbohydrate assimilation test was positive for 20% of strains on amygdalin and inositol, 18% for mannitol, and 15% for glucose, sorbitol, and arabinose. Only 8% assimilate melibiose. The number of positive tests displayed by the isolates ranged from one to ten tests. Around 32% of strains were positive only for one character.

The constructed UPGMA dendrogram of the biochemical characteristics of the selected 100 bacterial strains isolated from eight hot springs showed three clusters (numbered from I to III). Overall, all the isolates displayed a minimum similarity coefficient of approximately 0.68 or displayed phenotype profiles that were about 68% similar. A group of 14 isolates belonging to the eight hot springs formed cluster I. Three isolates from the sub-cluster (IA) showed identical biochemical profiles; isolates 05S28, 24D28, and 24D25 identified by 16S rRNA sequencing as *Meiothermus ruber*, ditto isolates 07S13 and 07S15 identified as *Bacillus paralicheniformis* from sub-cluster (IB). Cluster II was a mixture of 10 isolates from six different sites, exhibiting similar profiles for 40S24, 24D3, 05S37 and, 07S35 attributed to *Brevibacillus aydinogluensis*. Finally, cluster III grouped 76 isolates into two sub-clusters, IIIA harboring six isolates and IIIB gathering 70 isolates. They corresponded to many strains *Anoxybacillus gonensis*, *Geobacillus icigianus*, *Aneurinibacillus thermoaerophilus*, and *Brevibacillus aydinogluensis*.

The biochemical characterization has certain limitations in the classification of isolates, as it is hard to distinguish closely related bacteria. Molecular identification is more reliable and could assist in the definitive identification of isolates as part of a polyphasic taxonomic approach (Singh *et al.*, 2010).

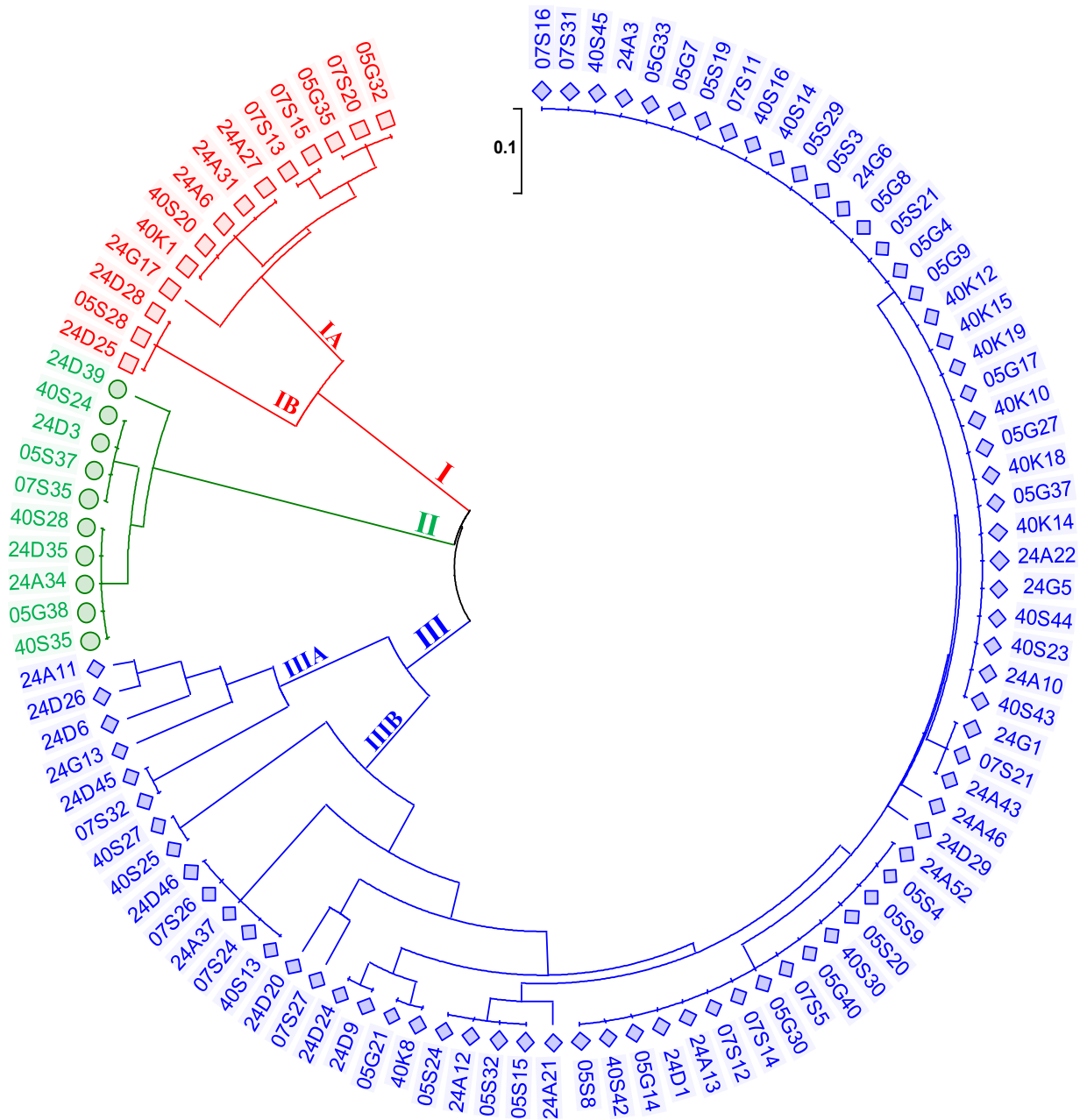
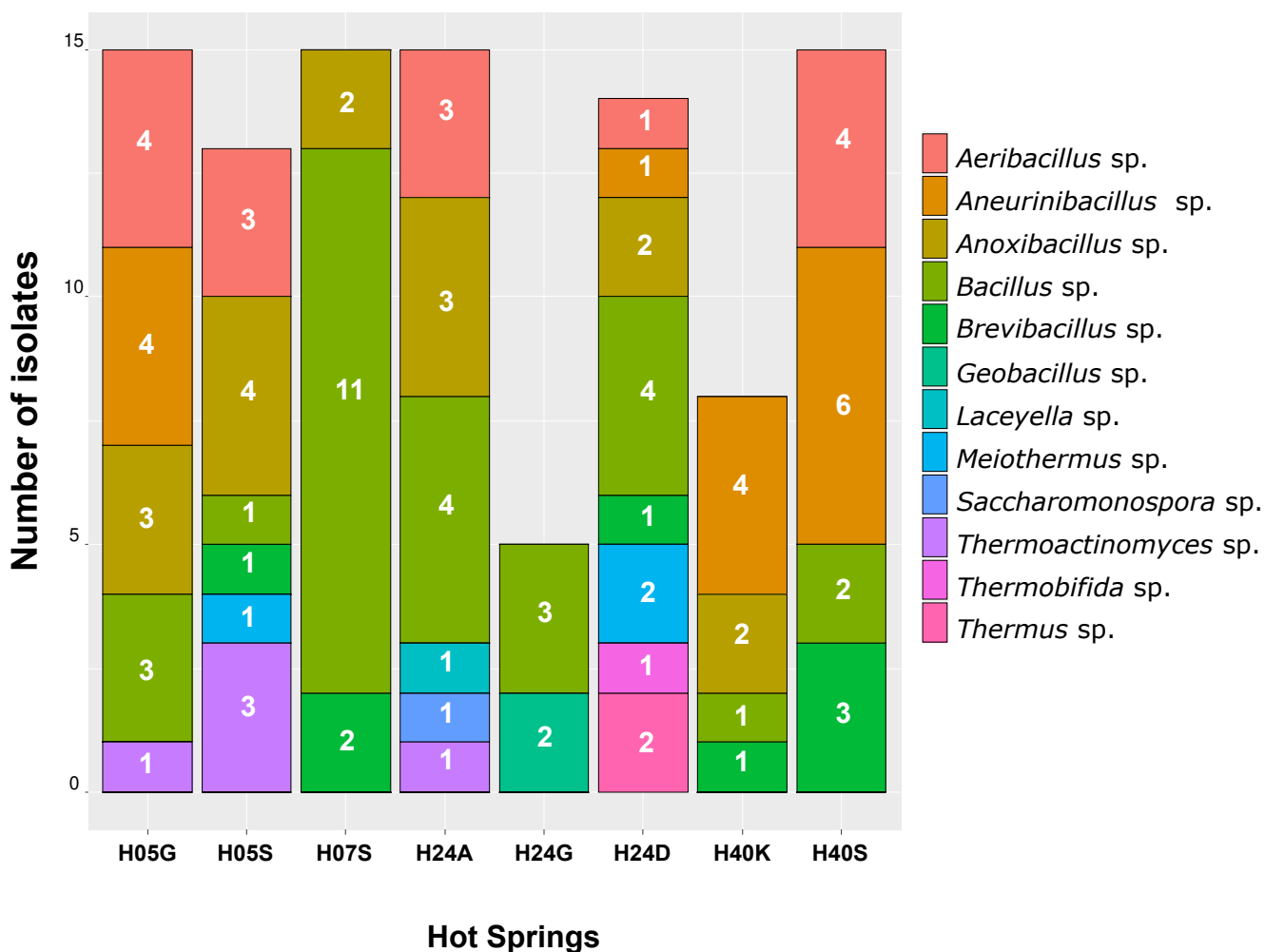

**Figure 23.** Dendrogram of API 20E profiles from thermophilic bacteria isolated from hot springs based on UPGMA cluster analysis and the Jaccard similarity coefficient. The scale bar represents 10% divergence.

## 7. Thermophilic bacterial diversity and evenness

Comparison of the thermophilic bacterial composition of the surveyed samples revealed differences in the diversity structure from one biotope to another, and their nature becomes clear upon analysis.

Among the different sites, Debagh hot spring (H24D) and Belhachani hot spring (H24A) presented the highest species richness (S), with its isolates being closely related to 11 species. The second position of more diverse sites belonged to Saïda hot spring (H05S) with nine represented genera, followed by Guerdjima hot spring (H05G), Sidi El Hadj hot spring (H07S), and Essalihine hot spring (H40S) with seven genera for each site. Guerfa hot spring (H24G) and El Knif hot spring (H40K) resulted in five and four genera, respectively (Fig. 24).



**Figure 24.** The number of thermophilic isolates from the different hot springs. Saïda (H05S) Guerdjima (H05G), Sidi El Hadj (H07S), Essalihine (H40S), El Knif (H40K), Debagh (H24D), Belhachani (H24A), Guerfa (H24G).

The genus *Bacillus* (30%) was isolated from all sampled geothermal sites in the current study. 7% of isolates represented by *Geobacillus*, *Laceyella*, *Saccharomonospora*, *Thermobifida*, and *Thermus* were uniquely distributed in the different hot springs. The other genera were distributed variably. *Aeribacillus*, *Aneurinibacillus*, *Anoxybacillus*, and *Brevibacillus*, were isolated from five hot springs, while *Thermoactinomyces* and *Meiothermus* were cultured from three and two sites, respectively. At each sampling point of the four studied areas, we determined exclusive species (detected at a single sampling point) and common species (found in at least two sampling points). The Venn diagram illustrates that Guelma's hot springs were more diverse than the other sites in terms of species exclusivity, hosting ten exclusive species. The analysis revealed that three species were shared among all locations, whereas one to four other species were classified as common species for the different combinations of regions (Fig. 25).

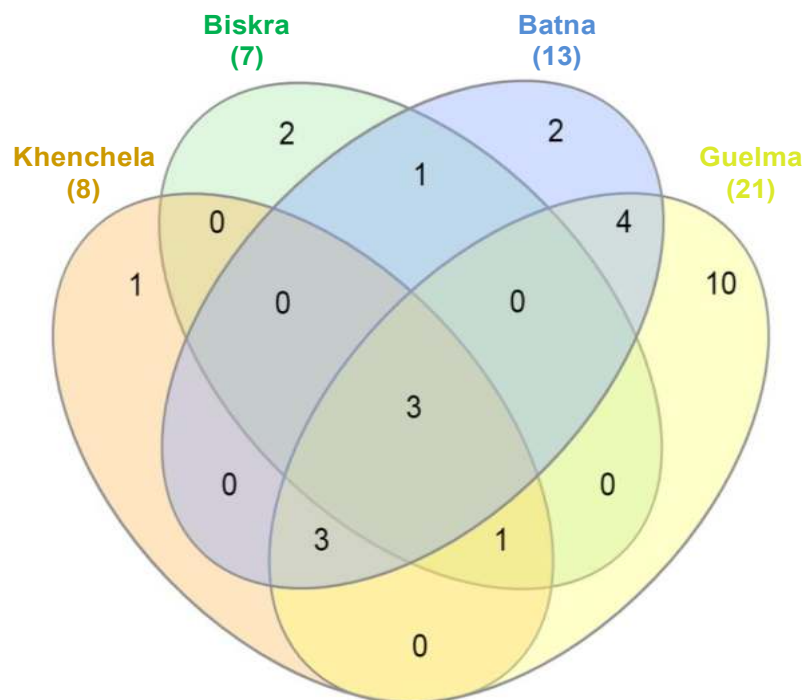

**Figure 25.** Venn-diagram distribution illustrates the number of exclusive and common thermophilic bacterial isolates among the sampled sites. Each ellipse represents a sampling city point.

The Shannon index is commonly used to characterize the species diversity in a community, complementing species richness and evenness. Simpson's index of diversity ( $D_1$ ) represents the probability that two individuals randomly selected from a sample will belong to different species. This index ranges between 0 and 1; the greater the value, the greater the sample diversity (Morris *et al.*, 2014). The mean number of isolated species, Shannon indices, and evenness for each sampling site showed the highest biodiversity at H24D ( $H' = 2.34$ ), H24A

( $H'=2.30$ ) and H05S ( $H'=2.06$ ) hot springs compared to the others sites, while the heterogeneous distribution of the relative abundances of species, represented by evenness index, was 0.98, 0.96 and 0.94 respectively. The bacterial communities presented the lowest diversity at H40K ( $H'=1.21$ ). The reported low value of the Shannon index indicates uneven species distribution in these particular sites (Tab. 18).

The hot springs belonged to Guelma and Batna cities were the most diversified with ( $H'=3.00$  and  $H'=2.30$ ) respectively. Both water and sediment samples harbored almost the same and high level of diversity based on Shannon and Simpson indices; according to the Sørensen index, they shared up to 51.42% of their bacterial species.

The effective number of species (ENS) was calculated to reinforce the estimates of species diversity using the previous indices. ENS presents the number of species in an equivalent community composed of equally abundant species. In the case of a perfectly even community, ENS is equal to species richness (S). This was the case of the H05G hot spring, from which five isolates were assigned to five different species. For uneven communities, ENS was always smaller than species richness (S).

**Table 18.** Species richness and diversity of identified thermophilic bacteria in surveyed hot springs (N, number of bacterial isolates; S: species richness; H: Shannon's index; E: evenness, ENS: effective number of species,  $D_1$ : Simpson index,  $D_2$ : Simpson Dominance index, H05S: Saïda, H05G: Guerdjima, H07S: Sidi El Hadj, H40S: Essalihine, H40K: El Knif, H24D: Debagh, H24A: Belhachani, and H24G: Guerfa.

Sites	<i>N</i>	<i>S</i>	<i>N/S</i>	<i>H'</i>	<i>E</i>	<i>ENS</i>	<i>D<sub>1</sub></i>	<i>D<sub>2</sub></i>	
Sample sites (Hot springs)	H40K	8	4	2,00	1.21	0.87	3.35	0.66	2.90
	H40S	15	7	2,14	1.71	0.88	5.53	0.77	4.41
	H07S	15	7	2,14	1.80	0.93	6.05	0.81	5.23
	H05S	13	9	1,44	2.06	0.94	7.85	0.85	6.76
	H05G	15	7	2,14	1.81	0.93	6.11	0.82	5.49
	H24D	14	11	1,27	2.34	0.98	10.38	0.90	9.80
	H24A	15	11	1,36	2.30	0.96	9.97	0.89	9.00
	H24G	5	5	1,00	1.61	1.00	5.00	0.80	5.00
Sample sites (Regions)	Khenchela	23	8	2.88	1.78	0.86	5.93	0.76	4.23
	Biskra	15	7	2.14	1.80	0.93	6.05	0.81	5.23
	Batna	28	13	2.15	2.30	0.90	9.97	0.88	8.17
	Guelma	34	22	1.55	3.00	0.97	20.09	0.95	18.65
Sample types	Water	45	17	2.65	2.49	0.88	12.06	0.88	8.54
	Sediment	55	19	2.89	2.76	0.94	15.80	0.93	13.94

The traditional microorganism culture approaches have been useful in determining pure cultures' biochemical and physiological properties and developing whole-cell applications. The number of colonies produced on plates, on the other hand, is much less than the number of cells visualized by microscopy (Urbietta *et al.*, 2015). Furthermore, thermophiles that are easily cultivable may not be representative of the natural microbiota. *Bacillus*, *Aneurinibacillus*, *Anoxybacillus*, *Geobacillus*, and *Aeribacillus* have been the most frequently isolated genera from Algerian hot springs in our laboratory (Benammar *et al.*, 2020); however, these genera represent a minority of those present (results from chapter 2).

Common manipulations performed on growth conditions, such as adjusting the media nutrient compositions, pH, incubation temperatures, or the levels of certain gases, can increase the number of different isolates obtained; however, fastidious thermophiles would almost certainly be missed. Several researchers have examined the causes of 'unculturability.'

Several factors can limit the growth of thermophiles in culture, including:

- (i) A naturally slow growth rate,
- (ii) The inhibition is caused by antibacterial substances generated by other cells in the community,
- (iii) The inhibition caused by growth media components,
- (iv) The inhibition caused by agar,
- (v) A lack of quorum-sensing or beneficial interactions and signals,
- (vi) The stringent chemical requirements, and
- (vii) An over-concentration of the supplied nutrients (Urbietta *et al.*, 2015).

As an example, carbon monoxide (CO) is used by some thermophiles (Techtmann *et al.*, 2009), but it is rarely used in laboratory growth conditions due to its toxicity to humans. Furthermore, most hyperthermophiles thrive in anaerobic or facultative anaerobic environments. Anaerobic microorganisms are more difficult to culture than aerobic microorganisms. *Candidatus* bacteria are yet to be isolated and cultured in the laboratory. Garcia-Costas *et al.* (2012) explained the difficulty of *Candidatus* bacteria growth, including the requirement for other helper strains in addition to its slow doubling time and stringent growth conditions such as high partial pressure of CO<sub>2</sub>.

## 8. Hydrolytic enzymes analysis

Due to their extreme adaptation, thermophilic bacteria have attracted the scientific community's attention due to their ability to produce active enzymes, exopolysaccharides antimicrobials, and biosurfactants with potential applications in biotechnology (Mahajan and Balachandran, 2017; Kumar *et al.*, 2019; Wang *et al.*, 2019).

The total 293 bacterial isolates collected from hot springs were screened for different extracellular enzymes, mainly; amylase, cellulase, pectinase, esculinase, protease, gelatinase, lipase, lecithinase, and nuclease activity (Fig. 26, Fig. 27). The frequency occurrence of nine extracellular hydrolytic enzymes produced by thermophilic bacteria of hot springs was shown. 143 isolates (48.81%) produced amylase, 156 isolates (53.24%) had protease, 122 isolates (41.64%) produced lecithinase, 197 isolates (67.24%) reduced CMC-cellulose, 174 isolates (59.39%) produced pectinase enzyme, 200 isolates (68.26%) produce nuclease, 143 isolates (48.81%) produced esculinase, 189 isolates (64.50%) produce lipase, and 173 isolates produced (59.04%) gelatinase.

Among the 293 thermophilic bacteria, 99.32% produced at least one extracellular hydrolytic enzyme. The combined hydrolytic activity was also detected in most strains. Indeed, 19 isolates (6.48%) combined all tested enzymes. Jointly 18.43% (54 isolates) and 15.36% (45 isolates) produced respectively four and six hydrolytic enzymes simultaneously. In addition, 65.87% of isolates have at least five enzymes (Fig. 26).

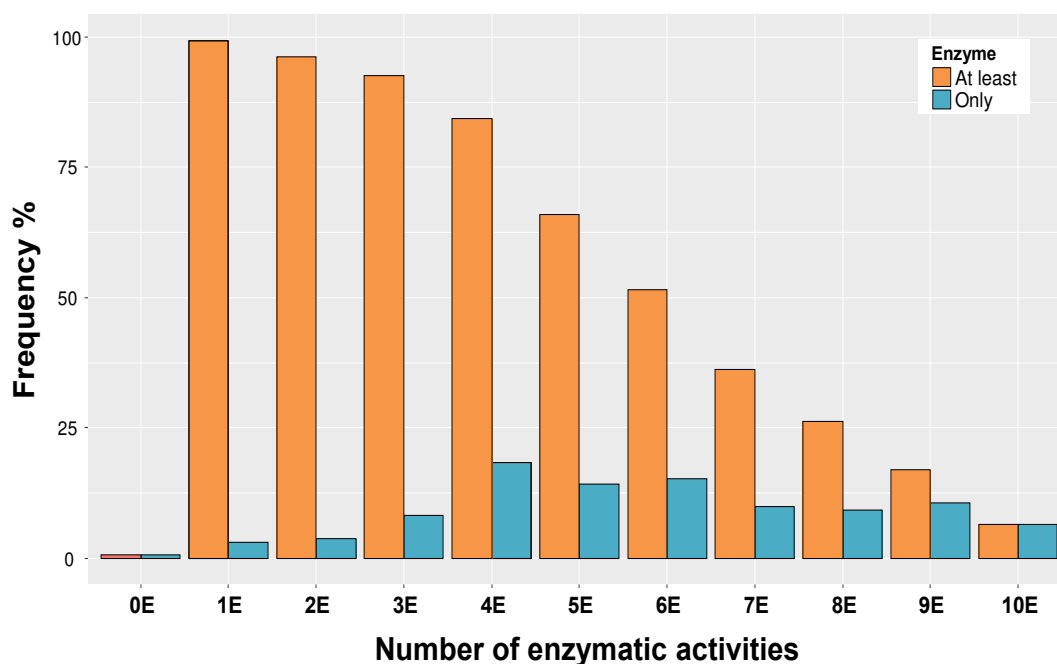

**Figure 26.** Frequency distribution of hydrolytic enzymes among the thermophilic strains.

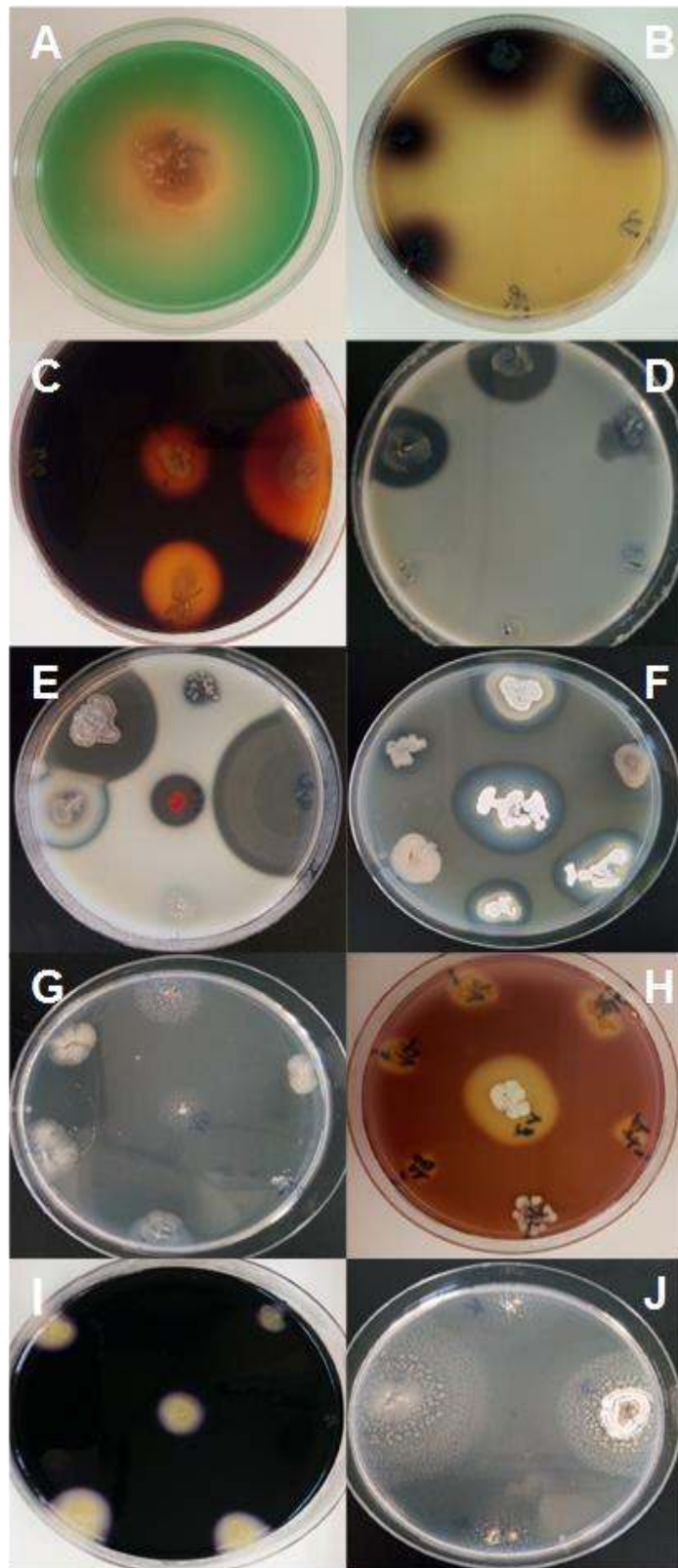

**Figure 27.** Screening of hydrolytic enzymes production by typical thermophilic bacteria isolated from Algerian hot springs. **A.** Dnase; **B.** Esculinase; **C.** Cellulase; **D.** Gelatinase; **E.** Protease, **F.** Lecithinase; **G.** Tween 20 hydrolysis; **H.** Pectinase; **I.** Amylase; **J.** Tween 80 hydrolysis.

The ecological studies on Algerian hot springs led to the isolation and identification of a large number of thermophilic bacteria capable of producing a mixture of mentioned enzymes (Gomri *et al.*, 2018; Benammar *et al.*, 2020). These strains may be valuable for biotechnological purposes.

Previous studies worldwide have shown that thermophilic bacteria from hot springs can produce several hydrolytic enzymes (Khelil and Cheba, 2014; Archna *et al.*, 2015; Sahay *et al.*, 2017; Kumar Neelam *et al.*, 2019).

The enzymes from mesophilic microorganisms are notorious for their instability, leading to the use of temperature-lowering techniques raising the cost. Furthermore, the slow hydrolysis caused by the enzymatic treatment at 50°C results in a low yield (incomplete hydrolysis). Thermozyms offer unique temperature, chemical, and pH stability resulting in a technological interest in diverse industrial applications, including food, pharmaceutical, chemical, paper, textile processing, biofuel production, pulp, and waste-treatment industries (Han *et al.*, 2019).

On the other hand, thermophiles bacteria are a good source of novel catalysts suggesting new applications or improving the existing industrial interest (Niehaus *et al.*, 1999). Some are already being purified, and their genes are successfully cloned in mesophilic hosts (Sevim *et al.*, 2017; Ay Sal *et al.*, 2019).

The most diverse and abundant functional groups were strains with cellulase, lipase, gelatinase, and DNase activities. In the present study, the predominant isolates were belonging to the members of the *Firmicutes* (mainly members of families *Bacillaceae* and *Paenibacillaceae*) such as *Bacillus* and *Bacillus*-like genera: *Anoxybacillus*, *Aeribacillus*, and even *Aneurinibacillus* genus (Fig. 28), known for their significant production of enzymes (Haki and Rakshit, 2003; Goh *et al.*, 2013). Recently, the isolation and screening of thermophilic extracellular enzymes from Hammam Ouled Ali and Hammam Debagh revealed a predominance of proteolytic activity (Gomri *et al.*, 2018).

Recently, many novel enzymes were described; xylanase XynA3 and XynM1 enzymes from the sediment of the Lobios Hot Spring in Spain and Tattapani geothermal field of Chhattisgarh, India, respectively (Knapik *et al.*, 2019; Joshi *et al.*, 2020). Lipase Lip479 from Tattapani hot spring in India (Sahoo *et al.*, 2020), cytochromes P450 from the Binh Chau hot spring in Vietnam (Nguyen *et al.*, 2020), and type I pullulanase Pul<sub>M</sub> from Reshi thermal spring of the Sikkim Himalayas (Thakur *et al.*, 2021).

Nevertheless, 65 isolates showed cellulolytic activity, including 25 *Bacillus*, 16 isolates of *Anoxybacillus*, seven *Aeribacillus*, and four isolates of *Aneurinibacillus* and *Brevibacillus*, respectively. Gelatinase activity was found in 66 species, and DNase activity in 64 strains.

However, amylase and esculinase activities were noted less frequently than the other hydrolytic activities, with respectively 46% and 39% of the total identified strains (Fig. 28).

Likewise, [Yasir et al. \(2018\)](#) studied the diversity of thermophilic bacteria producing different hydrolases from a hot spring in Saudi Arabia, concluding that *Bacillus* was the dominant genus with high-level enzyme production, including respective protease, lipase, and amylase.

In general, cellulase is of particular interest because cellulose is the most available and renewable biological carbon resource on the planet. In nature, cellulases from bacteria and fungi hydrolyze crystalline cellulose into oligosaccharides, then hydrolyzed into glucose by at least three forms of cellulolytic enzymes, namely endo-1,4- $\beta$ -D-glucanase, cellobiohydrolases, and  $\beta$ -glucosidase ([Archna et al., 2015](#)).

In recent years, current knowledge about cellulase production and challenges in cellulase research has received much attention, particularly in improving the economic process of various industries. Cellulolytic enzymes have been commonly used in various industries, including food, textiles, paper, animal feeds, brewing, and agriculture ([Kuhad et al., 2011](#)).

In recent years, the push to produce second-generation biofuel from lignocellulosic biomass has sparked increased interest in cellulase production ([Harnvoravongchai et al., 2020](#)). Besides their use for biofuel production, cellulases are used in the textile industry for cotton softening and denim finishing and in the detergent market for color treatment, drying, and anti-redeposition in washing powders ([Archna et al., 2015](#)).

Considering thermophile lipases are thermostable and resistant to chemical denaturation by organic solvents, they are predicted to play an essential role in industrial processes. Lipases have various applications in chemicals, detergents, wastewater treatment, food additives, cosmetics, paper and pulp conditioning, pharmaceuticals, and leather industries ([Ovando-Chacon et al., 2020](#)). A variety of lipases have been purified and characterized from moderately thermophilic isolates, mostly *Bacillus* spp. ([Sharma et al., 2018](#)). The lipolytic enzyme systems of extreme thermophiles, particularly those from totally anaerobic bacteria, are nonetheless little understood ([Royter et al., 2009](#)).

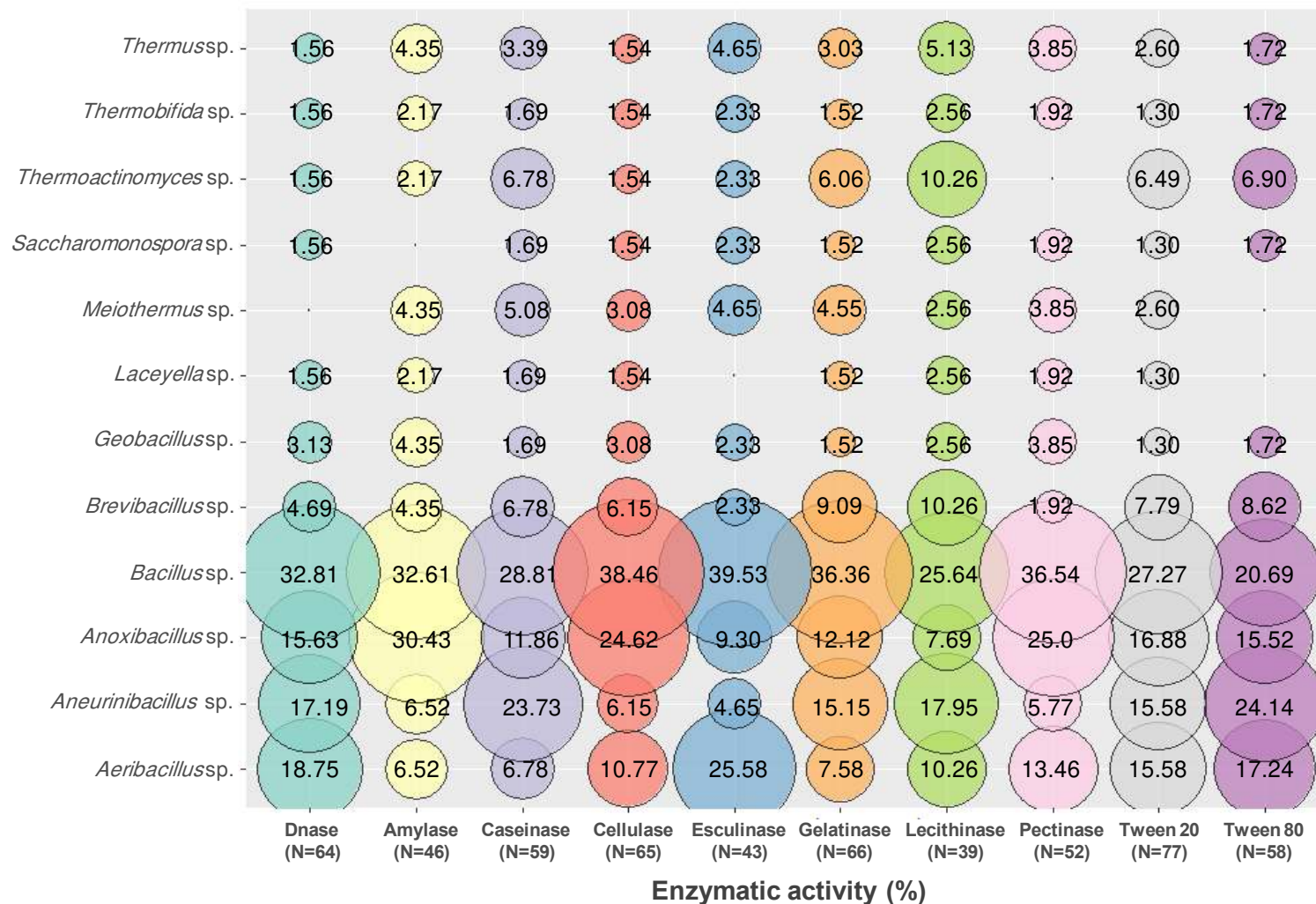

**Figure 28.** Distribution of extracellular hydrolytic enzymes from isolated thermophilic bacteria. (N: the number of isolates presents activities for each enzyme).

*Bacillus* spp. were the highest producers of all targeted enzymes ranging between (20.69% and 39.53%). Indeed, *Bacillus* species are considered workhorse industrial bacteria in applied and industrial microbiology due to their high growth rate and ability to secrete a large volume (20-25 g/L) of extracellular enzymes. Besides, some species are GRAS “generally regarded as safe” (Schallmey *et al.*, 2004).

According to our findings, up to 28.81% of protease and 32.61% of amylase were produced by *Bacillus* (Fig. 28). *Bacillus* proteases have several remarkable characteristics and make up approximately 60% of worldwide enzyme sales (Contesini *et al.*, 2018). Different bacterial species can produce  $\alpha$ -amylase, but for commercial applications, it is mainly proceeding from the genus *Bacillus* (de Souza and de Oliveira Magalhães, 2010).

Our results show the highest rate of 30.43% for amylase activity produced by the *Anoxybacillus* species. From this genus, several new amylases with different properties were identified and characterized. Viksø-Nielsen *et al.* (2006) reported a new  $\alpha$ -amylase that hydrolyzes raw starch granules. *Anoxybacillus* spp. was found to produce many hydrolytic enzymes (amylase, protease, phosphatase, and ribonuclease) and several important wastewater bioremediation enzymes like catalase-peroxidase, superoxide dismutase, and azoreductase (Jardine *et al.*, 2018).

The *Geobacillus* and *Anoxybacillus* members can be used in whole-cell applications as well as biofuel and chemical production via engineered cells. One of the key benefits of employing bacteria from these taxa is that they grow fast, are less contaminated, and are easier to maintain (Mohamad, 2018). *Geobacillus* and *Anoxybacillus* isolated from various hot springs have much potential as biocatalysts for industrial biotechnology. These bacteria have been classified among the most critical enzyme producers due to their ability to create various extracellular enzymes such as amylases, lipases, xylanases, proteases, esterases, and ureases (Satyanarayana *et al.*, 2012).

Regarding *Aneurinibacillus* spp. tween 80 hydrolysis, caseinase, lecithinase, and DNase activities were ranked first among common hydrolases over the strains screened, with 24.14%, 23.37%, 17.95%, and 17.19%, respectively. According to the list of prokaryotic names with standing in nomenclature (LPSN) database, there are now eight validly named *Aneurinibacillus* species, though additional unidentified species have been recorded (LPSN, 2021).

*Aneurinibacillus* spp. has shown the ability to produce secondary metabolites (SMs), promising biosurfactants as well as a variety of enzymes activities. These characteristics make

them promising industrial candidates and exhibit potential environmental applications (Kamli *et al.*, 2021).

The Gram-positive thermophilic bacteria from various hot springs had higher hydrolytic activity than Gram-negative bacteria. However, the Gram-negative *Thermus*-like are major producers of thermozyms. Despite all the interest in hyperthermophilic organisms being exploited biotechnologically, *Thermus aquaticus* generates one of the most valuable enzymes in scientific and economic aspects; the Taq polymerase (Da Costa *et al.*, 2006). According to our results, the isolated *Thermus* strains produced all enzymes, while *Meiothermus* produced eight enzymes, except for Dnase and tween 80 hydrolases.

# CONCLUSION

## CONCLUSION

The present chapter aimed to culture-dependent the diversity of the thermophilic bacteria from terrestrial geothermal springs in Eastern Algeria, using conventional taxonomic methods, SDS-PAGE fingerprinting of whole-cell proteins combined with molecular approaches.

High culturable taxonomic diversity was observed in Algerian hot springs, including probably many novel species belonging mainly to the genera *Bacillus*, *Geobacillus*, *Brevibacillus*, *Aneurinibacillus*, and *Thermoactinomyces*.

A total of 293 strains were isolated from the hot springs water and sediment using different culture media. Overall, five distinct bacterial groups were characterized by whole-cell protein pattern analysis. Based on the 16S rRNA gene sequencing of 100 selected strains, the isolates were assigned to three major phyla: *Firmicutes* (93%), *Deinococcus-Thermus* (5%), and *Actinobacteria* (2%), which included 27 distinct species belonging to 12 different phylotypes: *Aeribacillus*, *Aneurinibacillus*, *Anoxybacillus*, *Bacillus*, *Brevibacillus*, *Geobacillus*, *Laceyella*, *Meiothermus*, *Saccharomonospora*, *Thermoactinomyces*, *Thermobifida*, and *Thermus*.

The *Firmicutes* represented the most dominant group with 93 strains, comprising three families *Bacillaceae*, *Paenibacillaceae*, and *Thermoactinomycetaceae*, which group different genera, notably *Bacillus* (30%), *Anoxybacillus* (17%), followed by *Aeribacillus* and *Aneurinibacillus* with 15%, and *Brevibacillus* (8%).

The screening for nine extracellular hydrolytic enzymes showed that 65.87% of the isolates presented at least five types of enzyme activities, and 6.48% of strains combined all tested enzymes (amylase, cellulase, pectinase, esculinase, protease, gelatinase, lipase, lecithinase, and nuclease). It was found that *Bacillus*, *Anoxybacillus*, *Aeribacillus*, and *Aneurinibacillus* were the genera showing the highest activities. Likewise, Nonetheless, several thermophilic bacteria with the potential to generate thermostable enzyme variants remain unexplored.

The statistical approaches explained the bacterial diversity in terms of the species richness and evenness in the distribution of thermophilic community. Noticeably, these isolates exhibit promising sources of hydrolytic enzymes serving various industrial, agricultural, and medicinal purposes, especially that expose optimal activities at high temperatures.

# CHAPTER II

*Culture Independent Assessment  
of Microbial Diversity and  
Geochemistry of Two Algerian Hot  
Springs*

# INTRODUCTION

## INTRODUCTION

The hot springs are high-temperature aquatic ecosystems broadly distributed throughout the world and serving the development of thermophilic and hyperthermophilic microorganisms (Li and Ma, 2019). Each hot spring has exclusive geophysical and chemical components making these environments hot spots regarding microbial diversity, which is attractive as a source of novel metabolites and hydrolytic enzymes for biotechnological purposes (Kumar *et al.*, 2019).

Analysis of physicochemical factors and phylogenetic diversity data revealed and identified the relation and effect of environmental parameters on the microbial community's diversity in the hot springs and the prevalence of major physiological groups of microorganisms (Sharma *et al.*, 2020).

Various studies about hydrothermal springs, microbial molecular ecology, and diversity were performed worldwide (Bhandari and Nailwal, 2020). The incapacity to culture almost all microorganisms with the culture-dependent methods due to the difficulty of providing in-vitro conditions similar to the original environment boosts the research towards alternative approaches. To overcome limitations of the conventional classic culture-based methods to access microbial diversity has been extended many folds by several techniques, including DGGE, PLFA, and the culture-independent approach of metagenomics (Panda *et al.*, 2018).

Metagenomics, also known as environmental genomics, investigates the composition and functional characterization of mixed microbial communities from ecological sites and allows for identifying both culturable and nonculturable bacteria. Metagenomics results in the description of several novel species as well as novel gene(s) encoding important enzymes and metabolites of biotechnological interest (López-López *et al.*, 2013).

There are over 240 thermal springs located mainly in the Eastern part of Algeria (Saibi, 2009). These hot springs are primarily known for their therapeutic values, where they are used as baths (Hamman) (Fekraoui and Kedaid, 2005); however, only 80 are exploited (Boukhenfouf and Boucenna, 2019). Of the 240 hot springs, quite a few have been explored for microbial biodiversity investigations (Amarouche-Yala *et al.*, 2014; Benammar *et al.*, 2020). Just 25 geothermal sites have prospected microbiologically using culture-dependent techniques, and only two have been explored with cutting-edge metagenomic approaches (Gomri *et al.*, 2018; Adjeroud *et al.*, 2020).

Selected thermal springs were located in two different cities (Guelma and Batna) in the East of Algeria. Both hot springs were formed due to tectonic activities since they belong to the unstable Alpine structural domain (Saïbi, 2009). The major interest related to the choice of these two thermal springs consists in the fact that Debagh hot spring is perceived as an extreme environment, with 98°C is considered as the hottest terrestrial hydrothermal site in Algeria and the second in the world (Stambouli *et al.*, 2012; Boukhenfouf and Boucenna, 2019). However, Saïda hot spring reaches a temperature of 62°C. This study provided the first insight into the physicochemical conditions and microbial community diversity by metagenomics approaches in that spring and even in Batna city. Based on the results from the first chapter, both hot springs presented the highest thermophilic diversity among all the prospected sites.

The present chapter deal with the analysis of critical physicochemical parameters of hot spring's water and aims to investigate and compare the unexplored associated microbial community living abundance and diversity along the two hydrothermal springs in Algeria; Saïda hot spring located in Batna city and Debagh Hot spring in Guelma city, using a culture-independent approach; the next-generation sequencing (Illumina, MiSeq), as well as to identify the most relevant environmental factors influencing community-level diversity shifts at different spatial scales.

# CHAPTER II

## *Materials and Methods*

### 1. Site description and samples collection

The samples were collected from two Northeastern Algerian hot springs: Saïda and Debagh. *Saïda hot spring* located in N'gaous, about 80 km West of Batna City (35°34'03''N5°33'46''E), at an elevation of 682 m (Fig. 1). This source has been exploited since 2015 for the creation of a Spa. The spring water temperature reaches 63°C with a flow rate of 18 l/s (MTATF, 2015).

*Hammam Debagh*, also called Hammam Meskhoutine (meaning bath of the damned) or Hammam Chellala (meaning: bath of waterfalls); a thermal spa located 15 km from the City of Guelma (36° 27'34 " N 7°16'10"E) in North-Eastern Algeria, at an elevation of 306 m. It is the only source in the country that counts nine fountains classified as hyperthermal, with a temperature ranging between 72°C and 98°C, ranking it the hottest hot spring in Algeria. For most fountains, the spring water has a high flow rate of 80 to 100 l/s (Boukhenfouf and Boucenna, 2019).

From each hot spring, triplicate samples of water and sediment were collected. Water samples were collected aseptically in sterilized 500 ml glass bottles with screw top lids. Approximately 500 g of wet sediment samples were collected and placed in polypropylene screw cap containers by scooping using a sterile sampling spoon. For chemical analysis, water samples of 1000 ml were collected from each hot spring in new borosilicate glass bottles with Teflon caps treated with 1/10 diluted nitric acid, rinsed with distilled water, and later washed with the sample's water (Rodier *et al.*, 2016). All samples were preserved at 4°C immediately after sampling and transported to the laboratory for further analysis.

### 2. Analysis of environmental parameters

The *in-situ* parameters were measured by using (i) the portable multiparameter meter model (Hanna HI 8314), the following parameters were recorded: temperature (°C) and pH values, (ii) the portable conductivity meter model (Hanna HI-8733) for measuring conductivity ( $\mu\text{s}/\text{cm}$ ) and (iii) salinity refractometer for determining salinity.

The probes were rinsed using distilled water before measuring and then placed directly in the hot spring water source for the *in-situ* measurements. The geographical coordinate for each sampling site was also taken using the GPS (GARMIN 72H).



**Figure 1.** Location map of the sampled sites Debagh hot spring (Guelma) and Saïda hot spring (Batna) (Google Earth Pro v7.3.2, Accessed March 2021). **A-B-C:** Debagh Hot Spring, **D-E:** Saïda Hot Spring.

### 2.1. Total alkalinity

The titration method was used to determine total alkalinity, which measures the capacity of water to neutralize acids ([Appendix 6\\_Section1\\_](#)). Total alkalinity is measuring the amount of acid needed to bring the sample to a pH of 4.2 in the presence of a colored indicator. At this pH, all the alkaline compounds in the specimen are "used up." The result is reported as milligrams per liter of calcium carbonate (mg/L CaCO<sub>3</sub>) ([APHA, 2018](#)).

### 2.2. Total hardness

The total hardness (TH) was determined by the EDTA titrimetric method. This method allows the rapid determination of calcium and magnesium ions ([Appendix 6\\_Section2\\_](#)). The alkaline earth elements present in the water are induced to form a chelate-type complex by EDTA at pH 10. A specific indicator, eriochrome black, detects the disappearance of the last traces of free elements. In a medium adequately buffered to prevent magnesium precipitation, the method determines the sum of calcium and magnesium ions ([Hach, 2015](#)).

### 2.3. Total dissolved solids

The TDS was measured by filtering 500 ml of the water sample and then evaporating in a Bain-Marie. Once all the water has evaporated, heat the pre-weighed capsule in an oven at 180 °C for 4 hours and leave to cool for 1/4 hour in a desiccator until the weight of the capsule no longer changes ([Rodier et al., 2016](#)).

### 2.4. Measure of cations

The Calcium (Ca<sup>2+</sup>), Magnesium (Mg<sup>2+</sup>), Potassium (K<sup>+</sup>), Sodium (Na<sup>+</sup>) contents were determined by flame atomic absorption spectroscopy of type Agilent Technologies 2007 ([Appendix 6\\_Section3\\_](#)) ([Agilent, 2017](#)).

### 2.5. Nitrite

The nitrite determination was measured by a colorimetric method. The diazotization of 4-amino-benzenesulfonamide by nitrites in acidic medium and its coupling with N-(1-naphthyl)-1,2-diaminoethane dichloride ethane gives a purple-colored complex susceptible to spectrometric determination at 543 nm ([Rodier et al., 2016](#)).

### 2.6. Chloride

The chloride (Cl<sup>-</sup>) was measured by the Mohr method based on the argentometric determination ([Appendix 6\\_Section4\\_](#)). Chlorides are determined in a neutral medium by a titrated solution of silver nitrate in the presence of potassium chromate. The end of the reaction

is indicated by the appearance of the characteristic red color of silver chromate (Meija *et al.*, 2016).

## 2.7. Sulfate

The sulfate ( $\text{SO}_4^{2-}$ ) ions are precipitated as barium sulfate and evaluated gravimetrically. Precipitation occurs in a hydrochloric acid medium by the addition of barium chloride. After a period of digestion, the precipitate is filtered, washed with hot water until free of chloride, ignited, and weighed as  $\text{BaSO}_4$  (Rodier *et al.*, 2016).

## 2.8. Dry residue

A dry residue may be used to determine the suspended solids concentration in the water samples; the suspended solids were collected on a glass-fiber filter, and the insoluble residue was dried at  $105^\circ\text{C}$  and weighed (Rodier *et al.*, 2016).

## 3. Metagenomics sequencing

### 3.1. Genomic DNA extraction

The sediment sample and its corresponding replicate were combined and thoroughly mixed until homogenous. Approximately a pea-sized amount of 0.25g was loaded using a disposable spatula into a Power Bead tube. Around 100 ml of the water samples were filtered through a  $0.22\mu\text{m}$  PES filter. After filtering, about  $1/6^{\text{th}}$  of the filter was cut and loaded using disposable tweezers into a Power Bead tube. DNA extraction was performed using the Qiagen DNeasy PowerSoil DNA Isolation kit according to the manufactured instructions (Fig. 2). The extracted DNA was stored at  $-80^\circ\text{C}$ .

### 3.2. Amplicon library preparation

The PCR amplification of the 16S rRNA gene V4 variable region was carried in a two-step process. The first step is to amplify genomic regions of interest, and the second step is to add sequencing adaptors and sample-specific indices to samples. The forward primer was constructed with (5'-3') Illumina i5 sequencing primer (TCGTCGGCAGCGTCAGATGTGTATAAGAGACAG) and the 515F primer ([GTGCCAGCMGCCGCGGTAA]). The reverse primer was constructed with (5'-3') Illumina i7 sequencing primer (GTCTCGTGGGCTCGGAGATGTGTATAAGAGACAG) and the 806R primer ([GGACTACHVGGGTWTCTAAT]).

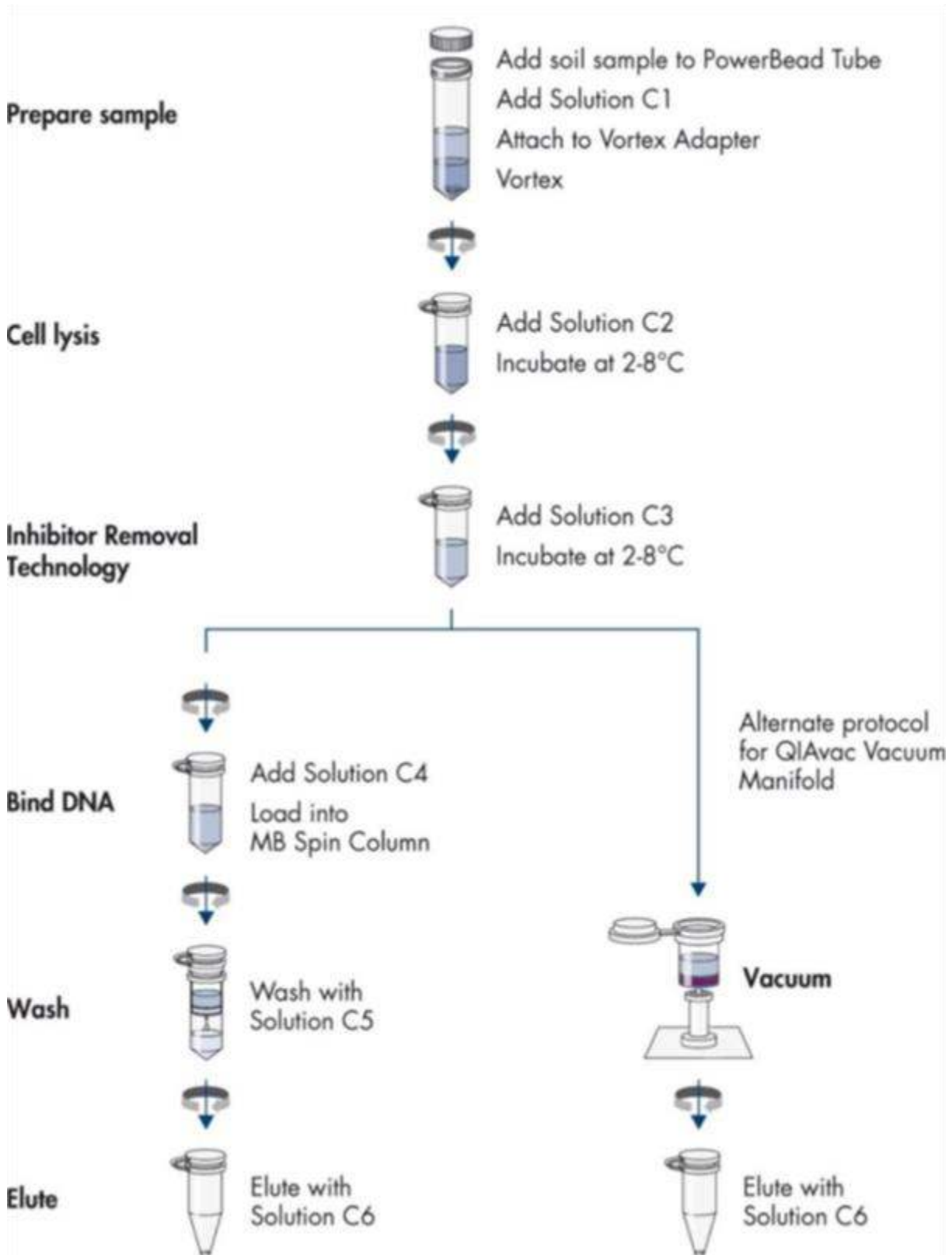

Figure 2. The Qiagen DNeasy PowerSoil DNA isolation procedure (Qiagen, 2017).

The amplifications were performed in 25 µl reactions with Qiagen HotStar Taq master mix (Qiagen Inc, Valencia, California), 1µl of each 5µM primer, and 1µl of the template. Reactions were performed on ABI Veriti thermocycler (Applied Biosystems, Carlsbad, California) under the following thermal profile: 95°C for 5 min, then 35 cycles of 94°C for 30 s, 54°C for 40 s, 72°C for 1 min, followed by one cycle of 72°C for 10 min and 4°C holds.

The products from the first stage amplification were subjected to a second PCR based on qualitatively determined concentrations. Primers for the second PCR were designed based on the Illumina Nextera PCR primers as follows: Forward - AATGATACGGCGACCACCGAGATCTACAC[i5index]TCGTCGGCAGCGTC and Reverse - CAAGCAGAAGACGGCATACGAGAT[i7index]GTCTCGTGGGCTCGG. The second stage amplification was run the same as the first stage except for 10 cycles.

The amplification products were visualized with E-Gels (Life Technologies, Grand Island, New York). The products were then pooled in equimolar ratios. Each pool was size selected in two rounds using SPRI select Reagent (Beckman Coulter, Indianapolis, Indiana) in a 0.75 ratio for both rounds.

The selected pools were then quantified using the Qubit 4 Fluorometer (Life Technologies) and loaded on an Illumina MiSeq (Illumina, Inc. San Diego, California) 2x300 flow cell at 10 pM. Sequencing was performed at RTL Genomics (TX, USA) according to the manufacturer's guidelines.

### 3.3. Bioinformatic data analysis

The sequences obtained from the Illumina sequencing platform were depleted of barcodes and primers using a proprietary pipeline (RTL Genomics TX, USA). The resulting sequences were checked to remove short once <100 base pairs, singleton sequences, and noisy reads by denoising. The forward and reverse reads are taken in FASTQ format and paired lines were merged using the PEAR Illumina paired-end read merger, trimmed using RTL internal trimming algorithm. The FASTQ formatted files were converted into FASTA formatted sequence and quality files (Zhang *et al.*, 2014).

The operational taxonomic units (OTUs) were defined by clustering at 3% divergence (97% similarity), using a USEARCH clustering algorithm. The result of this stage is the consensus sequence from each new cluster, with each tagged to show their total number of member sequences (dereplicated and clustered). The clusters that contain <2 members

(singleton clusters) are not added to the output file, thus removing them from the data set (Edgar, 2010).

The OTUs were selected using the UPARSE OTU selection algorithm to classify a large number of clusters into OTUs (Edgar, 2013). The chimeras on the selected OTUs were inspected using the UCHIME chimera detection software running in *de novo* mode (Edgar *et al.*, 2011).

Each read was mapped to their corresponding nonchimeric cluster using the USEARCH global alignment algorithm. For taxonomic classification, representative OTU sequences were compared to a database of high-quality sequences maintained by RTL Genomics derived from the NCBI database. The output is then analyzed using an internally developed python program that assigns taxonomic information to each sequence and then computes and writes the final analysis files. The resulting raw sequences were submitted to NCBI Sequence Read Archive.

#### 4. Statistical data analysis

To compare the hot springs and sample types, diversity indices (Richness, Shannon, Simpson, Jackknife, Chao1, and ACE) and rarefaction curves were calculated from the resulting OTUs using EstimateS 9.1.0 software (Colwell and Elsensohn, 2014). Venn diagrams comparing the shared OTUs between the hot springs and sample types were performed using R programming language version 3.6.2 (R-Core Team, 2020).

The correlation between physicochemical parameters based on Pearson's correlation coefficient and the principal component analysis (PCA) used to correlate between bacterial diversity at the phylum level and environmental physicochemical parameters of the hot spring's samples were conducted by R programming language version 3.6.2 using 'corrplot' and 'ggplot2' packages (R-Core Team, 2020).

# CHAPTER II

## *Results and discussion*

### 1. Site description and physicochemical characteristics

The sites were chosen based on different conditions of pH and temperature. Debagh Hot spring (H24D) water samples presented slightly acidic (pH=6.27) and hyperthermophilic condition (96°C), while Saïda hot spring (H05S) had moderately alkaline pH (7.45) but lower temperatures than H24D (62.6°C).

The temperature variations between the different sources are probably related to the geology of the region as well as the depth of the hot spring (Hamzah *et al.*, 2013). In the Northeast of Algeria, the thermal waters are of meteoric origin. The geothermal reservoirs are located at 1000–2600 m depth; they are generally of Mesozoic age, mainly of limestone, limestone sandstone, and sandstone type (Kedaid, 2007), which may be one of the factors explaining the high concentration of HCO<sub>3</sub><sup>-</sup> in both sites.

The physicochemical parameters measured are summarized in Table 1. Differences in chemical composition between the two hot springs might, in part, be related to the aquifer rocks' chemical composition, and on the other hand, to differences in water temperature since the solubility of ions change with temperature variations. Although temperature also affects pH; which decreases at higher temperatures, the following was reported in the Debagh hot spring (pH=6.27, T°=96°C) in contrast to Saïda hot spring (pH=7.45, T°=62.6°C).

The ionic balance was calculated for each hot spring water sample as a quality-assurance check and reliability of the chemical analyses. Since water must be electrically neutral, the sum of the milliequivalents of major cations and anions should be nearly equal. The calculated ionic balance error must be within the acceptable limit of ± 5 % using the following equation:

$$\text{Ionic Balance (IB)\%} = \frac{\sum \text{cations} - \sum \text{anions}}{\sum \text{cation} + \sum \text{anions}}$$

For all the water samples, the IB (%) values varied from 0.76 to 2.91% (Tab. 1), and therefore, we consider these chemical analyses reliable. Both thermal springs have a total hardness range of 352–685 mg/l and are regarded as very hard water since TH is more than the acceptable standard of 180 mg/l (WHO, 2017).

The dissolved polyvalent metallic ions, mainly Ca<sup>2+</sup> and Mg<sup>2+</sup> from sedimentary rocks, most frequently limestone, chalk, and soil drainage are the major natural causes of hardness in water (Weiner, 2008).

**Table 1.** Physicochemical characteristics of the water samples collected from Saïda and Debagh springs (North-East, Algeria). (**E.C.:** Electrical Conductivity, **TDS:** Total Dissolved Solids, **Dry residue:** calculated at 105°C, **TH:** Total Hardness in french degree (°F), **TAC:** Total alkalinity (Titre Alcalimétrique Complet) in french degree (°F), **IB:** Ionic Balance (%), **WHO:** World Health Organization).

Parameters	Units	Saïda (H05S)	Debagh (H24D)	WHO guideline (2017)
Temperature	°C	62.6	96	-
pH	-	7.45	6.27	6.5–8.5
E.C.	µs/cm	1380	2010	< 700
TDS	mg/l	883	1486	1000
Salinity	g/l	0.66	1.00	-
Dry residue	mg/l	985	1400	1000
Ca <sup>2+</sup>	mg/l	98.39	220	100-300
Mg <sup>2+</sup>	mg/l	25.53	33	150
Na <sup>+</sup>	mg/l	152	221	200
K <sup>+</sup>	mg/l	15	25	15
Cl <sup>-</sup>	mg/l	60	309	250
SO <sub>4</sub> <sup>2-</sup>	mg/l	414	368	250
HCO <sub>3</sub> <sup>-</sup>	mg/l	225.7	366	400
NO <sub>2</sub> <sup>-</sup>	mg/l	3	3	3
TH	°F	35.2	68.5	50
TAC	°F	18.5	30	50mg/l
I.B.	%	0.76	2.91	-

The electrical conductivity measures the dissolved ionic component in water; it indicates the amount of total dissolved substitution in water. The EC values of thermal mineral waters indicate high mineralization (1380  $\mu\text{S}/\text{cm}$  for H05S and 2010  $\mu\text{S}/\text{cm}$  for H24D), reflecting the high solubility of the salts at high temperatures. According to Rhoades classification, Saïda (H05S) is considered a slightly saline hot spring (700-2,000  $\mu\text{S}/\text{cm}$ ), while Debagh (H24D) is moderately saline (2,000-10,000  $\mu\text{S}/\text{cm}$ ) (Rhoades *et al.*, 1992). Other research suggests similar results for H24D water (Bahri *et al.*, 2011; Amarouche-Yala *et al.*, 2015).

The total dissolved solids (TDS) comprise inorganic salts and small amounts of organic matter dissolved in water. According to the TDS values obtained, the H05S water had fair palatability (TDS between 600 and 900 mg/l), while water samples from H24D are unacceptable for drinking since the TDS concentration was more than 1200 mg/l (WHO, 2017). Similar results were reported by Fekraoui and Kedaid (2005), with a TDS value of 1,600 mg/l for the Debagh thermal spring. Concentrations of TDS in hot spring water vary considerably according to different geological regions and differences in mineral solubilization. The relatively high EC and TDS may be explained by the concentration and the type of dissolved ions, the hydrothermal alteration of sedimentary rocks, and the high temperature, which enhances the dissolution of ions (Bahri *et al.*, 2011).

In addition to electrical conductivity and total dissolved solids, salinity is usually defined as dissolved salt per unit volume of water, expressed in units of g/l or ‰. Water samples from both hot springs presented high salinity; 0.66‰ for H05S and 1.00‰ for H24D; these waters cannot be considered freshwater as the salinity exceeded 0.05 ‰. They can be classified as saline geothermal water and, therefore, brackish water (Velmurugan *et al.*, 2020).

For the cations in H05S water, Na, Ca, Mg, and K concentrations were 152, 98, 25, and 15mg/l, respectively. The abundance of major ions in thermal water was in the order of Na > Ca > Mg > K for cations, and they contribute on an average of 52.24, 33.81, 8.77, and 5.16 ‰, respectively, to the total cation content. More than half of the samples are categorized as sodium waters as Na was the dominant cation. None of the specimens showed a Na, Ca, Mg, and K concentration above their respective permissible limit of 200, 300, 150, and 15 mg/l (WHO, 2017). Sulfate was dominant among all the anions, suggesting that the H05S water samples were sulfate-rich water. None of the models showed  $\text{Cl}^-$  and  $\text{HCO}_3^-$  concentrations above their respective permissible limits of 250 and 400 mg/l. Only sulfate concentration was higher than the tolerable threshold of 250 mg/l (WHO, 2017). The order of abundance of major anions was  $\text{SO}_4 > \text{HCO}_3 > \text{Cl}$ .

The Debagh (H24D) water presented no dominant cations or anions (Tab. 1); similar results were reported by [Amarouche-Yala et al. \(2015\)](#).

A Pearson correlation matrix was established to determine the relationships between the different variables to assess the various associations between the main hydrochemical variables (Fig. 3).

The Pearson correlation coefficients show strong correlations between Cl, Ca, K, Na, and TDS (0.98, 0.96, 0.94, and 0.92), respectively, indicating that the mineralization is mainly influenced by Cl, Ca, K, and Na ([Quattrini et al., 2016](#)). There is a high correlation between electrical conductivity and total dissolved solids (TDS) with  $R^2 = 0.98$  and salinity with  $R^2 = 0.99$ . The correlation between TDS and salinity was  $R^2 = 0.94$ . Strong correlations are obtained between these three parameters; TDS describes the inorganic salts and small quantities of organic matter present in the water.

The calcium, magnesium, sodium, and potassium cations, besides hydrogencarbonate and chloride, are typically the primary constituents, where a strong correlation was noted. As salinity measures the amount of salts in the water, and conductivity is the capacity of water to conduct an electrical current, the presence of these dissolved salts directly increases the value of salinity and conductivity ([Corwin and Yemoto, 2017](#)).

The total hardness was strongly correlated to total alkalinity and hydrogencarbonate concentration in thermal water, with  $R^2 = 0.95$  for both. Hardness is often defined as the sum of polyvalent cations ( $\text{Ca}^{2+}$  and  $\text{Mg}^{2+}$ ) concentrations dissolved in the water. The key feature of water alkalinity and hardness is:

- (i) The geology of the region where the surface or groundwater is located, and
- (ii) The atmospheric dissolution of  $\text{CO}_2$ . The ions responsible for alkalinity and hardness derive from the dissolution of geological minerals in rain and groundwater.

Naturally, rainwater is acidic, which seems to solubilize several minerals more effectively. Due to the dissolution of bicarbonates and carbonates, surface and groundwater reservoirs in the region with limestone formations are particularly likely to have high hardness and alkalinity ([Wilson, 2013](#)).

The total alkalinity is a measure of water's acid-neutralizing potential. It is a combined measure of the sum of all the titratable bases in water, mainly carbonate ( $\text{CO}_3^-$ ), bicarbonate ( $\text{HCO}_3^-$ ), and hydroxyl ( $\text{OH}^-$ ) anion ([Weiner, 2008](#)), which may explain the very high correlation between TAC and  $\text{HCO}_3^-$  ( $R^2 = 0.95$ ).

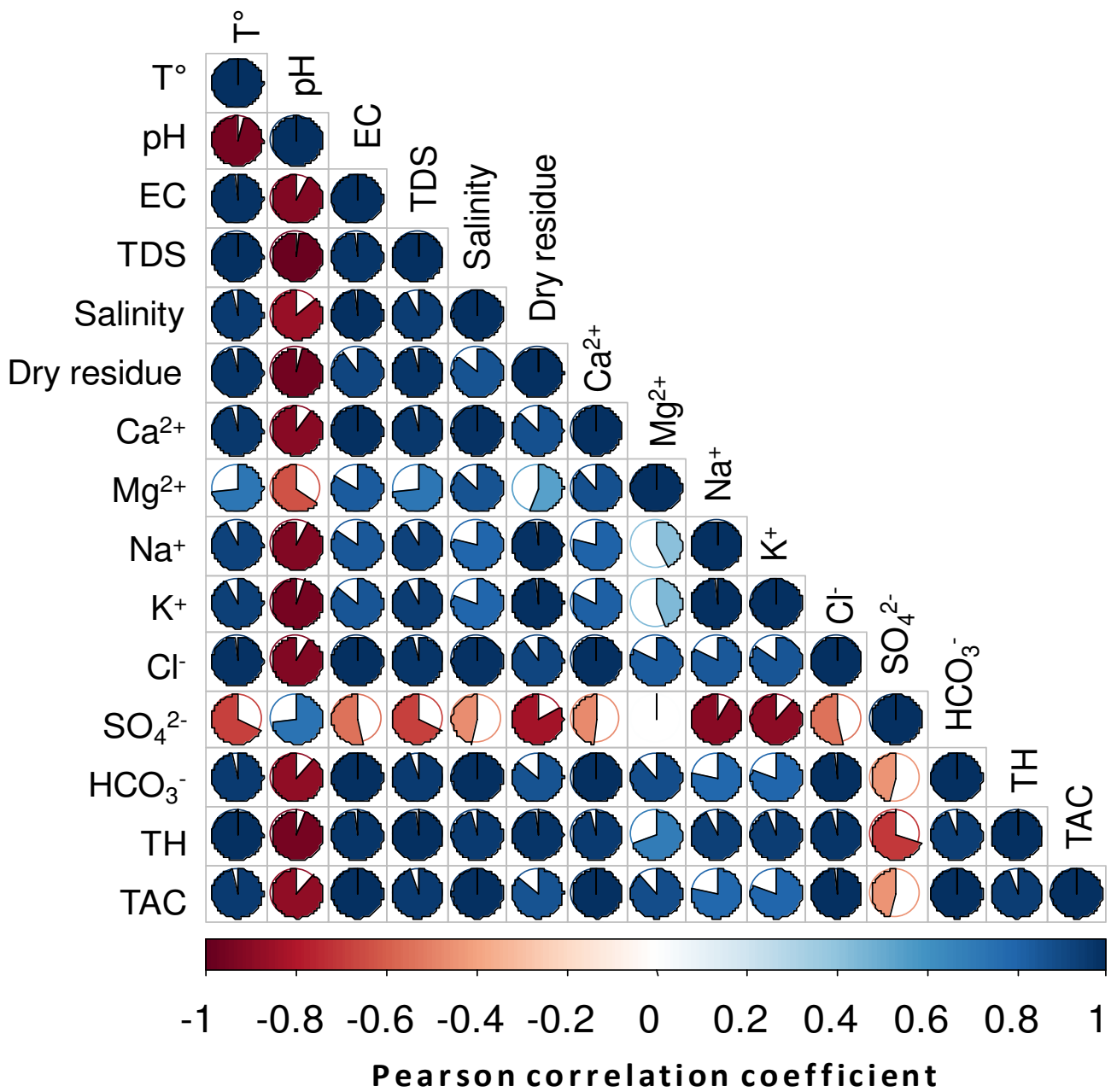

**Figure 3.** Correlogram based on Pearson correlation determining interactions between the main hydrochemical parameters.

## 2. Thermal water classification

Each ion concentration was plotted on the Piper diagram and Schöeller-Berkaloff diagram (Fig. 4, and Fig. 5) to classify the hot springs water based on chemical composition. The two symbols in Fig.4, a blue circle and a red circle, indicate the spring position. Both diagrams were performed using 'DIAGRAMMES,' the Water Software Quality Hydrochemistry Diagrams of the Avignon Hydrogeology Laboratory (France) version 6.5.

The Piper diagram shows that the two hot springs belong to different types of spring water; H05S belongs to the sodium-sulfate type while H24D has calcium-sulfate chloride (Ca-Cl-SO<sub>4</sub>) chemical facies. The Debagh hot spring (H24D) water is characterized by the predominance of the calcium and chloride ions, confirming the water interaction with carbonate minerals and their dissolution and depositional processes since the country's Northeastern region consists mainly of carbonate reservoir rocks formations. The primary source of chloride in the waters is sedimentary rock (Saibi, 2009). The Schöeller diagram (Fig. 5) is also used in this research to determine the water quality type and assist in distinguishing similar patterns in the anion and cation ratios. The results obtained from the Piper diagram seem to be compatible with the results acquired from the Schöeller-Berkaloff.

The variation of the hydrochemical facies of Saïda hot spring (H05S), with predominant elements of sodium and sulfates and impoverishment in magnesium and bicarbonates, is related to the reservoir water-rock interaction consisting essentially of sands, sandstones, gypsum, and a small clay fraction. The origin of sulfate is the dissolution of gypsum (CaSO<sub>4</sub>·2H<sub>2</sub>O), anhydrite (CaSO<sub>4</sub>), and sulfide oxidation. The high sodium content is mainly related to the rapid dissolution of the evaporite formations (Halite) near the up-flow area of this hot spring noted in the Eastern part of the studied area.

The geochemical facies of H24D in the Piper diagram support the dominance of alkaline earth metal over alkali metal from the hot spring groundwater (Ca + Mg > Na + K), and strong acids anions exceed weak acids anions (i.e., Cl+SO<sub>4</sub> > HCO<sub>3</sub>), while in H05S hot spring water, alkalis exceed alkaline earth.

## 3. Drinkability of thermal water

Since ancient times, hot springs water was explored for its balneotherapeutic potential, ensuring therapeutic effects on various diseases (Narsing Rao *et al.*, 2018), which motivated people to drink the thermal water seeking healing. Therefore, during this study, we checked the drinkability of the thermal water from the two hot springs by investigating the physicochemical parameters according to the World Health Organization standards.

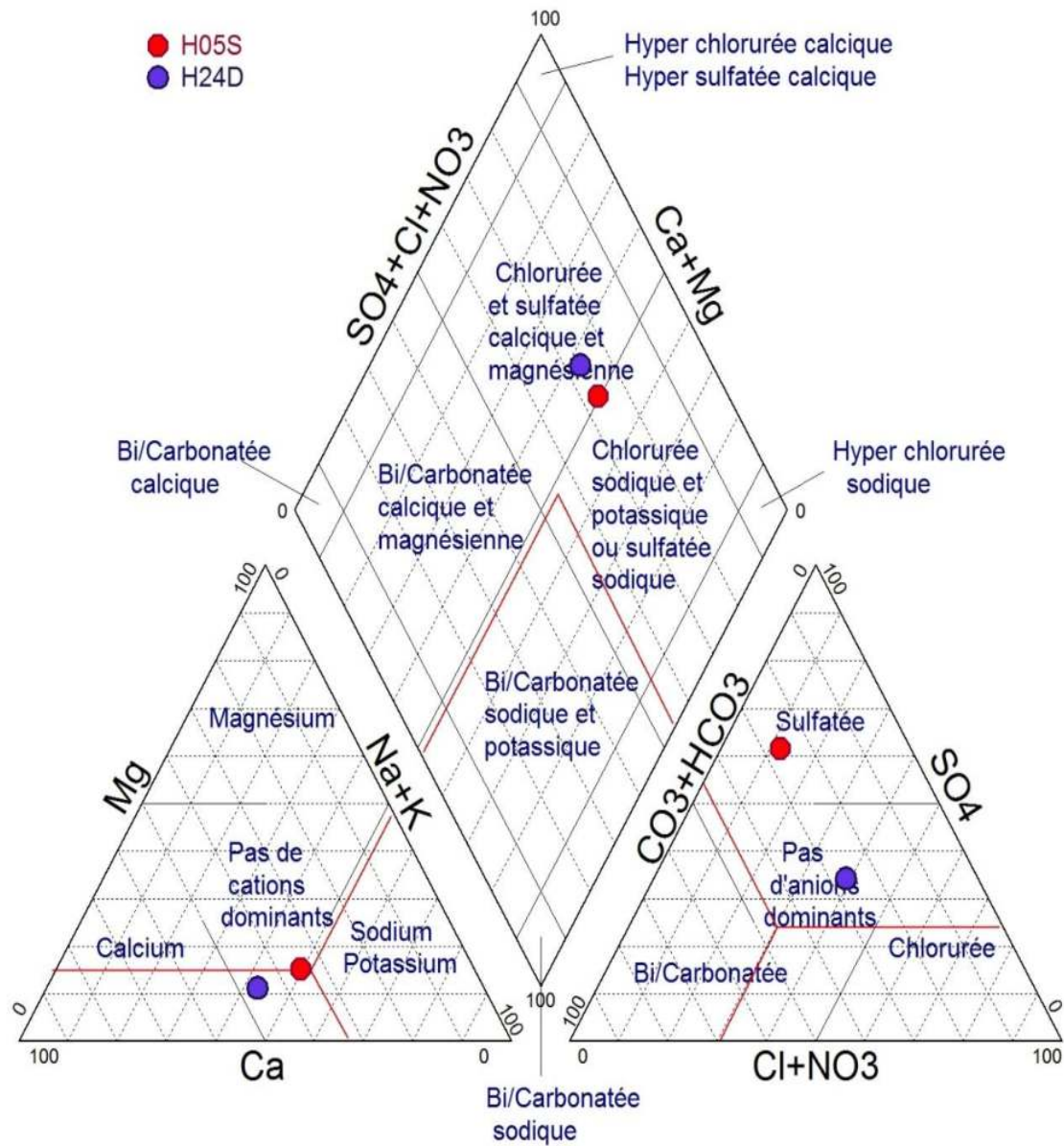

**Figure 4.** The Piper trilinear diagram representing the chemical facies of the two thermal springs water.

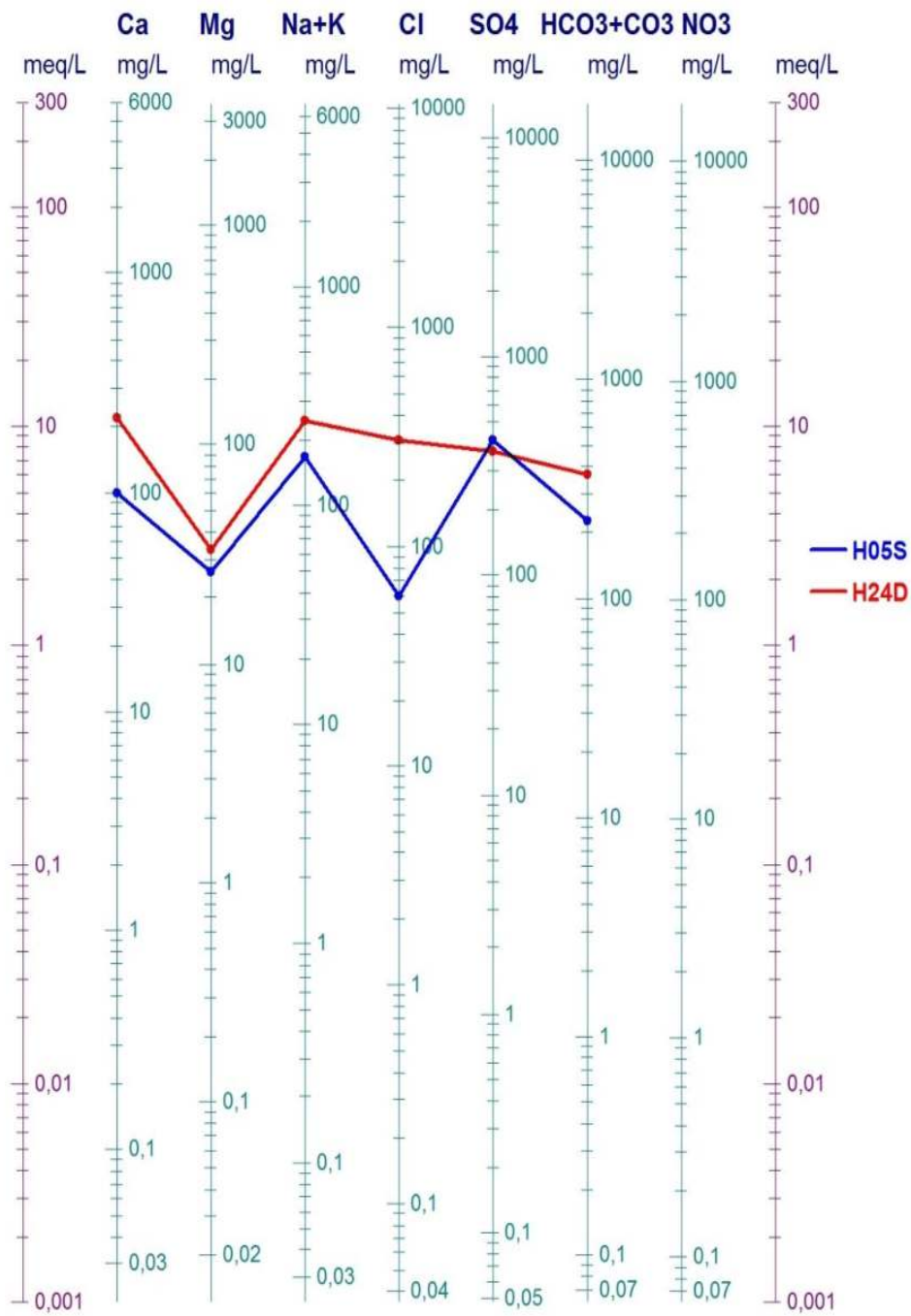

Figure 5. The Schöeller-berkaloff diagram displaying the two thermal springs water.

For Saïda spring (H05S) water, several physicochemical values of all the samples were within the limit regarding WHO guidelines (WHO, 2017) except for one parameter (Tab. 1). The H05S was the least mineralized spring. The concentrations show low values except for sulfate (414 mg/l), which displayed a high value surpassing by far those of WHO (250 mg/l), consequently H05S spring water is safe to be drinkable without any special precautions. For a long time, this thermal water has supplied the company 'N'gaous-conserve' in N'gaous province of Batna, specialized in fruit processing, manufacturing, and marketing of fruit waters, juices, and canning. Sulfates occur naturally in water, but no health-based guideline is proposed, however, because of the gastrointestinal effects in unaccustomed consumers resulting from the ingestion of drinking water containing high sulfate levels; some researches indicate a laxative effect at concentrations of 1000–1200 mg/l (Heizer *et al.*, 1997). Sulfate is based on taste threshold, not on health consideration; it is recommended by international regulations that sulfate concentrations, not excess 250 mg/l, to avoid the noticeable salty and bitter taste. Mainly, the taste impairment varies with the nature of the associated cation (López *et al.*, 2017).

Regarding the Debagh hot spring (H24D), the findings indicate that the concentrations of major ions are higher than the norms (Tab. 1). The spring presented hard waters basing on EC, TDS, TH, and TAC results with a mineral content ( $\text{Ca}^{2+}$ ,  $\text{Na}^+$ ,  $\text{K}^+$ ,  $\text{Cl}^-$ ,  $\text{SO}_4^{2-}$ ,  $\text{HCO}_3^-$ , and  $\text{NO}_2^-$ ) exceeding WHO standards (WHO, 2017). As a result, this water is contraindicated for consumption, which should be mentioned for spa users in this region. Other researchers reported similar results reporting that Debagh water is not suitable for consumption since the water was hard with high mineral content exceeding WHO standards (Bahri *et al.*, 2011).

#### 4. Metagenomic sequencing analysis

We chose to carry out a culture-independent strategy of 'metagenomics' by high-throughput sequencing amplicons of the V4 hypervariable region of the 16S rRNA gene.

The 16S rRNA gene of bacteria comprises interspersed conserved and variable sequences, including nine hypervariable regions (V1–V9). The primers used in this study amplified the variable region (V4). The part of the 16S rRNA gene-targeted during sequencing is crucial for accurate taxonomic assignment (Liu *et al.*, 2008).

Similar hypervariable regions have been revealed to have different efficacies in terms of bacterium detection. Based on the geodesic distance between different sub-regions, V4 and V6 were the most reliable regions representing full-length 16S rRNA sequences in phylogenetic analysis of most bacterial phyla. At the same time, V2 and V8 were the least reliable regions (Yang *et al.*, 2016).

To evaluate the microbial communities' composition in the two sites' water and sediment, the obtained reads were analyzed by blastn against the NCBI NT nucleotide database.

A total of 120,743 raw sequences were obtained and processed following the proprietary pipeline (RTL Genomics TX, USA), resulting in 103,538 clean sequences after filtering for quality and removing chimeras. Sediment samples from H05S had the most important reads (39,282), followed by water samples from the same site (24,082). About (21,262) good reads were related to water samples from H24D, and (18,912) reads from H24D sediments. The average length coverage was 292 bp. All the sequences were clustered into 2812 OTUs at the 97% sequence similarity value (Appendix 6).

The analysis revealed that *Bacteria* dominated both sites. At the kingdom level, Debagh hot spring (H24D) presented the highest proportion of *Bacteria* in water (99.85%) and sediment (91.16%), while *Archaea* represented 0.14% and 0.66%, respectively. On the other hand, Saïda hot spring (H05S) water's microbial community was composed of only *Bacteria* while the sediment was represented by 0.86% *Archaea* and 90.93% *Bacteria* (Fig. 6). These results suggest that bacteria are the most dominant taxa in the two hot springs. Similar results were reported in Malaysian, Eritrean, and Algerian hot springs, respectively (Chan *et al.*, 2015; Ghilamical *et al.*, 2017; Adjeroud *et al.*, 2020).

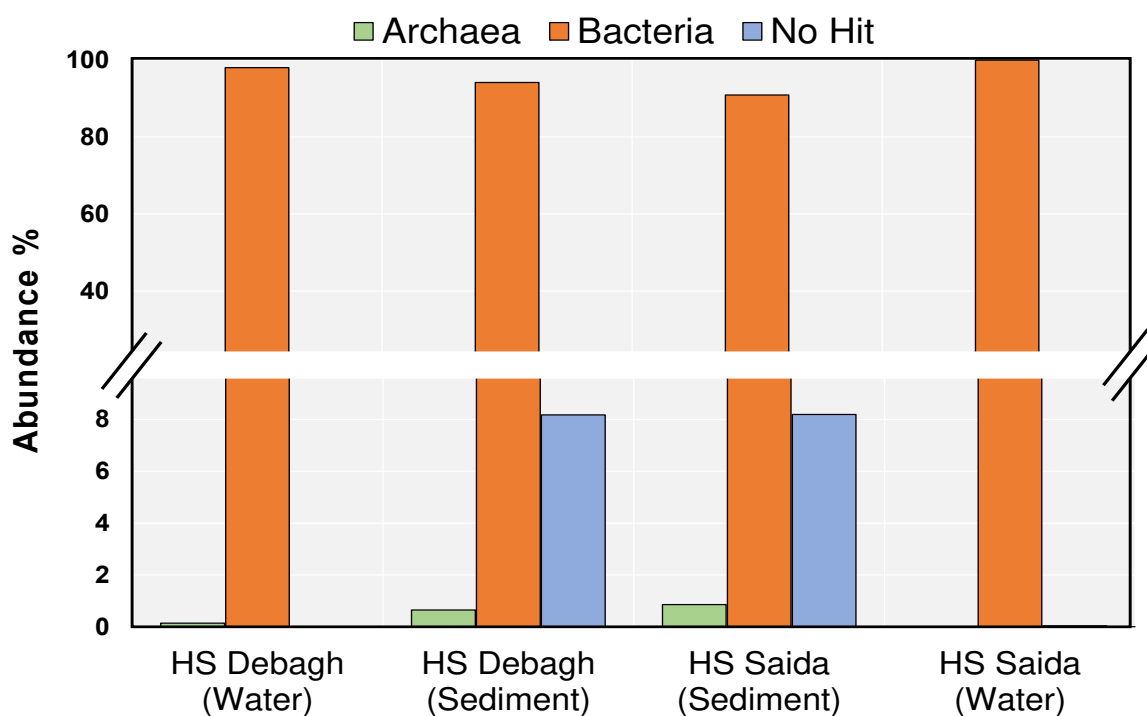

**Figure 6.** Relative abundance of the microbial kingdom in analyzed water and sediment from the two hot springs.

The detected archaeal sequences (0.51%) were affiliated with the obligately thermophilic *Crenarchaeota* (70.30%), *Thaumarchaeota* (28.48%), and *Euryarchaeota* (1.21%). The dominant archaeal phylum *Crenarchaeota* included mainly *Thermoproteales* (50.90%), in addition to some minor order like *Desulfurococcales* (09.09%). The archaeal sequences that remained unclassified at the phylum level were 66.73%, distributed as follows 24.05% in H24D and 86.68% in H05S hot spring.

The archaeal reads classified at the genus level fell into six different genera at H24D and four at H05S hot spring. Most *Euryarchaeotal* sequences fell into the class *Methanobacteria* and were mainly related to the genera *Methanothermobacter*. The *Crenarchaeota*, members of the hyperthermophilic class *Thermoprotei* affiliated to the genera *Desulfurococcus*, and *Pyrobaculum* were retrieved only from the high-temperature condition in H24D. Sequences of *Thaumarchaeota* retrieved in both hot springs remain unclassified.

*Archaea* are a minor part of the prokaryotic community at the Algerian hot springs, similarly to many other terrestrial hot springs and shallow hydrothermal systems worldwide (Gugliandolo *et al.*, 2015). Around 88.79 % of the *Crenarchaeota* belonged to Debagh hot spring where the temperature was high (96°C). This phylum was represented by *Desulfurococcus* and *Pyrobaculum*, which is consistent with the known hyperthermophile of these organisms. *Desulfurococcus*; an anaerobic sulfur-reducing hyperthermophilic bacteria (temperature optimum 90–95°C) and *Pyrobaculum*; a hyperthermophilic, with optimum growth temperature: 100°C (Huber and Stetter, 2015; Zillig, 2015).

The minority frequency of *Euryarchaeota* (1.21%) reported in this high-temperature hot spring was represented by *Methanothermobacter*, a thermophilic Gram-negative, a strictly anaerobic methanogenic bacterium (Boone, 2015). At low temperature, in H05S hot spring, most hyperthermophilic members decreased; however, the abundance of more specific mesophilic *Archaea* increased. They were represented mainly by *Thaumarchaeota*. This phylum is known as mesophilic *Crenarchaeota*, an extremely diverse group most often grouping uncultured members (Reysenbach, 2015). The *Archaea* have adapted to survive in extreme environments and may be responsible for various ecosystem functions.

Studies on the bacterial diversity of hot Algerian environments by non-cultural methods are scarce (Gomri *et al.*, 2018; Adjeroud *et al.*, 2020). This study is the first attempt to assess the archean diversity of Algerian hot springs. However, the development and the biological diversity of *Archaea* in hydrothermal sites are poorly understood and need further studies.

The bacterial fragments were classified into 117 classes, 269 families, and 943 genera. All the obtained bacterial sequences fell into 49 prokaryotic phyla, of which 14 bacterial phyla showed relative ratios  $\geq 1\%$ : *Acidobacteria*, *Armatimonadetes*, *Bacteroidetes*, *Chlorobi*, *Chloroflexi*, *Cyanobacteria*, *Deinococcus-Thermus*, *Fibrobacteres*, *Firmicutes*, *Nitrospirae*, *Proteobacteria*, *Spirochaetes*, *Verrucomicrobia*, and JQ086867\_p (Fig. 7).

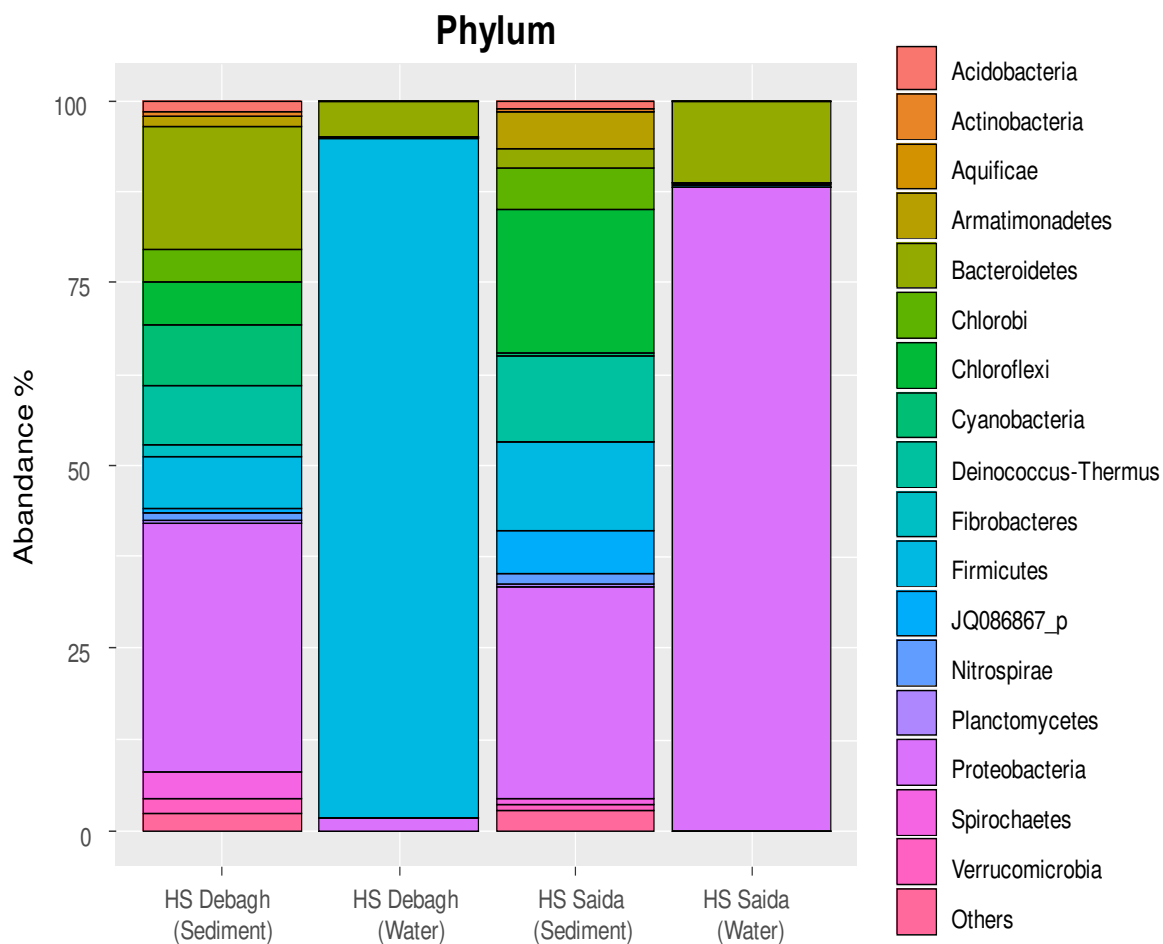

**Figure 7.** Relative abundance of the bacterial phyla in four samples from the two hot springs (Debagh and Saïda).

These major groups varied in relative abundance among the two hot springs. The various samples revealed a succession of different phyla, ranging from hyperthermophiles to moderate thermophiles and mesophiles. Water samples have the lowest phyla counts than sediment samples, with seven in H05S and 15 in H24D. A total of 46 phyla were retrieved from H05S sediments and 36 from H24D, of which 33 were common to both conditions.

The *Proteobacteria* was the most represented taxa at the phylum level in almost all samples, except the H24D water samples where *Firmicutes* was the dominant phylum (93%). Similar results were reported from the metagenomic investigation of bacterial and archaeal

diversity of Hammam Essalihine hot spring from Khenchela City in Algeria (Adjeroud *et al.*, 2020). *Proteobacteria* has also been reported from many studies of hot springs at various geographical locations (Ghilamicael *et al.*, 2017).

Overall, in H24D hot spring sediment, phylum *Proteobacteria* had a relative abundance of 29.11%, *Chloroflexi* of 19.85 %, *Firmicutes* of 12.12%, and *Deinococcus-Thermus* 11.60%. In comparison, H05S sediment samples showed the high relative abundance of *Proteobacteria* (33.97%), followed by *Bacteroidetes* (16.97%), *Cyanobacteria* (8.43%), and *Deinococcus-Thermus* (7.85%). The hot spring of Saïda water samples was dominated by *Proteobacteria* (88.16%) and *Bacteroidetes* (11.15%). In contrast, the hyperthermophilic hot spring (H24D) showed the dominance of *Firmicutes* (93.01%), followed by *Bacteroidetes* (5.04%) and *Proteobacteria* (1.89%) from water samples.

The eighteen candidate divisions representing 7.83% of total sequences were retrieved from all the hot springs. The candidate division JQ086867\_p was the most dominant. Of the 16S rRNA filtered reads recovered from the sediment samples, 9.75% could not be classified into any phylum under the *Bacteria* domain. In contrast, only 0.025% of the water samples could not be classified.

Many geothermal ecosystems with moderately high and very high temperatures have previously been described as dominated by the phylum *Proteobacteria* (Lau *et al.*, 2009). However, hot springs in Yellowstone National Park (U.S.A.) and Tengchong (China) are not associated with this finding (De León *et al.*, 2013; Hou *et al.*, 2013). In our study, *Proteobacteria* was detected as the dominant bacteria. This phylum was represented by seven classes; *Gammaproteobacteria* (62.17%), *Betaproteobacteria* (18.05%), *Alphaproteobacteria* (7.60%), *Deltaproteobacteria* (7.50%), *Hydrogenophilalia* (2.79%), *Epsilonproteobacteria* (1.74%), and *Oligoflexia* (0.15%).

In the high-temperature hot spring (H24D), the main dominant genera of *Gammaproteobacteria* were the obligate methanotroph *Methylothermus*, while *Pseudomonas*, *Acinetobacter*, *Alishewanella*, and *Cavicella* were mostly reported in H05S hot spring.

In previous studies, some mesophilic bacterial species have been detected in high-temperature hot springs (Sharma *et al.*, 2020). The genus *Acinetobacter* and *Alishewanella* reported having an optimum growth temperature between 35-37°C and 37°C respectively were also recovered predominantly from extremely high-temperature Tattapani hot spring (98°C) from central India for *Acinetobacter* (Saxena *et al.*, 2017) and Soldhar hot spring in India for *Alishewanella* (Sharma *et al.*, 2017). This may indicate the tolerance of some mesophilic

bacteria to high temperatures. Biofilms allow bacterial consortiums to tolerate extreme temperatures in conjunction with other environmental factors from the natural environment (Ghilamicael *et al.*, 2017).

Surprisingly, 1OUT affiliated with *Thermomonas*, a member of the  $\gamma$ -proteobacteria, were recovered from the sediment sample of Debagh hot spring (H24D). Strains affiliated to the genus *Thermomonas* have been described previously as ferrous iron-oxidizing and nitrate-reducing bacteria. *Thermomonas* has been described as moderately thermophilic bacteria with an optimum between 37 and 50 °C (Denner *et al.*, 2015).

The sulfate-reducing bacteria (SRB) of the class *Deltaproteobacteria* are major constituents in the low-temperature hot spring (H05S); they were represented mainly by *Desulfuromonadales*, *Desulfovibrionales*, and *Desulfobacterales*. The temperature and oxygen content of the sites may have influenced the distributions of these SRB since the samples from H24D were collected from surface water and therefore had a low temperature and higher oxygen content.

In the Philippines' high-temperature spring BAL-0 (90.8°C), sequences associated with *Sulfobacillus* predominated (Huang *et al.*, 2013). *Nitrosomonas*, from  $\beta$ -proteobacteria, were recovered from the water sample of Egedi hot spring (100°C) located in the Alid volcanic center; Eretria (Ghilamicael *et al.*, 2017). Considering the temperature range for growth of the genus *Sulfobacillus* is between 20 and 60°C (Vos *et al.*, 2009). Its predominance in the Philippines' high-temperature springs BAL-0 (90.8 °C) and MAL-1 (75.8 °C) was unexpected, suggesting that *Sulfobacillus* could have higher temperature tolerance than currently known (Huang *et al.*, 2013).

The anoxygenic phototrophic *Chloroflexi* was represented mainly by *Anaerolineae* (84.85%), *Chloroflexia* (8.71%), *Caldilineae* (3.32%), and other minor classes; *Dehalococcoidia*, *Thermomicrobia*, *EU181507\_c*, *GQ396871\_c*, *HM748667\_c*, and *PDJQ\_c*, *SAR202\_c* representing frequencies between (1.85% and 0.03%). Similar results were reported from a Pakistani Hot spring (Amin *et al.*, 2017). In both temperature environments, sequences associated with photosynthetic members of the *Chlorobi*, *Chloroflexi*, and *Cyanobacteria* were detected. However, *Chloroflexi* sequences were more abundant at high temperatures, while *Cyanobacteria* and *Chlorobi* were more prevalent at low temperatures as previously reported at a shallow marine thermal brine pool in Panarea Island, Italy (Gugliandolo *et al.*, 2015).

The *Chlorobi*, also known as green sulfur bacteria, is the sister taxon of the *Bacteroidetes* phylum (Garrity and Holt, 2015). This phylum was represented by a single order

*Ignavibacteriales* in the class *Ignavibacteria* regrouping two families, *Ignavibacteriaceae* and *Melioribacteraceae*, containing a single species *I. album* and *M. roseus*, respectively. *Ignavibacterium album* was described as an organotrophic, strictly anaerobic, and moderately thermophilic rod-shaped Gram-negative bacterium. It was assumed to be the first non-photosynthetic, non-autotrophic, and chemoheterotrophic member of *Chlorobi* (Iino *et al.*, 2010).

*Melioribacter roseus* is a facultatively anaerobic moderately thermophilic obligate chemoorganotrophic and cellulolytic bacterium. Based on their 23S rRNA and RecA sequences, phylogenetic analysis of *M. roseus* and *I. album* confirmed that these two species could represent a deeper phylum-level lineage (Podosokorskaya *et al.*, 2013). Therefore, Podosokorskaya *et al.* (2013) propose a new phylum, *Ignavibacteriae*, arguing that *Ignavibacteria* deserves to be placed in an even deeper, phylum-level lineage with *Chlorobi* and *Bacteroidetes* as their closest relatives.

Eight genera represented the *Cyanobacteria*, among them five were thermophilic cyanobacterium *Synechococcus*, *Leptolyngbya*, *Oscillatoria*, *Chlorogloeopsis*, and *Fischerella* occurring in hot springs worldwide at temperatures up to 62°C-64°C. Around 80.30% of these genera were reported in low temperatures H05S hot spring (*Tychonema*, *Chroococciopsis*, and *Prochlorococcus*); similar results were reported when investigating the cyanobacterial diversity of Algerian hot springs (Amarouche-Yala *et al.*, 2014).

Same for *Chlorobi*, which was represented by moderately thermophilic *Ignavibacterium* and *Melioribacter* (Iino *et al.*, 2010; Podosokorskaya *et al.*, 2013). *Chloroflexi* was represented mainly by two thermophilic, neutrophilic, and strictly anaerobic chemoorganoheterotroph genera; *Anaerolinea* and *Bellilinea* belonging to *Anaerolineae* (84.85%) (Yamada and Sekiguchi, 2018a, 2018b).

The *Alphaproteobacteria* also included photosynthetic species. The *Rhodospirillaceae*, a family dominated by photosynthetic purple non-sulfur bacteria represented by *Rhodobacter* (Imhoff, 2015), was isolated mainly from low temperatures H05S hot spring.

The *Synechococcus* species have been used to synthesize biofuel and various bioactive compounds of biotechnological applications interest (Pembroke *et al.*, 2020). While, *Leptolyngbya* species have been studied for their potential use in bioremediation of hydrocarbon-contaminated environments (Al-Bader *et al.*, 2012).

All members of the phylum *Cyanobacteria* and *Chloroflexi* were once thought to be obligate photoautotrophs. However, recent phylogenomic research revealed non-phototrophic

lineages recovered from various sources such as gut and groundwater (Bennett *et al.*, 2020). According to the results of this research, several non-photosynthetic genera have been isolated from the studied hot springs mostly: *Anaerolinea*, and *Bellilinea* (*Chloroflexi*), *Ignavibacterium*, and *Melioribacter* (*Chlorobi*).

Another dominant phylum, the *Firmicutes*, is mainly represented by 84.96% of *Bacilli*, 14.58% of *Clostridia*, besides other minor classes such as *Erysipelotrichi*, *Limnochordia*, *Negativicutes*, *Thermolithobacteria*, and *Tissierellia*. The *Firmicutes* are supposed to have an ecological adaptive advantage under low-nutrient conditions of the hot springs, which explains their high relative abundance (Kambura *et al.*, 2016). The *Bacillales* order represented the majority of *Clostridia*. Taxa placed in this order generally included chemolithoautotrophic, Gram-positive endospore-forming bacteria with glycolytic, saccharolytic, and pectolytic activities.

The phylum *Deinococcus-Thermus* in Algerian hot springs was dominated by *Meiothermus* (94.53%) with some *Thermus* (4.66%) and *Deinococcus* (0.71%) belonging all to the sole class *Deinococci*; extremely resistant to environmental challenges. The genera *Thermus* and *Meiothermus* have been found in a wide range of hot springs around the world, with temperatures ranging from 50 to 99°C (Costa *et al.*, 2018), however, except for a few springs in Iceland and the Tibetan plateau, *Thermus* and *Meiothermus* are rarely dominant in terrestrial hot springs (Tobler and Benning, 2011; Wang *et al.*, 2013).

The *Meiothermus* spp. are slightly thermophilic, with optimum growth temperatures of 45–60°C; with a maximal temperature < 70°C. Growth is chemoorganotrophic, aerobic with a strictly respiratory type of metabolism (Albuquerque *et al.*, 2018b). *Thermus* are thermophilic bacteria, with an optimum growth temperature of about 65–75°C; most strains have a maximum growth temperature below 80°C, but some grow at slightly higher temperatures (Nobre *et al.*, 2018).

All *Deinococcus* (100%) were isolated from low-temperature Saïda hot spring, which is compatible with its physiology. Species are mesophilic or thermophilic, with optimum growth temperatures of 25–35°C or 45–50 °C, respectively. All-natural isolates are ionizing-radiation resistant (Battista and Rainey, 2015). The predominance of *Meiothermus* over *Thermus* in the high-temperature hot spring is surprising because most species of *Thermus* are thermophilic, whereas *Meiothermus* spp. are slightly thermophilic. Likewise, the same result was reported in Eretrian hot springs (Ghilamical *et al.*, 2017).

From all samples, the five classes with the most assigned reads were *Gammaproteobacteria* (24.31%), *Bacilli* (20.42%), *Betaproteobacteria* (7.06%), *Bacteroidia* (5.43), and *Deinococci* (5.15%) (Fig. 8).

At the level of the sediment samples of H24D, we found a relative abundance of 17.59% for *Anaerolineae*, *Gammaproteobacteria* (11.94%), *Deinococci* (11.60%), *Betaproteobacteria* (9.29%), and *Bacilli* (6.33%). In comparison, H05S sediment samples had a relative abundance of 13.77% for *Bacteroidia*, 12.93% of *Gammaproteobacteria*, 8.86% of *Betaproteobacteria*, and 7.84% of *Deinococci*. From the water samples, *Bacilli* showed the highest mean relative abundance in H24D hot spring (93.01%) compared to the slight fraction of (0.26%) in Saïda spring dominated by 74% of *Gammaproteobacteria*.

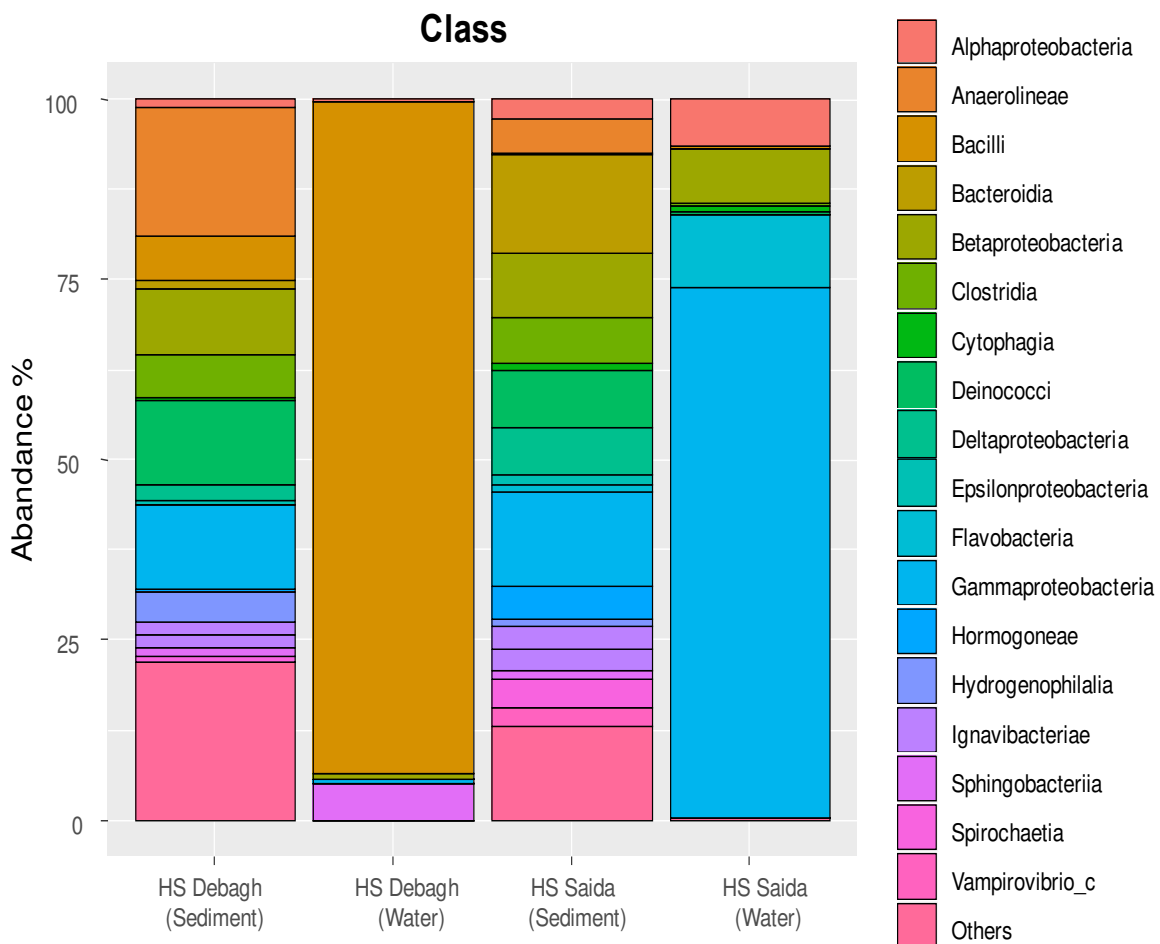

**Figure 8.** Relative abundance of the bacterial classes in four samples from the two hot springs (Debagh and Saïda).

The OUT's comprised a total of 269 families. Among the most abundant in water samples were *Paenibacillaceae* (38.25%), *Pseudomonadaceae* (15%), *Moraxellaceae*

(14.25%), and *Alishewanella\_f* (09.61%). However, in sediment samples from hot springs, the abundant existence was represented by *Thermaceae* (09.05%), *Anaerolinaceae* (7.72%), *Methylothermaceae* (05.09%), and *Porphyromonadaceae* (03.58%) (Fig. 9).

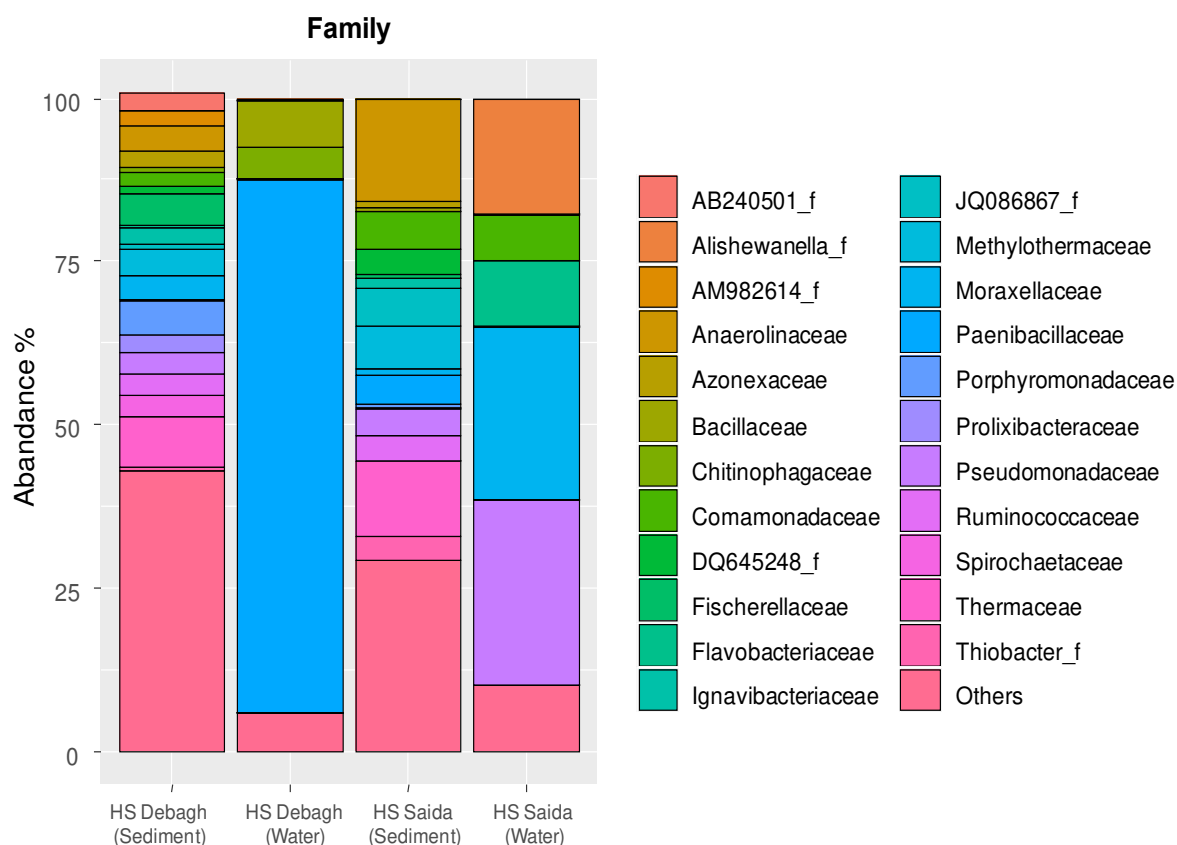

**Figure 9.** Relative abundance of the bacterial families in four samples from the two hot springs (Debagh and Saïda).

The reads classified at the genus level fell into 943 different genera in all sites (Fig. 10,11). Detailed analysis of the bacterial community composition at the genus level showed that *Brevibacillus* (15.02%) and *Pseudomonas* (8.51%) were the most abundant genera. *Meiothermus* (8.64%), *Methylothermus* (5.08%), and *Anaerolinea* (5.01%) were a large group of microorganisms in both sediment samples. None of these genera were detected in the water samples where the most common genus was *Brevibacillus* (33.93%).

The presence of *Pseudomonas* was not surprising given the findings of Selvarajan et al. (2018), who also detected the dominance of this genus. *Pseudomonas* spp. is well-known to form biofilms due to their metabolic versatility in extreme environments. *Pseudomonas* was also reported in Anthoni hot springs (India) and was associated with genes linked to hydrocarbon degradation pathways (Saxena et al., 2017). Infrequent psychrophile-related sequences such as

*Sporosarcina* were also detected. The low-temperature adapted bacteria's survival strategy in hyperthermophilic environments is poorly understood and needs further studies (Bendia *et al.*, 2018).

The contamination of the hot spring water by surface water, soil, and spores cannot be excluded. Still, it can be assumed that the bacterial phylotypes detected can probably all proliferate in this thermophilic ecosystem.

In this work, most *Aquificae* genera belonged to *Hydrogenobacter*, in addition to other minority genera such as *Hydrogenivirga* or *Aquificales* genera *incertae sedis* (Latin: uncertain placement). Similarly, in high-temperature Tengchong springs (China), *Hydrogenobacter* was the dominant genus from *Aquificae* (Hou *et al.*, 2013).

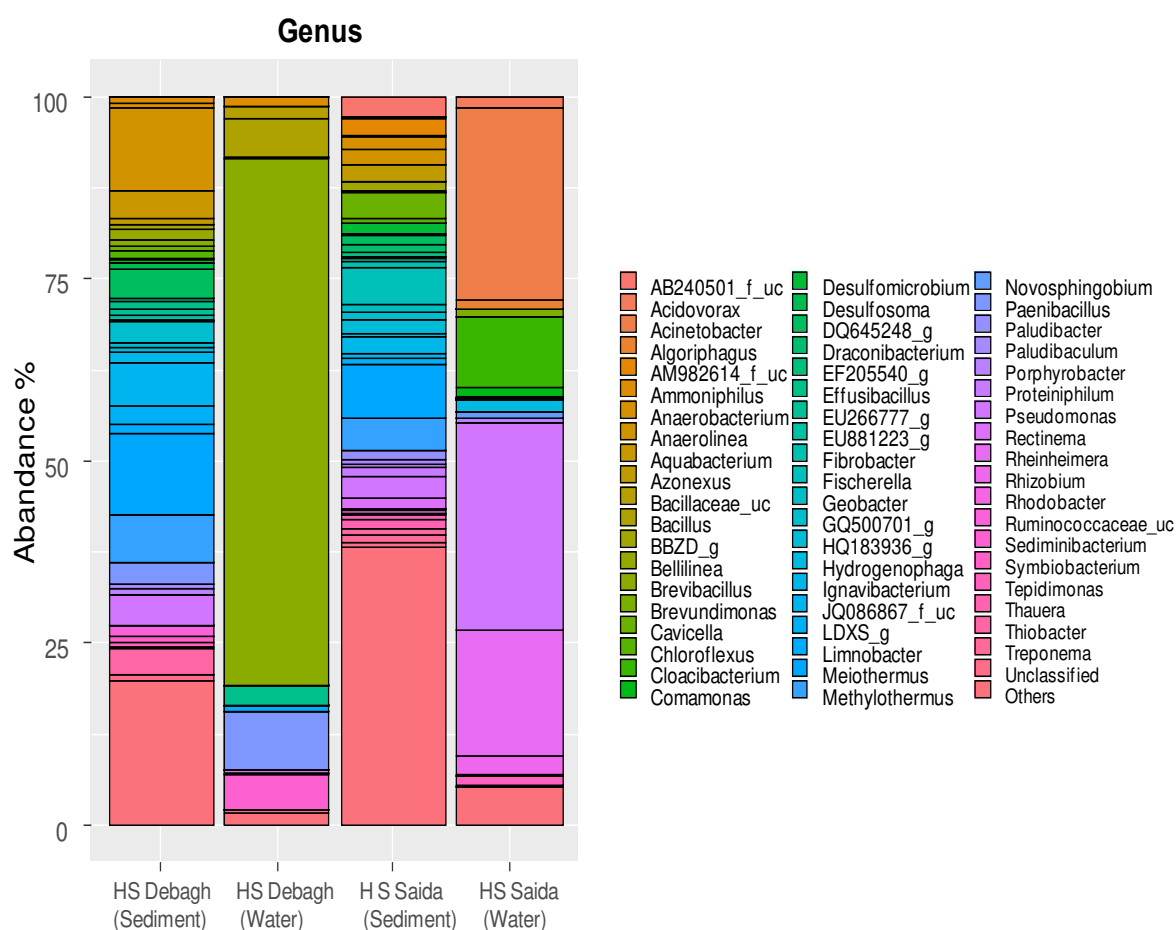

**Figure 10.** Relative abundance of bacterial genera in four samples from the two hot springs (Debagh and Saïda).

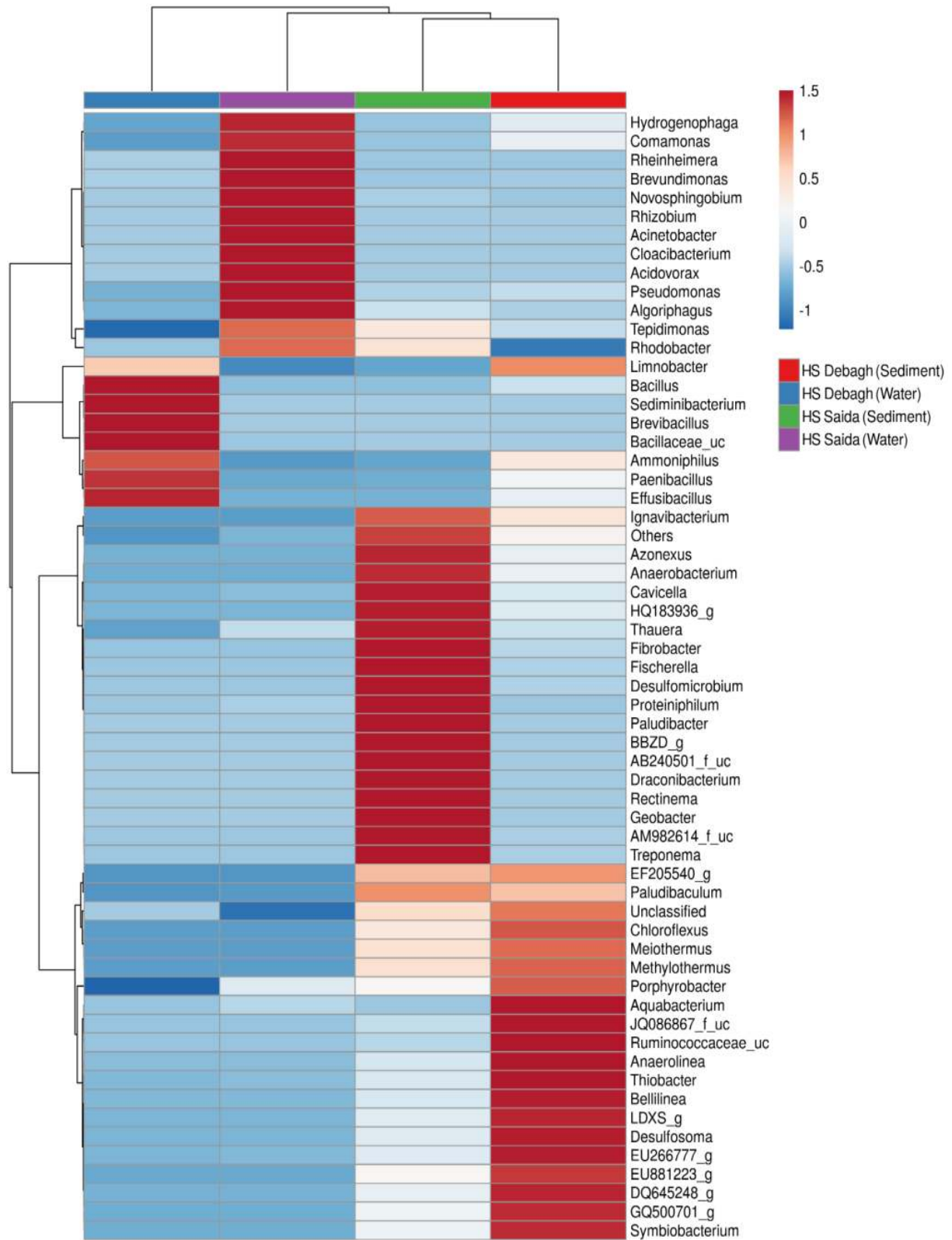

**Figure 11.** Heat map indicating the clustering of OTUs retrieved from the hot spring samples at the genus level. The color indicates the relative abundance of OTUs in the samples. The dendrograms show hierarchical clustering between the genus and the samples type.

## 5. Bacterial diversity analysis

The phylogenetic structure of a set of species can be described by different measures, which aim to inform about the degree of clustering, overdispersion, or randomness in the phylogenetic structure of an assemblage. The use of species variability summarizes the degree of phylogenetic relatedness among species in a group, considering all species or closest relatives. To (i) assess the composition of the microbial community and (ii) examine the influence of physicochemical parameters on diversity, the analysis of the alpha diversity, or the calculation of the species richness for all the samples was carried out. For this, we calculated the Shannon diversity indices ( $H'$ ,  $H'$  max), and the equitability) for each sample on both sides of the two hydrothermal sites.

The microbial complexities in the water and sediment were estimated based on the alpha-diversity indices (Chao1, Simpson, and Shannon). Species richness estimated with the Chao1 indices showed higher values in sediment samples rather than water samples (Tab. 2). Chao1, ACE, and Jackknife indices were higher at low-temperature conditions (H05S hot spring). Spring with a water temperature of 62°C had lower values than the second spring with about 96°C.

The evaluation of the species biodiversity within each sample type revealed Shannon–Weaver indices ( $H$ ) ranging between 1.86 for the water of H24D and 5.46 for sediment from the H05S hot spring (Tab. 2).  $H$  values determined for water H05S and sediment from H24D lie in-between values found at the water of H24D and sediment of H05S samples (2.57 and 4.68 respectively). These findings indicated an inversely proportional linear pattern between the Shannon–Weaver index and temperature.

The Shannon index gives an idea of the bacterial diversity, taking into account not only the number of species present but also the number of OTUs of the different species that make up the population. While the equitability index indicates that there is a balanced distribution of abundance between the bacterial populations detected in the samples and the variation of the equitability values roughly corresponds to those of the diversity.

At each sampling point of the two study sites (water and sediment), we determined species qualified as "unique or exclusive" when detected at a single sampling point and species termed as "common or shared" when found in at least two sampling points. Venn diagram exhibiting the distribution of shared OTUs across the hot springs and the sample types are shown in Figure 12.

**Table 2.** Estimated diversity indices for thermophilic bacteria from the two hot springs.

Diversity indices	Samples				
	HS Debagh (Sediment)	HS Saïda (Sediment)	HS Debagh (Water)	HS Saïda (Water)	
<b>Number of OTUs</b>	<b>632</b>	<b>1736</b>	<b>121</b>	<b>323</b>	
<b>Good's coverage library (%)</b>	99.4	99.1	99.9	99.6	
<b>ACE</b>	<b>LCI</b>	678.5	1952.2	122.7	403.9
	<b>Value</b>	<b>703.5</b>	<b>2005.4</b>	<b>131.7</b>	<b>445.7</b>
	<b>HCI</b>	731.6	2063.2	142.9	499.5
<b>Chao1</b>	<b>LCI</b>	655.3	1858.8	125.3	369.3
	<b>Value</b>	<b>670.7</b>	<b>1897.2</b>	<b>133.7</b>	<b>398.8</b>
	<b>HCI</b>	696.2	1947.6	158.2	447.2
<b>Jackknife</b>	<b>LCI</b>	742.0	2104.0	141.0	399.8
	<b>Value</b>	<b>742.0</b>	<b>2104.0</b>	<b>141.0</b>	<b>429.0</b>
	<b>HCI</b>	742.0	2104.0	141.0	458.2
<b>Shannon</b>	<b>LCI</b>	4.361	5.441	1.834	2.546
	<b>Value</b>	<b>4.378</b>	<b>5.460</b>	<b>1.858</b>	<b>2.569</b>
	<b>HCI</b>	4.414	5.479	1.882	2.593
<b>Simpson</b>	<b>LCI</b>	0.034	0.014	0.334	0.152
	<b>Value</b>	<b>0.035</b>	<b>0.014</b>	<b>0.340</b>	<b>0.154</b>
	<b>HCI</b>	0.036	0.014	0.347	0.157
<b>NPS Shannon</b>	<b>4.432</b>	<b>5.520</b>	<b>1.866</b>	<b>2.599</b>	
<b>Phylogenetic diversity</b>	<b>1133.0</b>	<b>2841.0</b>	<b>166.0</b>	<b>637.0</b>	

HS: Hot Spring.

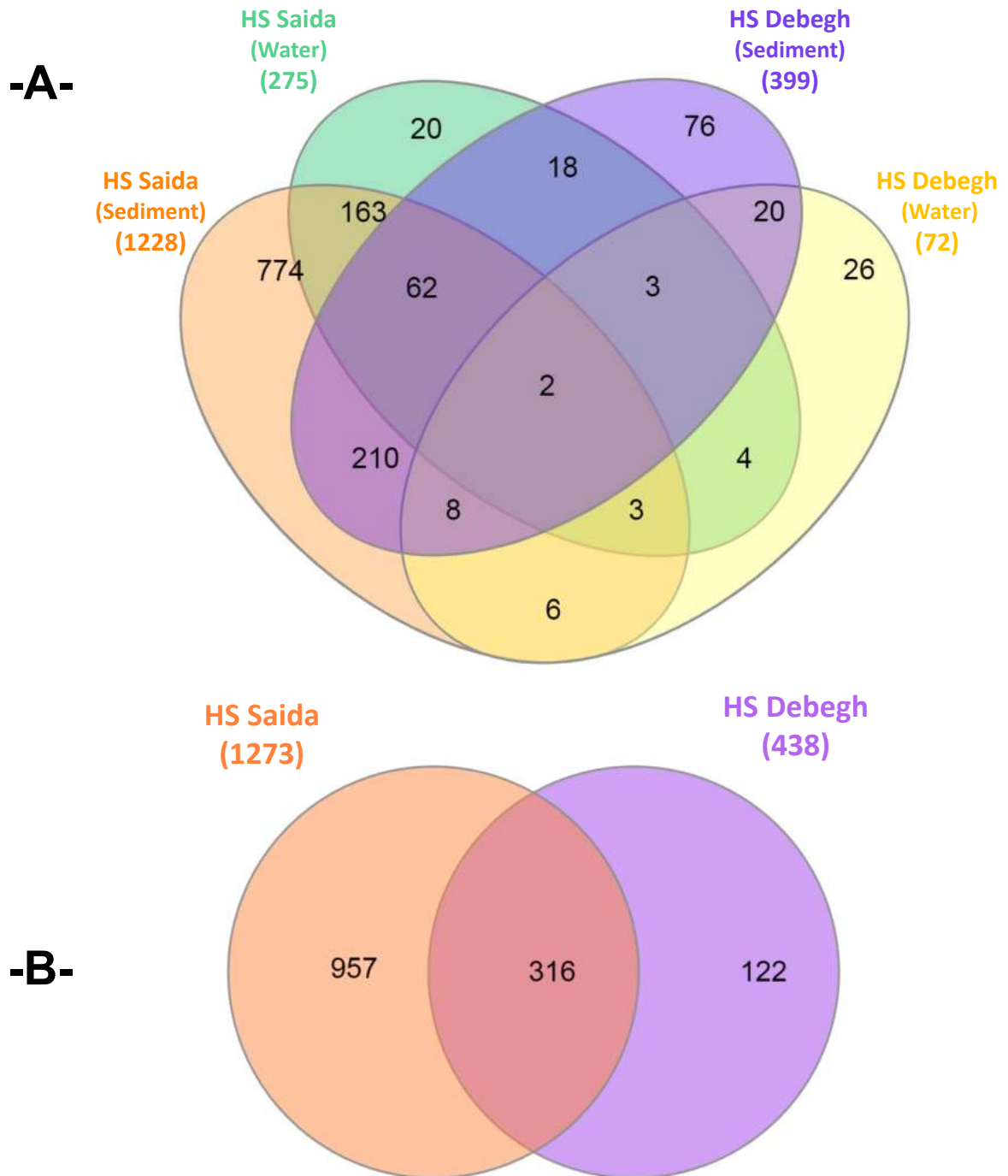

**Figure 12.** Venn diagram showing the distribution of unique and shared OTUs (A) within various sample types (B) within the two hot springs.

The Venn diagram in Figure 12 shows that Saïda hot spring is more diverse than Debagh hot spring in terms of exclusivity in the different sampled points. Larger proportions of OTUs were shared between the two hot springs (316 OTUs) in contrast to the four sample types (2 OTUs). The distribution of shared OTUs across the sample types revealed a greater overlap between sediment samples from H24D and H05S hot springs (210 OTUs). There was a relatively lower overlap between the microbial sediment and water sample types for both hot springs. In deposit, prokaryotic communities are more diverse than water, which could be related to the difference in physicochemical parameters between the two environments.

The rarefaction analysis was used to compare species richness and diversity between the four samples (Fig. 13). The curve displays the total number of annotated species as a function of the sampled sequences number. The rarefaction curves indicated that the bacterial libraries were tested below saturation, except for water samples from Debagh hot spring (Water: H24D) reaching a plateau. Thus, more sequences would be required for sediment from both sites and water from H05S to generate a stable estimate of species richness. This was also demonstrated by measured Chao1 values; estimated species richness for (sediments from Debagh and Saïda hot springs) and water from Saïda (H05S), which were nearly identical to the observed species richness ( $S$ ), but significantly higher for water samples from H24D hot spring.

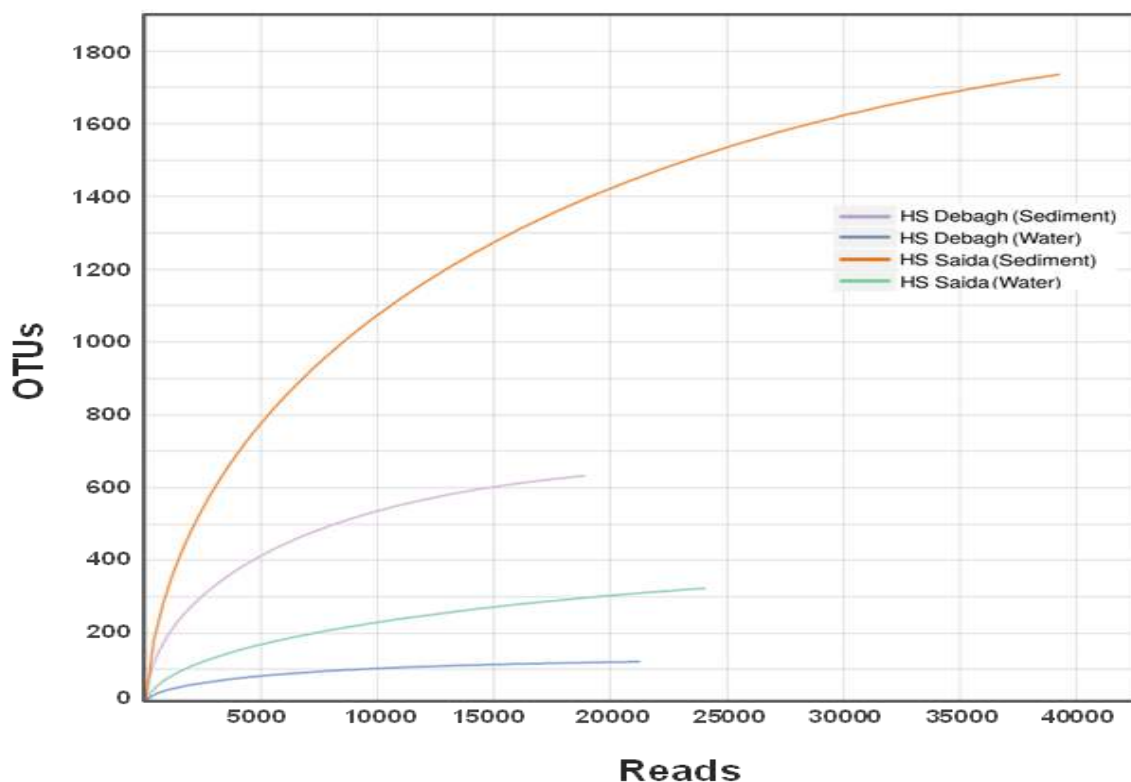

**Figure 13.** Rarefaction curves for the four samples from Debagh and Saïda hot springs.

The Shannon index values also corroborate these findings, indicating that the two hot springs were highly diversified. Despite incomplete sampling, the rarefaction curves revealed that bacterial richness increased as the study site's temperature decreased. This is consistent with previous research on other terrestrial hot springs worldwide, which found that lower temperatures resulted in a higher number of phylotypes (Tobler and Benning, 2011).

Both analyses, the rarefaction curve, and the indexes reveal that the sediment community from both sites presented much more alpha diversity (richness and evenness). As a result, both locations are likely to support more diversity than our study suggests. The recovery of phylotypes may be affected by factors such as primer and PCR/cloning bias (Lau *et al.*, 2009).

## 6. Correlation between microbial diversity and physicochemical parameters

In this study, we measured the chemistry parameters among hot spring waters. The different natures of the two ecosystems studied have a significant effect on their microbial biodiversity. The correlogram based on Pearson correlation revealed that the community composition was differentially correlated to various concerned geochemical parameters. Results showed that temperature played an important role in shaping and controlling microbial community composition at the phylum level; the same results were reported by many studies (Wang *et al.*, 2013).

The PCA of the hot springs divided the phyla into three groups visible on F1-F2 (100% of the total variance). Thus, the first axis explains the cumulative information (phyla/hot springs). Therefore, only this axis was considered in the interpretation of the results. The F1 axis explained 54.46% of the observed variations and clearly separated the two hot springs (Fig. 14). The Saída thermal spring positively influences the abundance of *Proteobacteria*, *Deinococcus-Thermus*, *Chlorobi*, and *Actinobacteria* species, while Debagh hot springs were dominated by *Firmicutes*, *Acidobacteria*, *Nitrospirae*, and *Spirochaetes*.

The relative abundance of *Proteobacteria* was positively correlated to the temperature, which was the most abundant phylum in Saída hot spring (H05S), in contrast to *Firmicutes*, the most generous in Debagh hot spring (H24D) shows negative correlation with temperature. However, the other phyla (*Deinococcus-Thermus*, *Actinobacteria*, *Spirochetes*, and *Nitrospirae*) did not establish a monotonic relationship to temperature changes (Fig. 15).

The existence of the *Proteobacteria* in hyperthermophilic hot springs could be an adaptation in low-nutrient conditions (Amin *et al.*, 2017). The other characteristic feature of phylum *Proteobacteria* is that they tolerate higher concentrations of sulfur and utilize sulfur as

an electron donor during their physiological growth (Najar *et al.*, 2018b). Therefore, it is not surprising that Saïda hot spring has a higher abundance of this phylum, as possessing high sulfur content of 414 mg/l (Tab. 1).

The temperature in the Saïda site was relatively lower as compared to the Debagh hot spring. This might have facilitated the survival of relatively mesophilic photosynthetic and photoautotrophic bacteria.

A negative correlation between the abundance of *Chlorobi* and *Chloroflexi* with temperature was observed consistent with their respective physiologies, explained by the restriction of photosynthesis when the temperature is higher than 75°C. These results are supported by earlier studies (Wang *et al.*, 2013; Badhai *et al.*, 2015).

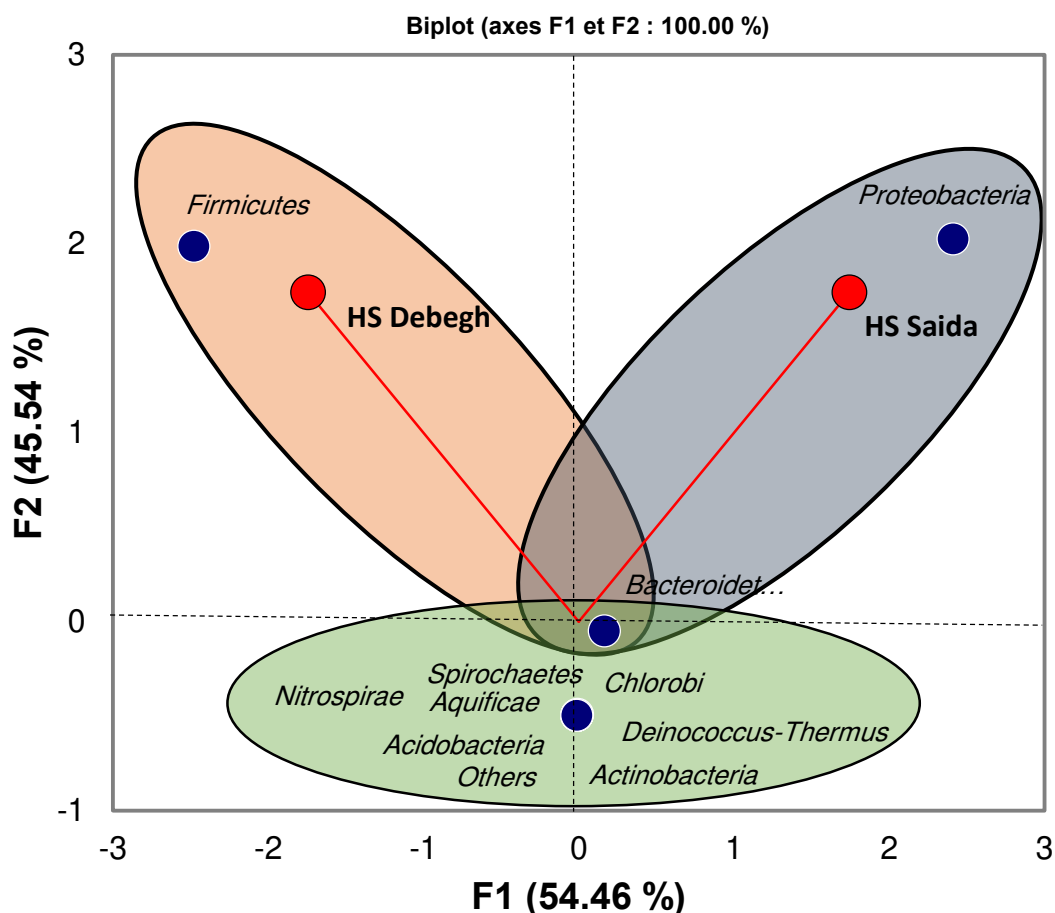

**Figure 14.** Principal coordinate analysis (PCA) illustrates the distribution of the major phyla among bacterial communities in the two hot springs.

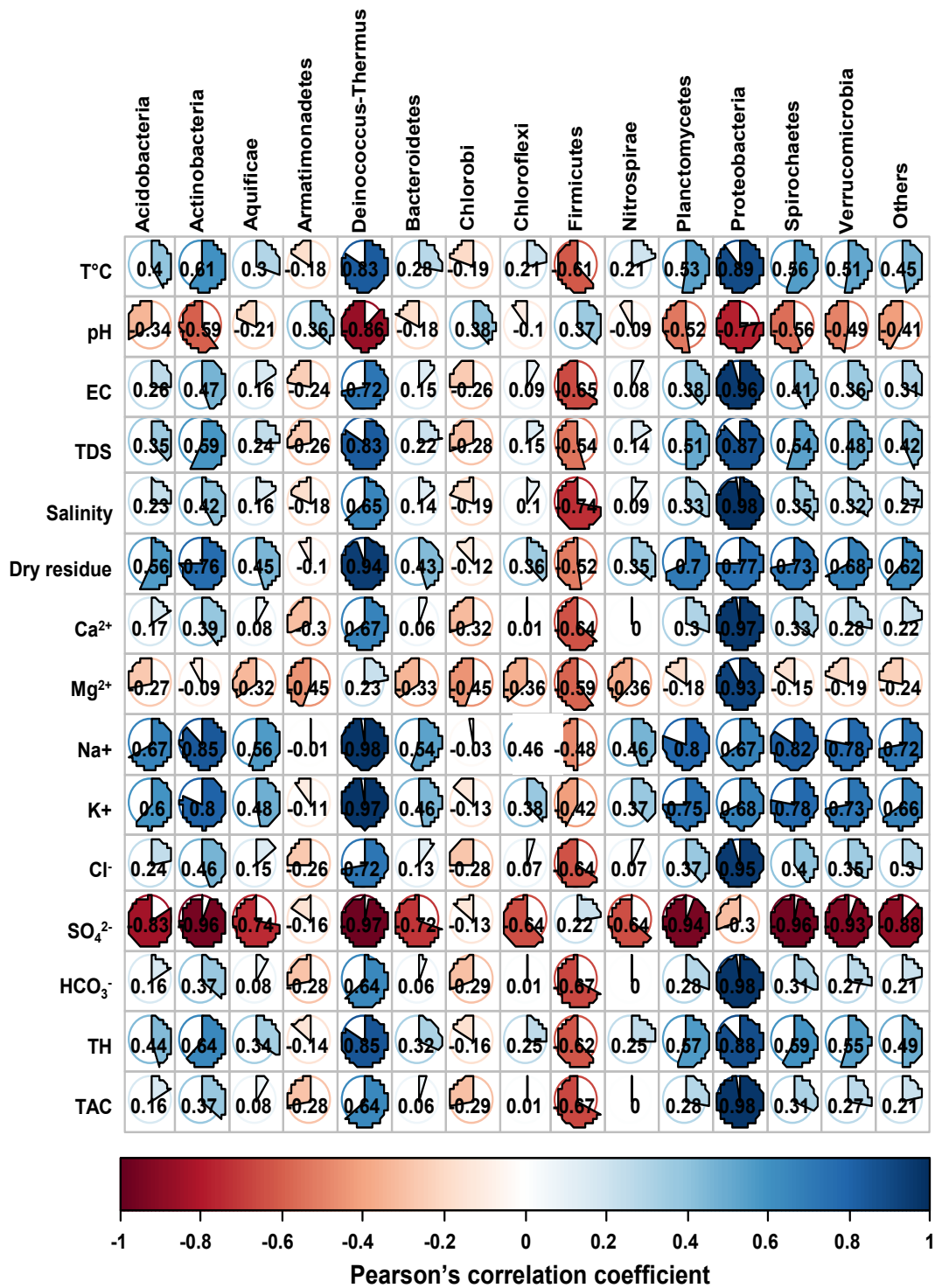

**Figure 15.** Correlogram based on Pearson correlation presenting the effect of physicochemical parameters on microbial composition and diversity.

While temperature appears to be the most important factor in determining the structure of bacterial diversity, specific populations can be affected by other factors, mainly sodium, potassium, and alkalinity. The relative abundance of *Actinobacteria*, *Deinococcus-Thermus*, *Planctomycetes*, and *Spirochetes* was strangely correlated to the aqueous concentrations of sodium and potassium, whereas, *Proteobacteria* was positively correlated with chloride, calcium, and magnesium.

The salinity, the dry residue, and the TDS were positively correlated to the relative abundance of several phyla, mainly; *Deinococcus-Thermus*, *Proteobacteria*, and *Actinobacteria*. It was also found that the pH did not affect the composition and distribution of the different phyla present in the two thermal springs.

Different mineralogy and geographical location between Debagh (H24D) and Saïda (H05S) hot springs may have contributed to the difference in microbial diversity between these two hydrothermal sites. The hot spring geochemical features may be critical aspects of community structure and diversity (López-López *et al.*, 2013).

The physicochemical characteristics of the site, such as pH, temperature, mineral, and other chemical profiles, have a direct effect on the microflora of the hot springs and also may play an essential role in the dispersal of biological functions and adaptive responses of the communities in these desirable habitats (Sharma *et al.*, 2020). It is important to remember that the chemical composition of thermal sources is determined by the chemical components of the surrounding rock materials and their chemical interactions with water (Celiker *et al.*, 2019).

These results suggest that the relationship between environmental parameters and microbial community structures could be a general pattern applicable to hot spring environments for predicting microbial diversity. This hypothesis should be confirmed by extending the current study to include other hydrothermal sites from Algeria, other than those in the Northeastern part of the country, or worldwide from a wide range of temperatures and water geochemistry.

# CONCLUSION

## CONCLUSION

The current research presents the first comprehensive whole-metagenomic profiling of two hot springs in the Northeastern region of Algeria located at different altitudes; Debagh hot spring (H24D) in Guelma City and Saïda hot spring (H05S) in Batna City. Comparing the prokaryotic biodiversity of the water and sediment of both hot springs showed two different ecological niches dominated by several species.

The metagenome sequence data revealed the dominance of *Bacteria* over *Archaea*. The most abundant phyla in Saïda hot spring were *Proteobacteria*, while Debagh hot spring showed a high relative abundance of *Firmicutes*. However, *Bacteroidetes* were nearly equally distributed over the two sites. Forty-nine prokaryotic phyla were detected, of which fourteen bacterial phyla showed relative ratios of  $\geq 1\%$ : *Acidobacteria*, *Armatimonadetes*, *Bacteroidetes*, *Chlorobi*, *Chloroflexi*, *Cyanobacteria*, *Deinococcus-Thermus*, *Fibrobacteres*, *Firmicutes*, *Nitrospirae*, *Proteobacteria*, *Spirochaetes*, *Verrucomicrobia*, and *JQ086867\_p*. Differential abundance of microbial species belonging to the *Proteobacteria*, *Firmicutes*, *Chloroflexi*, and *Deinococcus-Thermus* phyla reflected the difference in temperature and altitude of the thermal aquatic niches.

The Piper diagram shows that the two hot springs belong to different types of spring water; H05S belongs to the Na-SO<sub>4</sub> type while H24G has Ca-Cl-SO<sub>4</sub> chemical facies. Regarding the H24D hot spring, the findings indicate that the concentrations of major ions are higher than the norms. Consequently, the hydrothermal water is contraindicated for consumption, unlike Saïda hot spring, most physicochemical values of water were within the limit regarding WHO guidelines.

The composition of the microbial communities in these geothermal sites depended on environmental parameters such as temperature and ions concentrations. Furthermore, several unclassified bacteria and archaea were detected, suggesting a complex physiological mechanism in nature that needs further investigation. According to the correlation of physicochemical characteristics with the most dominant phyla, temperature, alkalinity, sodium, and potassium content shape the microbial population composition and diversity.

This study also demonstrated that a fuller understanding of the intricacy of geothermal microbial communities and their worldwide relevance could only be gained by investigating these relationships in many different sites using thorough geochemical, physical, and microbial investigations.

# GENERAL CONCLUSION AND PERSPECTIVES

## GENERAL CONCLUSION AND PERSPECTIVES

Exploring the biodiversity of hydrothermal environments identified in the Algerian territory is necessary to study the ecosystems they contain and exploit all the biotechnological potentialities they possess. Indeed, this would allow the discovery of novel taxa and new biotechnological assets that would be possible to use in various industrial applications.

The main objective of this research project was to explore the microbial diversity (eubacterial and archaeal) in natural terrestrial hydrothermal ecosystems (thermal springs) located in the Northeast of Algeria. Our approach was based on classical microbiological approaches depending on the isolation of thermophilic bacterial strains on multiple ordinary and selective media. In addition, a culture-independent strategy 'metagenomics' and high-throughput sequencing of amplicons of the V4 hypervariable region of the 16S rRNA gene was also performed.

To this purpose, water and sediment samples were collected and used for metagenomic study implicating total bacterial population analysis and to isolate cultivable thermophilic bacteria. Physicochemical parameters of water samples were determined to elucidate the characteristics and origin of these environments and their influence on the abundance and distribution of the thermal community among hot springs.

Great variability in the richness of thermophilic and thermotolerant eubacteria was noted according to sampling sites, the nature of the samples collected, and the culture media used for isolation. A total of 293 strains were isolated, of which 100 isolates were retained for molecular identification by 16S rRNA gene sequencing.

According to the sampled sites, there was much variation in thermophilic richness. These findings indicate that the strain distribution was heterogeneous, depending mainly on hot springs' temperature and physicochemical parameters. Water samples revealed 48.68 % isolates, whereas sediment samples from all hot springs provided 51.32 % isolates. There was no significant difference across sampling sites ( $p < 0.70$ ). On the other hand, sediment samples were more diversified; however, water samples revealed more stable culturable communities dominated by a low number of major representative species. The distribution of thermophilic bacteria according to isolation culture media showed a very highly significant effect. Indeed, specific media (Thermus medium, ATCC medium 697, and Thermus 162 medium) support the

growth of many thermophilic isolates with different morphological aspects. All the probably novel species were isolated on Thermus medium or Thermus 162 medium. While, TSA medium enhanced the isolation of the endospore-forming thermophilic bacteria (*Bacillus* and *Bacillus*-like-genera), representing the most abundant fraction among the identified isolates.

The physiological and morphological characteristics turned too difficult to differentiate isolates. The SDS-PAGE electrophoretic patterns of whole-cellular proteins from all isolates revealed that five groups could be distinguished at a 45% similarity level. One hundred representative strains from different clusters were selected for further molecular identification by 16 rRNA gene sequencing.

The results showed that all bacterial isolates belonged to three major phyla; *Firmicutes*, *Deinococcus-Thermus*, and *Actinobacteria*. The *Firmicutes* represented the most dominant group with 70.2%, including three families; *Bacillaceae* (71%), *Paenibacillaceae* (23%), and *Thermoactinomycetaceae* (6%), and different genera; *Bacillus* (30%), *Anoxybacillus* (17%), *Aneurinibacillus* 15% *Aeribacillus* (15%), *Brevibacillus* 8%, and *Thermoactinomyces* (5%). In contrast, the *Deinococcus-Thermus* was represented by a single-family *Thermaceae* affiliated with two genera *Meiothermus* and *Thermus*. Lastly, the *Actinobacteria* have been assigned to *Pseudonocardiaceae*, including the *Saccharomonospora* genera and *Nocardioseae* represented by *Thermobifida*.

Phylogenetic studies found that some isolates had relatively low similarity percentages for 16S rRNA with closely related species, suggesting the likelihood of new taxa. These isolates were further studied in polyphasic (*results in progress*). In conjunction, phenotypic and physiological analyses were performed to determine their exact taxonomic position. In total, seven strains that confirm the affiliation to *Bacillus*, *Brevibacillus*, *Geobacillus*, *Aneurinibacillus*, and *Thermoactinomyces* may probably constitute new taxa on these genera. Their sequences have been deposited in GenBank. However, according to the recent recommendations of the International Committee on Systematics of Prokaryotes (ICSP), the whole genome sequencing allows to accurately determine the taxonomic position of these isolates (*the complete genome sequencing of two strains is already done, bioinformatic analysis are in progress*). The results obtained indicate that the probable new species belonged to four different hot springs among the eight prospected and covers the four cities chosen for the study, which explains the richness of Algerian thermal springs in new taxa.

The enzymatic screening of thermophilic isolates indicates the production of a wide range of enzymes, mainly; amylase, cellulase, pectinase, esculinase, protease, gelatinase, lipase,

lecithinase, and nuclease activity. Among all thermophilic bacteria, 99.32% produced at least one extracellular hydrolytic enzyme. The combined hydrolytic activity was also detected in most strains. Indeed, 19 isolates (6.48%) combined all tested enzymes. Jointly 18.43% (54 isolates) and 15.36% (45 isolates) produced respectively four and six hydrolytic enzymes simultaneously. *Bacillus* spp. was the highest producer of all targeted enzymes, followed by *Anoxybacillus* spp., *Aneurinibacillus* spp., and *Aeribacillus* spp.

We employed culture-independent approaches to characterize the microbial diversity of two hot springs in Eastern Algeria. The composition and structure in concert with physicochemical environmental measurements allowed the assessment and prediction of parameters that may be essential in driving microbiology.

Our analysis identified an extraordinary number of deeply branching novel clades in both *Bacteria* and *Archaea* whose distribution is driven mainly by temperature. These observations suggest that this geographically isolated and environmentally extreme site contains unique lineages that may be localized to the site. The description of these areas and their physicochemical characterization are therefore important to better understand this diversity.

Exploring bacterial and archaeal diversity by sequencing amplicons of 16S rRNA genes amplified from metagenomic DNA allowed the identification of general and specific populations in these environments. Our results suggest that *Bacteria* are the most dominant taxa in the two hot springs. The minority fraction of *Archaea* was represented by three phyla, the obligately thermophilic *Crenarchaeota* (70.30%), the mesophilic *Crenarchaeota* called *Thaumarchaeota* (28.48%), and *Euryarchaeota* (1.21%). Over 50.90% of sequences have been affiliated with the *Thermoproteales*, in addition to some minor order like *Desulfurococcales* (09.09%) and other unclassified sequences. The *Archaeal* sequences that remained unclassified at the phylum level were 66.73%, distributed as follows 24.05% in Debagh hot spring and 86.68% in Saïda hot spring. The *Archeal* diversity requires further investigation using more specific primers.

In addition, 49 different bacterial phyla were detected in the two hot springs, where *Proteobacteria*, *Firmicutes*, *Bacteroidetes*, *Cyanobacteria*, and *Deinococcus-Thermus* were the most abundant taxa. Low abundance groups such as *Acidobacteria*, *Verrucomicrobia*, *Nitrospirae*, and *Spirochaetes* with other rarer phyla were also identified. The various samples revealed a succession of different phyla, ranging from hyperthermophiles to moderate thermophiles and mesophiles. Saïda hot spring (H05S) is a valuable resource for mesophiles

and moderate thermophiles, according to the current whole-metagenomic analysis, while hyperthermophiles dominate Debagh hot spring (H24D).

In the present study, the culture-dependent taxonomic profiling showed the dominance of Gram-positive bacteria over Gram-negative in the hot springs. However, the NGS data was relatively different from the culture-dependent approach. The dominant bacterial phylotypes in the metagenome library were Gram-negative (*Proteobacteria*) over Gram-positive bacteria (*Firmicutes*). The ubiquitous nature of the phylum *Firmicutes* (the dominant phyla in the culture-dependent study from chapter 1) and their capacity to adapt to a wide range of temperature, pH, and salinity renders them robust and culturable. However, the overwhelming presence of the unculturable Gram-negative bacteria (*Proteobacteria*) in the environment masked the dominance of Gram-positive bacteria.

The physicochemical analyses of the water from the two hot springs have shown that the Debagh hot spring (H24D) was slightly acidic, hyperthermophilic, and moderately saline. In contrast, Saïda hot spring (H05S) was moderately alkaline, hyperthermophilic, and slightly saline. The Pearson correlation matrix shows a strong correlation between Cl, Ca, K, Na, and TDS, indicating that this anion and cations mainly influence the hot spring water mineralization.

The Piper and Schöeller-Berkaloff diagrams allowing classification of the hot springs water based on chemical composition indicates that the two hot springs belong to different types of spring water. Saïda (H05S) belongs to the sodium-sulfate type, reasoning that the reservoir water-rock interaction consists essentially of sands, sandstones, gypsum, and a small clay fraction and the dissolution of gypsum anhydrite, and sulfides oxidation. However, Debagh (H24G) has Ca-Cl-SO<sub>4</sub> chemical facies, confirming the water interaction with carbonate minerals and their dissolution and depositional processes since the country's northeastern region consists of mainly carbonate reservoirs rock formations.

Regarding thermal water drinkability, Debagh hot spring findings indicate that the concentrations of major ions exceeding WHO standards; consequently, this water is contraindicated for consumption which should be mentioned for spa users in this region, while Saïda hot spring water physicochemical values were within the limit, which results that spring water is safe for drinkability or industrial exploitation without any special precautions.

The correlation and relationship between microbial communities and physicochemical parameters among the two hot springs water were performed. The physicochemical characteristics

of the sites, mainly temperature, alkalinity, and aqueous concentrations of ions such as sodium, and potassium have demonstrated a direct effect on the microflora diversity.

The bacterial diversity analysis based on alpha-diversity indices proved higher complexity and diversity in sediments than water samples. However, our findings indicated an inversely proportional linear pattern between diversity and temperature. These data have been confirmed by the results of the Venn diagram showing that Saïda hot spring (62°C) is more diverse than the Debagh hot spring (98°C) in terms of species exclusivity in the different sampled points. The rarefaction curves analysis indicates that both hot springs support more diversity than our study suggests. This was also demonstrated by Chao1 values. The recovery of more phylotypes may be affected by improving several factors such as sampling methods, primers, and PCR/cloning bias.

The biochemical and physiological characterization has certain constraints in the classification of isolates, as it is difficult to differentiate closely related bacteria. As part of a polyphasic taxonomic procedure, molecular identification is more reliable and could contribute to the conclusive identification of isolates.

The SDS-PAGE results allow clustering the isolates and may eliminate redundant species during the bioprospecting process, especially when many samples require screening, enabling rapid, lower cost, and easy discrimination as the first step for mandatory molecular identification. According to our findings, SDS-PAGE profiling could be an interesting tool for prospecting new strains of thermophilic bacteria.

The culture-dependent approach has proved effective in identifying the biochemical and physiological features of pure cultures, as well as developing whole-cell applications. However, cultivable thermophilic bacteria may not represent the natural microbiota since these species represent a minority of those present. The inability of traditional culture-based methods to describe the vast diversity in the hidden microbial world has forced a shift to culture-independent metagenomics approaches that complement physiological analyses to explore functional and taxonomic diversity in hot springs effectively.

Understanding microbial community dynamics and genomic variability of community members in hot springs with various ecologies is essential to highlight community functions and their importance for maintaining these ecosystems.

Our knowledge about the nature and distribution of bacteria in these thermophilic ecosystems is probably still unknown. The combined use of metagenomic and cultural

techniques has shown that these environments have revealed an unexpected diversity of microorganisms, particularly thermophilic bacteria and archaea. However, several perspectives are considered as a continuation of this work:

- Application of other isolation methods with different conditions could target much more species and specific metabolisms (e.g., autotrophy) compared to heterotrophs,
- The valorization of different extreme biotopes by diversifying the samples, and also the isolation culture media,
- The use of enrichment cultures with low or even deficient nutrient concentrations (oligotrophic conditions) or in the presence of growth factors could be an effective strategy to limit the growth of heterotrophs and thus increase microbial diversity by accessing new microorganisms and taxa that are still 'uncultivated' but probably not uncultivable from thermophilic ecosystems,
- The use of more specific nucleic probes (of a class, order, family, or even a genus) would allow to follow more precisely certain microbial populations within a community or to use them for enumeration and detection of metabolically active bacterial populations,
- The use of genetic fingerprinting methods and oligonucleotides targeting genes coding for key enzymes of specific metabolic pathways may allow detection of community population potentially associated with a targeted function (e.g., active substances),
- All the probably novel strains need to be further characterized by the whole genome sequencing, G+C content, fatty acid and polar lipid analysis (*in progress*),
- Identification of all the *Aeribacillus* strain through DNA-DNA hybridization,
- Production and purification of detected extracellular enzymes from strains of interest and characterization of their enzymatic properties,
- Further research could focus on metagenomic sequencing of bacteria in other hot springs with potentially interesting characteristics. Additional differentially variable regions (V1–V9) can also be targeted for sequencing,
- The use of metaomic approaches (genomics, transcriptomics, proteomics, and metabolomics) for direct exploration of hydrolytic enzymes and bioactive substances of biotechnological interest.

# REFERENCES

- Aanniz, T., Ouadghiri, M., Melloul, M., Swings, J., Elfahime, E., Ibjibijen, J., Ismaili, M., Amar, M., 2015. Thermophilic bacteria in moroccan hot springs, salt marshes and desert soils. *Brazilian J. Microbiol.* 46, 443–453. <https://doi.org/10.1590/S1517-838246220140219>
- Adiguzel, A., Ozkan, H., Baris, O., Inan, K., Gulluce, M., Sahin, F., 2009. Identification and characterization of thermophilic bacteria isolated from hot springs in Turkey. *J. Microbiol. Methods* 79, 321–328. <https://doi.org/10.1016/j.mimet.2009.09.026>
- Adjeroud, M., Escuder-Rodríguez, J.J., González-Siso, M.I., Kecha, M., 2020. Metagenomic investigation of bacterial and archaeal diversity of hammam essalihine hot spring from Khenchela, Algeria. *Geomicrobiol. J.* 37 (9), 1–14. <https://doi.org/10.1080/01490451.2020.1783035>
- Agilent, 2017. Flame atomic absorption spectrometry. *Analytical Methods*. 14<sup>th</sup> edition, Agilent Technologies Australia (M). [www.agilent.com](http://www.agilent.com).
- Aksakal, A., 2010. Analysis of whole-cell protein profiles of *Salmonella* serovars isolated from chicken, turkey and sheep faeces by SDS-PAGE. *Vet. Med.* 55, 259–263. <https://doi.org/10.17221/2986-VETMED>
- Al-Bader, D., Eliyas, M., Rayan, R., Radwan, S., 2012. Air-dust-borne associations of phototrophic and hydrocarbon-utilizing microorganisms: Promising consortia in volatile hydrocarbon bioremediation. *Environ. Sci. Pollut. Res.* 19, 3997–4005. <https://doi.org/10.1007/s11356-012-0897-x>
- Albuquerque, L., Rainey, F.A., Costa, M.S., 2018a. *Thermus*, in: *Bergey's Manual of Systematics of Archaea and Bacteria*. pp. 1–39. <https://doi.org/10.1002/9781118960608.gbm00477.pub2>
- Albuquerque, L., Rainey, F.A., Costa, M.S., 2018b. *Meiothermus*, in: *Bergey's Manual of Systematics of Archaea and Bacteria*. pp. 1–28. <https://doi.org/10.1002/9781118960608.gbm00476.pub2>
- Altschul, S.F., Madden, T.L., Schäffer, A.A., Zhang, J., Zhang, Z., Miller, W., Lipman, D.J., 1997. Gapped BLAST and PSI-BLAST: a new generation of protein database search programs. *Nucleic Acids Res.* 25, 3389–402. <https://doi.org/10.1093/nar/25.17.3389>
- Amarouche-Yala, S., Benouadah, A., El Ouahab Bentabet, A., López-García, P., 2014. Morphological and phylogenetic diversity of thermophilic *Cyanobacteria* in Algerian hot springs. *Extremophiles* 18, 1035–1047. <https://doi.org/10.1007/s00792-014-0680-7>
- Amarouche-Yala, S., Benouadah, A., El Ouahab Bentabet, A., Moulla, A.S., Ouarezki, S.A., Azbouche, A., 2015. Physicochemical, bacteriological, and radiochemical characterization of some Algerian thermal spring waters. *Water Qual. Expo. Heal.* 7, 233–249. <https://doi.org/10.1007/s12403-014-0130-x>
- Amend, J., 2001. Energetics of overall metabolic reactions of thermophilic and hyperthermophilic *Archaea* and *Bacteria*. *FEMS Microbiol. Rev.* 25, 175–243. [https://doi.org/10.1016/S0168-6445\(00\)00062-0](https://doi.org/10.1016/S0168-6445(00)00062-0)
- Amin, A., Ahmed, I., Salam, N., Kim, B.Y., Singh, D., Zhi, X.Y., Xiao, M., Li, W.J., 2017. Diversity and distribution of thermophilic bacteria in hot springs of Pakistan. *Microb. Ecol.* 74, 116–127. <https://doi.org/10.1007/s00248-017-0930-1>
- Antranikian, G., 2008. Industrial relevance of thermophiles and their enzymes. In: Robb F., Antranikian G., Grogan D., Driessen A. *Thermophiles: biology and technology at high temperatures*. 1<sup>st</sup> edition CRC Press
- APHA, 2005. American Public Health Association: Standard methods for examination of water

- and wastewater, 21<sup>st</sup> edition. APHA, AWWA, WPCF, Washington.
- APHA, 2018. “2320 Alkalinity”, Standard methods for the examination of water and wastewater. <https://doi.org/10.2105/SMWW.2882.023>
- Arab, M., Bakour, S., Lalaoui, R., Aissaoui, N., Nas, F., Hoceini, A., Fournier, P., Klouche-khelil, N., 2018. Diversity of aerobic *Bacilli* analysis using molecular and culture-based approaches in Debagh hot spring. *Geomicrobiol. J.* 36 (2), 1–11. <https://doi.org/10.1080/01490451.2018.1520937>
- Archna, S., Priyank, V., Nath, Y.A., Kumar, S.A., 2015. Bioprospecting for extracellular hydrolytic enzymes from culturable thermotolerant bacteria isolated from Manikaran thermal springs. *Res. J. Biotechnol.* 10, 33–42.
- Arya, M., Joshi, G.K., Gupta, A.K., Kumar, A., Raturi, A., 2015. Isolation and characterization of thermophilic bacterial strains from Soldhar (Tapovan) hot spring in Central Himalayan Region, India. *Ann. Microbiol.* 65, 1457–1464. <https://doi.org/10.1007/s13213-014-0984-y>
- Athamena, A., Athamena, M., Djaiz, F., 2015. Géothermie des eaux souterraines, Cas de la source thermale de Guerdjima, Batna Est Algérien. Theme 4 : Ressources en eau et Hydrogéologie. 22<sup>ème</sup> Colloque International des Bassins Sédimentaires, Fes 18-20 decembre 2015. Morocco.
- Atlas, R.M., 2005. Handbook of media for environmental microbiology, handbook of media for environmental microbiology. CRC Press. <https://doi.org/10.1201/9781420037487>
- Ay Sal, F., Colak, D.N., Guler, H.I., Canakci, S., Belduz, A.O., 2019. Biochemical characterization of a novel thermostable feruloyl esterase from *Geobacillus thermoglucosidasius* DSM 2542T. *Mol. Biol. Rep.* 46, 4385–4395. <https://doi.org/10.1007/s11033-019-04893-6>
- Badhai, J., Ghosh, T.S., Das, S.K., 2015. Taxonomic and functional characteristics of microbial communities and their correlation with physicochemical properties of four geothermal springs in Odisha, India. *Front. Microbiol.* 6, 1166. <https://doi.org/10.3389/fmicb.2015.01166>
- Bahri, F., Saibi, H., Cherchali, M.E.H., 2011a. Characterization, classification, and determination of drinkability of some Algerian thermal waters. *Arab. J. Geosci.* 4, 207–219. <https://doi.org/10.1007/s12517-010-0127-0>
- Baltaci, M.O., Genc, B., Arslan, S., Adiguzel, G., Adiguzel, A., 2017. Isolation and characterization of thermophilic bacteria from geothermal areas in Turkey and preliminary research on biotechnologically important enzyme production. *Geomicrobiol. J.* 34, 53–62. <https://doi.org/10.1080/01490451.2015.1137662>
- Barer, M.R., 2012. Bacterial growth, physiology and death, *Medical Microbiology*. 18<sup>th</sup> edition. Elsevier Ltd. <https://doi.org/10.1016/B978-0-7020-4089-4.00019-6>
- Battista, J.R., Rainey, F.A., 2015. *Deinococcus*, in: *Bergey’s Manual of Systematics of Archaea and Bacteria*. pp. 1–13. <https://doi.org/10.1002/9781118960608.gbm00475>
- Bekkouche, M.F., 2016. Caractéristiques hydro-chimiques des sources thermales de l’extrême Nord-Est Algérien. Ph.D. Thesis in Hydrogeology, University Badji Mokhtar-Annaba, Algeria. pp. 230
- Belduz, A.O., Dulger, S., Demirbag, Z., 2003. *Anoxybacillus gonensis* sp. nov., a moderately thermophilic, xylose-utilizing, endospore-forming bacterium. *Int. J. Syst. Evol. Microbiol.* 53, 1315–1320. <https://doi.org/10.1099/ijs.0.02473-0>
- Benammar, L., İnan Bektaş, K., Menasria, T., Beldüz, A.O., Güler, H.I., Bedaida, I.K.,

- Gonzalez, J.M., Ayachi, A., 2020. Diversity and enzymatic potential of thermophilic bacteria associated with terrestrial hot springs in Algeria. *Brazilian J. Microbiol.* 51, 1987–2007. <https://doi.org/10.1007/s42770-020-00376-0>
- Benammar, L., Menasria, T., Chergui, A., Benfiala, S., Ayachi, A., 2017. Indoor fungal contamination of traditional public baths (Hammams). *Int. Biodeterior. Biodegrad.* 117, 115–122. <https://doi.org/10.1016/j.ibiod.2016.12.004>
- Bendia, A.G., Araujo, G.G., Pulschen, A.A., Contro, B., Duarte, R.T.D., Rodrigues, F., Galante, D., Pellizari, V.H., 2018. Surviving in hot and cold: psychrophiles and thermophiles from Deception Island volcano, Antarctica. *Extremophiles* 22, 917–929. <https://doi.org/10.1007/s00792-018-1048-1>
- Bennett, A.C., Murugapiran, S.K., Hamilton, T.L., 2020. Temperature impacts community structure and function of phototrophic *Chloroflexi* and *Cyanobacteria* in two alkaline hot springs in Yellowstone National Park. *Environ. Microbiol. Rep.* 12, 503–513. <https://doi.org/10.1111/1758-2229.12863>
- Bhandari, S., Nailwal, T.K., 2020. Exploration of microbial communities of Indian hot springs and their potential biotechnological applications, *Recent Advancements in Microbial Diversity*. Elsevier Inc. <https://doi.org/10.1016/b978-0-12-821265-3.00011-6>
- Bhandiwad, A., Shaw, A.J., Guss, A., Guseva, A., Bahl, H., Lynd, L.R., 2014. Metabolic engineering of *Thermoanaerobacterium saccharolyticum* for n-butanol production. *Metab. Eng.* 21, 17–25. <https://doi.org/10.1016/j.ymben.2013.10.012>
- Birnboim, H.C., Doly, J., 1979. A rapid alkaline extraction procedure for screening recombinant plasmid DNA. *Nucleic Acids Res.* 7(6), 1513–1523. <https://doi.org/10.1093/nar/7.6.1513>
- Bonnet, M., Lagier, J.C., Raoult, D., Khelaifia, S., 2020. Bacterial culture through selective and non-selective conditions: the evolution of culture media in clinical microbiology. *New Microbes New Infect.* 34, 100622. <https://doi.org/10.1016/j.nmni.2019.100622>
- Boone, D.R., 2015. *Methanothermobacter*, in: *Bergey's Manual of Systematics of Archaea and Bacteria*. pp. 1–8. <https://doi.org/10.1002/9781118960608.gbm00498>
- Boufassa, S., 2018. Architecture des établissements thermaux en Algérie durant le XIXe siècle : Reflet ethnocentrique du système colonial. *Studi di Storia Contemporanea.* 33 (1). <https://doi.org/10.4000/diacronie.7283>
- Boukhenfouf, W., Boucenna, A., 2019. Comparison of the radio-isotopic composition between hot spring water of Hammam Debagh and its associated deposits. *Radiat. Prot. Dosimetry* 187, 369–377. <https://doi.org/10.1093/rpd/ncz177>
- Bozdağ, A., Göçmez, G., 2013. Evaluation of groundwater quality in the Cihanbeyli basin, Konya, Central Anatolia, Turkey. *Environ. Earth Sci.* 69, 921–937. <https://doi.org/10.1007/s12665-012-1977-4>
- Bradford, M.M., 1976. A rapid and sensitive method for the quantitation of microgram quantities of protein utilizing the principle of protein-dye binding. *Anal. Biochem.* 72, 248–254. [https://doi.org/10.1016/0003-2697\(76\)90527-3](https://doi.org/10.1016/0003-2697(76)90527-3)
- Brinis, N., 2011. Caractérisation de la salinite d'un complexe aquifère en zone aride cas de l'aquifère d'El-Outaya région nord-ouest de Biskra. Algérie. Ph.D. Thesis in Hydrology. University of Biskra, Algeria. pp. 252
- Brock, T.D., 1978. *Thermophilic microorganisms and life at high temperatures*. Springer, Berlin Heidelberg, New York. pp. 11–38.
- Brock, T.D., Freeze, H., 1969. *Thermus aquaticus* gen. n. and sp. n., a nonsporulating extreme thermophile. *J. Bacteriol.* 98, 289–297.

- Burgess, S.A., Flint, S.H., Lindsay, D., Cox, M.P., Biggs, P.J., 2017. Insights into the *Geobacillus stearothermophilus* species based on phylogenomic principles. *BMC Microbiol.* 17, 1–12. <https://doi.org/10.1186/s12866-017-1047-x>
- Capece, M.C., Clark E., Saleh, J.K., Halford, D., Heintz, N., Hoskins, S. Rothschild, L.J., 2013. Polyextremophiles and the constraints for terrestrial habitability. In: Seckbach J., Oren A., Stan-Lotter, H. *Polyextremophiles: life under multiple forms of stress*. Springer, Dordrecht. <https://doi.org/10.1007/978-94-007-6488-0>.
- Castany, G., 1963. *Traité pratique des eaux souterraines [Practical aspect of groundwaters]*. Dunod. Paris, France.
- Castenholz, R.W., 1970. Thermophilic blue-green algae and the thermal environment. *Bacteriol. Rev.* 34, 215–215. <https://doi.org/10.1128/mmbr.34.2.215-215.1970>
- Chan, C.S., Chan, K.G., Tay, Y.L., Chua, Y.H., Goh, K.M., 2015. Diversity of thermophiles in a Malaysian hot spring determined using 16S rRNA and shotgun metagenome sequencing. *Front. Microbiol.* 6, 1–15. <https://doi.org/10.3389/fmicb.2015.00177>
- Celiker, M., Dursun, O.F., Firat, M. 2019. Hydro-chemical and isotopic investigation of the İspendere mineral and thermal water springs, Malatya. *Turkey Maden Tetkik ve Arama Dergisi.* 158:311–25
- Chun, J., Lee, J.H., Jung, Y., Kim, M., Kim, S., Kim, B.K., Lim, Y.W., 2007. EzTaxon: A web-based tool for the identification of prokaryotes based on 16S ribosomal RNA gene sequences. *Int. J. Syst. Evol. Microbiol.* 57, 2259–2261. <https://doi.org/10.1099/ijs.0.64915-0>
- Clarridge-Jill, E., 2004. Impact of 16S rRNA gene sequence analysis for identification of bacteria on clinical microbiology and infectious diseases impact of 16S rRNA gene sequence analysis for identification of bacteria on clinical microbiology and infectious diseases. *Clin. Microbiol. Rev.* 17, 840–862. <https://doi.org/10.1128/CMR.17.4.840>
- Colak, D.N., Inan, K., Karaoglu, H., Canakcı, S., Belduz, A.O., 2012. Molecular analysis of the genus *Anoxybacillus* based on sequence similarity of the genes *recN*, *flaA*, and *ftsY*. *Folia Microbiol. (Praha).* 57, 61–69. <https://doi.org/10.1007/s12223-011-0094-1>
- Colwell, R.K., Elsensohn, J.E., 2014. EstimateS turns 20: Statistical estimation of species richness and shared species from samples, with non-parametric extrapolation. *Ecography (Cop.)*. 37, 609–613. <https://doi.org/10.1111/ecog.00814>
- Contesini, F.J., Melo, R.R. de, Sato, H.H., 2018. An overview of *Bacillus* proteases: from production to application. *Crit. Rev. Biotechnol.* 38, 321–334. <https://doi.org/10.1080/07388551.2017.1354354>
- Corwin, D.L., Yemoto, K., 2017. Salinity: electrical conductivity and total dissolved solids. *Methods Soil Anal.* 84(5), 1442–1461. <https://doi.org/10.2136/msa2015.0039>
- Costa, M.S., Rainey, F.A., Albuquerque, L., 2018. *Thermaceae*, in: *Bergey's Manual of Systematics of Archaea and Bacteria*. pp. 1–2. <https://doi.org/10.1002/9781118960608.fbm00093.pub2>
- Costas, M., Holmes, B., Sloss, L.L., 1990. Comparison of SDS–PAGE protein patterns with other typing methods for investigating the epidemiology of ‘*Klebsiella aerogenes*.’ *Epidemiol. Infect.* 104, 455–465. <https://doi.org/10.1017/S0950268800047464>
- Coughlan, L.M., Cotter, P.D., Hill, C., Alvarez-ordóñez, A., Kelly, W.J., Mora, D., 2015. Biotechnological applications of functional metagenomics in the food and pharmaceutical industries 6, 1–22. <https://doi.org/10.3389/fmicb.2015.00672>
- Da Costa, M.S., Rainey, F.A., Nobre, M.F., 2006. The Genus *Thermus* and Relatives. In:

- Dworkin, M., Falkow, S., Rosenberg, E., Schleifer, K.H., Stackebrandt, E. The Prokaryotes. Springer, New York, NY. [https://doi.org/10.1007/0-387-30747-8\\_32](https://doi.org/10.1007/0-387-30747-8_32)
- Das, S., Dash, H., 2015. Cloning and transformation. In: Microbial biotechnology- A laboratory manual for bacterial systems. Springer, New Delhi. <https://doi.org/10.1007/978-81-322-2095-4>
- Davis, K.E.R., Joseph, S.J., Janssen, P.H., 2005. Effects of growth medium, inoculum size, and incubation time on culturability and isolation of soil bacteria. *Appl. Environ. Microbiol.* 71, 826–834. <https://doi.org/10.1128/AEM.71.2.826-834.2005>
- De León, K.B., Gerlach, R., Peyton, B.M., Fields, M.W., 2013. Archaeal and bacterial communities in three alkaline hot springs in Heart Lake Geyser Basin, Yellowstone National Park. *Front. Microbiol.* 4, 1–10. <https://doi.org/10.3389/fmicb.2013.00330>
- de Souza, P.M., de Oliveira Magalhães, P., 2010. Application of microbial  $\alpha$ -amylase in industry - a review. *Brazilian J. Microbiol.* 41, 850–861. <https://doi.org/10.1590/s1517-83822010000400004>
- de Souza, Y.P.A., Rosado, A.S., 2018. Opening the black box of thermophilic autotrophic bacterial diversity, microbial diversity in the genomic era. Elsevier Inc. <https://doi.org/10.1016/b978-0-12-814849-5.00019-8>
- Degryse, E., Glansdorff, N., Piérard, A., 1978. A comparative analysis of extreme thermophilic bacteria belonging to the genus *Thermus*. *Arch. Microbiol.* 117, 189–196. <https://doi.org/10.1007/BF00402307>
- Denner, E.B.M., Kämpfer, P., Busse, H., 2015. *Thermomonas*, in: *Bergey's Manual of Systematics of Archaea and Bacteria*. pp. 1–6. <https://doi.org/10.1002/9781118960608.gbm01238>
- Djokic, T., VanKranendonk, M.J., Campbel, K.A., Walter, M.R., Ward, C.R., 2017. Earliest signs of life on land preserved in ca. 3.5 Ga hot spring deposits. *Nat. Commun.* 8, 1–8. <https://doi.org/10.1038/ncomms15263>
- D'Souza, D.R., Kaur, R., Pajni, S., Sharma, P., 1997. Isolation of thermophilic bacteria using bacteriological grade agar at temperatures above 80°C. *Biotechniques* 22, 1078. <https://doi.org/10.2144/97226bm14>
- Earle, S., 2019. Earth's interior (Chapter 9). In: Earle, S., *Physical Geology*. 2<sup>nd</sup> edition. BCcampus Open Ed.
- Edgar, R.C., 2013. UPARSE: Highly accurate OTU sequences from microbial amplicon reads. *Nat. Methods* 10, 996–998. <https://doi.org/10.1038/nmeth.2604>
- Edgar, R.C., 2010. Search and clustering orders of magnitude faster than BLAST. *Bioinformatics* 26, 2460–2461. <https://doi.org/10.1093/bioinformatics/btq461>
- Edgar, R.C., Haas, B.J., Clemente, J.C., Quince, C., Knight, R., 2011. UCHIME improves sensitivity and speed of chimera detection. *Bioinformatics* 27, 2194–2200. <https://doi.org/10.1093/bioinformatics/btr381>
- Elder, B.L., Trujillo, I., Blazevic, D.J., 1977. Rapid deoxyribonuclease test with methyl green. *J. Clin. Microbiol.* 6, 312–313.
- Eribe, E.R.K., Olsen, I., 2002. SDS-PAGE of whole-cell proteins and random amplified polymorphic DNA (RAPD) analyses of *Leptotrichia* isolates. *Microb. Ecol. Health Dis.* 14, 193–202. <https://doi.org/10.1080/08910600310002073>
- Ernst, O., Zor, T., 2010. Linearization of the Bradford protein assay. *J. Vis. Exp.* 1–6. <https://doi.org/10.3791/1918>

- Esteban, J., Molleja, A., Cabria, F., Jiménez, M.S., 2003. SDS-PAGE for identification of species belonging to the *Mycobacterium fortuitum* complex. Clin. Microbiol. Infect. 9, 327–331. <https://doi.org/10.1046/j.1469-0691.2003.00542.x>
- Eswari, J.S., Dhagat, S., Sen, R. 2019. Thermophiles for biotech industry. A bioprocess technology perspective. Springer Nature Singapore Pte Ltd. <https://doi.org/10.1007/978-981-32-9919-1>
- Fekraoui, A., Kedaid, F., 2005. Geothermal resources and uses in Algeria : A country update report. Direct. 24–29. ISBN. 1-55798-568-5
- Felsenstein, J., 1985. Confidence limits on phylogenies: an approach using the bootstrap. Evolution 39, 783–791. <https://doi.org/10.1111/j.1558-5646.1985.tb00420.x>
- Finore, I., Gioiello, A., Leone, L., Orlando, P., Romano, I., Nicolaus, B., Poli, A., 2017. *Aeribacillus composti* sp. Nov., a thermophilic bacillus isolated from olive mill pomace compost. Int. J. Syst. Evol. Microbiol. 67, 4830–4835. <https://doi.org/10.1099/ijsem.0.002391>
- Fox, A., Ueda, K., Morgan, S.L. 1990. Analysis of bacterial amino acids. In: Fox A., Morgan, S.L., Larsson, L., Odham, G. Analytical microbiology methods. Springer, Boston, MA. [https://doi.org/10.1007/978-1-4899-3564-9\\_6](https://doi.org/10.1007/978-1-4899-3564-9_6)
- Frazier, W.C., 1926. A method for the detection of changes in gelatin due to bacteria. J. Infect. Dis. 39, 302–309. <https://doi.org/10.1093/infdis/39.4.302>
- Fry, J.C., 2004. Culture-dependent microbiology. In: Bull, A.T. Microbial diversity and bioprospecting. ASM Press. <https://doi.org/10.1128/9781555817770>.
- Garcia Costas, A.M., Liu, Z., Tomsho, L.P., Schuster, S.C., Ward, D.M., Bryant, D.A., 2012. Complete genome of Candidatus *Chloracidobacterium thermophilum*, a chlorophyll-based photoheterotroph belonging to the phylum *Acidobacteria*. Environ. Microbiol. 14, 177–190. <https://doi.org/10.1111/j.1462-2920.2011.02592.x>
- Garrity, G.M., Holt, J.G., 2015. *Chlorobi* phy. nov., in: Bergey's Manual of Systematics of *Archaea* and *Bacteria*. p. 1. <https://doi.org/10.1002/9781118960608.pbm00006>
- Ghilamical, A.M., Budambula, N.L.M., Anami, S.E., Mehari, T., Boga, H.I., 2017. Evaluation of prokaryotic diversity of five hot springs in Eritrea. BMC Microbiol. 17, 1–13. <https://doi.org/10.1186/s12866-017-1113-4>
- Goh, K.M., Gan, H.M., Chan, K.G., Chan, G.F., Shahar, S., Chong, C.S., Kahar, U.M., Chai, K.P., 2014. Analysis of *Anoxybacillus* genomes from the aspects of lifestyle adaptations, prophage diversity, and carbohydrate metabolism. PLoS One 9, e90549. <https://doi.org/10.1371/journal.pone.0090549>
- Gómez, F., 2011. Extreme environment. In: Gargaud, M., Irvine, W.M., Henderson, R.M., Cleaves, J., Pinti, D.L., Quintanilla, J.C., Rouan, D., Spohn, T., Tirard, S., Viso, M. Encyclopedia of astrobiology. Springer, Berlin, Heidelberg. [https://doi.org/10.1007/978-3-642-11274-4\\_566](https://doi.org/10.1007/978-3-642-11274-4_566)
- Gomri, M.A., Khaldi, T.E.M., Kharroub, K., 2018. Analysis of the diversity of aerobic, thermophilic endospore-forming bacteria in two Algerian hot springs using cultural and non-cultural methods. Ann. Microbiol. 68, 915–929. <https://doi.org/10.1007/s13213-018-1401-8>
- Goodfellow, M., Jones, A.L., 2015a. *Thermoactinomyces*, in: Bergey's Manual of Systematics of *Archaea* and *Bacteria*. pp. 1–5. <https://doi.org/10.1002/9781118960608.gbm00575>
- Goodfellow, M., Jones, A.L., 2015b. *Laceyella*, in: Bergey's Manual of Systematics of *Archaea* and *Bacteria*. pp.1–4. <https://doi.org/10.1002/9781118960608.gbm00570>

- Goodfellow, M., Jones, A.L., 2015c. *Thermoactinomycetaceae*, in: Bergey's Manual of Systematics of Archaea and Bacteria. pp. 1–18. <https://doi.org/10.1002/9781118960608.fbm00119>
- Gopinath, S.C.B., Anbu, P., Hilda, A., 2005. Extracellular enzymatic activity profiles in fungi isolated from oil-rich environments. *Mycoscience*. 46, 119–126. <https://doi.org/10.1007/s10267-004-0221-9>
- Gregersen, T., 1978. Method for the distinction of Gram-negative from Gram-positive bacteria. *Eur. J. Appl. Microbiol.* 5, 123–127. <https://doi.org/10.1007/BF01385437>
- Gugliandolo, C., Lentini, V., Maugeri, T.L., 2015. Changes in prokaryotic community composition accompanying a pronounced temperature shift of a shallow marine thermal brine pool (Panarea Island, Italy). *Extremophiles*. 547–559. <https://doi.org/10.1007/s00792-015-0737-2>
- Hach, 2015. Hardness, total-titration method with EDTA. Method 8213. DOC316.53.01176. Hach Company/Hach Lange GmbH. 8<sup>th</sup> edition.
- Hall, T.A., 1999. BioEdit: a user-friendly biological sequence alignment editor and analysis program for Windows 95/98/NT. *Nucleic Acids Symp Ser.* 41, 95–98. [https://doi.org/10.14601/Phytopathol\\_Mediterr-14998u1.29](https://doi.org/10.14601/Phytopathol_Mediterr-14998u1.29)
- Hamzah, Z., Rani, N.L.A., Saat, A., Wood, A.K., 2013. Determination of hot springs physico-chemical water quality potentially use for balneotherapy. *Malaysian J. Anal. Sci.* 17, 436–444.
- Han, H., Ling, Z., Khan, A., Virk, A.K., Kulshrestha, S., Li, X., 2019. Improvements of thermophilic enzymes: From genetic modifications to applications. *Bioresour. Technol.* <https://doi.org/10.1016/j.biortech.2019.01.087>
- Hari, R., 2018. Next-generation sequencing data analysis. *Encyclopedia of bioinformatics and computational biology*. Elsevier Ltd. <https://doi.org/10.1016/B978-0-12-809633-8.20093-9>
- Harnvoravongchai, P., Singwisut, R., Ounjai, P., Aroonual, A., Kosiyachinda, P., Janvilisri, T., Chankhamhaengdecha, S., 2020. Isolation and characterization of thermophilic cellulose and hemicellulose degrading bacterium, *Thermoanaerobacterium* sp. R63 from tropical dry deciduous forest soil. *PLoS One*. 15, 1–16. <https://doi.org/10.1371/journal.pone.0236518>
- Haynes, W. M., 2009. *CRC handbook of chemistry and physics: A ready-reference book of chemical and physical data*. Boca Raton: CRC Press.
- Heizer, W.D., Sandler, R.S., Seal, E., Murray, S.C., Busby, M.G., Schliebe, B.G., Pusek, S.N., 1997. Intestinal effects of sulfate in drinking water on normal human subjects. *Dig. Dis. Sci.* 42, 1055–1061. <https://doi.org/10.1023/A:1018801522760>
- Holden, J.H., 2009. Extremophiles: Hot environments. In: Schaechter, M. *Encyclopedia of microbiology*, 3<sup>rd</sup> edition. Academic Press. pp. 127-146.
- Hou, W., Wang, S., Dong, H., Jiang, H., Briggs, B.R., Peacock, J.P., Huang, Q., Huang, L., Wu, G., Zhi, X., Li, W., Dodsworth, J.A., Hedlund, B.P., Zhang, C., Hartnett, H.E., Dijkstra, P., Hungate, B.A., 2013. A comprehensive census of microbial diversity in hot springs of Tengchong, Yunnan Province, China using 16S rRNA gene pyrosequencing. *PLoS One* 8. <https://doi.org/10.1371/journal.pone.0053350>
- Hu, E., Lan, X., Liu, Z., Gao, J., Niu, D., 2021. Positive correlation between bacterial GC content and growth temperature. *bioRxiv*. 1–20. <https://doi.org/10.1101/2021.04.27.441598>

- Huang, Q., Jiang, H., Briggs, B.R., Wang, S., Hou, W., Li, G., Wu, G., Solis, R., Arcilla, C.A., Abrajano, T., Dong, H., 2013. Archaeal and bacterial diversity in acidic to circumneutral hot springs in the Philippines. *FEMS Microbiol. Ecol.* 85, 452–464. <https://doi.org/10.1111/1574-6941.12134>
- Huber, R., Stetter, K.O., 2015. *Pyrobaculum*, in: *Bergey's Manual of Systematics of Archaea and Bacteria*. pp. 1–6. <https://doi.org/10.1002/9781118960608.gbm00406>
- Iino, T., Mori, K., Uchino, Y., Nakagawa, T., Harayama, S., Suzuki, K.I., 2010. *Ignavibacterium album* gen. nov., sp. nov., a moderately thermophilic anaerobic bacterium isolated from microbial mats at a terrestrial hot spring and proposal of *Ignavibacteria classis* nov., for a novel lineage at the periphery of green sulfur bacteria. *Int. J. Syst. Evol. Microbiol.* 60, 1376–1382. <https://doi.org/10.1099/ijms.0.012484-0>
- Ilyas, S., Lee, J., Kim, B., 2014. Bioremoval of heavy metals from recycling industry electronic waste by a consortium of moderate thermophiles: Process development and optimization. *J. Clean. Prod.* 70, 194–202. <https://doi.org/10.1016/j.jclepro.2014.02.019>
- Imhoff, J.F., 2015. *Rhodobacter*, in: *Bergey's Manual of Systematics of Archaea and Bacteria*. pp. 1–12. <https://doi.org/10.1002/9781118960608.gbm00862>
- Inan, K., Bektas, Y., Canakci, S., Belduz, A.O., 2011a. Use of rpoB sequences and rep-PCR for phylogenetic study of *Anoxybacillus* species. *J. Microbiol.* 49, 782–790. <https://doi.org/10.1007/s12275-011-1136-8>
- Inan, K., Çanakçı, S., Beldüz, A.O., 2011b. Isolation and characterization of xylanolytic new strains of *Anoxybacillus* from some hot springs in Turkey. *Turkish J. Biol.* 35, 529–542. <https://doi.org/10.3906/biy-1003-75>
- Inan, K., Ozer, A., Guler, H.I., Belduz, A.O., Canakci, S., 2016. *Brevibacillus gelatini* sp. nov., isolated from a hot spring. *Int. J. Syst. Evol. Microbiol.* 66, 712–718. <https://doi.org/10.1099/ijsem.0.000780>
- Inskip, W.P., Jay, Z.J., Tringe, S.G., Herrgård, M.J., Rusch, D.B., 2013. The YNP metagenome project: Environmental parameters responsible for microbial distribution in the Yellowstone geothermal ecosystem. *Front. Microbiol.* 4, 67. <https://doi.org/10.3389/fmicb.2013.00067>
- Janda, J.M., Abbott, S.L., 2007. 16S rRNA gene sequencing for bacterial identification in the diagnostic laboratory: Pluses, perils, and pitfalls. *J. Clin. Microbiol.* <https://doi.org/10.1128/JCM.01228-07>
- Jardine, J.L., Stoychev, S., Mavumengwana, V., Ubomba-Jaswa, E., 2018. Screening of potential bioremediation enzymes from hot spring bacteria using conventional plate assays and liquid chromatography-tandem mass spectrometry (Lc-Ms/Ms). *J. Environ. Manage.* 223, 787–796. <https://doi.org/10.1016/j.jenvman.2018.06.089>
- Johnson, J., Jain, K., Madamwar, D., 2017. Functional metagenomics: Exploring nature's gold mine 27–43. <https://doi.org/10.1016/B978-0-444-63667-6.00002-X>
- Joshi, N., Sharma, M., Singh, S.P., 2020. Characterization of a novel xylanase from an extreme temperature hot spring metagenome for xylooligosaccharide production. *Appl. Microbiol. Biotechnol.* 104, 4889–4901. <https://doi.org/10.1007/s00253-020-10562-7>
- Juers, D. H., Matthews, B. W. Huber, R.E., 2012. LacZ  $\beta$ -galactosidase: Structure and function of an enzyme of historical and molecular biological importance. *Protein Sci.* 21(12), 1792–1807. Doi:10.1002/pro.2165.
- Julin, D.A., 2018. Blue/white selection. In: Wells, R.D., Bond, J.S., Klinman, J., Masters, B.S.S. *Molecular life sciences*. Springer, New York, NY. <https://doi.org/10.1007/978-1-4614->

- Kambura, A.K., Mwirichia, R.K., Kasili, R.W., Karanja, E.N., Makonde, H.M., Boga, H.I., 2016. *Bacteria* and *Archaea* diversity within the hot springs of Lake Magadi and Little Magadi in Kenya. *BMC Microbiol.* 16, 1–12. <https://doi.org/10.1186/s12866-016-0748-x>
- Kamli, M.R., Alzahrani, N.A.Y., Hajrah, N.H., Sabir, J.S.M., Malik, A., 2021. Genome-driven discovery of enzymes with industrial implications from the genus *Aneurinibacillus*. *Microorganisms* 9, 1–24. <https://doi.org/10.3390/microorganisms9030499>
- Kämpfer, P., 1995. Differentiation of *Brevibacterium* species by electrophoretic protein patterns. *Syst. Appl. Microbiol.* 17, 533–535. [https://doi.org/10.1016/S0723-2020\(11\)80073-1](https://doi.org/10.1016/S0723-2020(11)80073-1)
- Kämpfer, P., Glaeser, S.P., 2012. Prokaryotic taxonomy in the sequencing era : The polyphasic approach revisited. *Environ. Microbiol.* 14(2), 291–317. <https://doi.org/10.1111/j.1462-2920.2011.02615.x>
- Kasana, R.C., Salwan, R., Dhar, H., Dutt, S., Gulati, A., 2008. A rapid and easy method for the detection of microbial cellulases on agar plates using Gram's iodine. *Curr. Microbiol.* 57, 503–507. <https://doi.org/10.1007/s00284-008-9276-8>
- Kecha, M., Benallaoua, S., Touzel, J.P., Bonaly, R., Duchiron, F., 2007. Biochemical and phylogenetic characterization of a novel terrestrial hyperthermophilic archaeon pertaining to the genus *Pyrococcus* from an Algerian hydrothermal hot spring. *Extremophiles.* 11, 65–73. <https://doi.org/10.1007/s00792-006-0010-9>
- Kedaid, F.Z., 2007. Database on the geothermal resources of Algeria. *Geothermics.* 36, 265–275. <https://doi.org/10.1016/j.geothermics.2007.02.002>
- Kedaid, F.Z., 2006. Développement de la base de données géothermiques de l'Algérie par un système d'information géographique. *Rev. des Energies Renouvelables.* 9, 253–258.
- Khan, I.U., Habib, N., Xiao, M., Devi, A.M., Habib, M., Hejazi, M.S., Salam, N., Zhi, X.Y., Li, W.J., 2018. *Anoxybacillus sediminis* sp. nov., a novel moderately thermophilic bacterium isolated from a hot spring. *Antonie van Leeuwenhoek, Int. J. Gen. Mol. Microbiol.* 111, 2275–2282. <https://doi.org/10.1007/s10482-018-1118-5>
- Khelil, O., Cheba, B., 2014. Thermophilic cellulolytic microorganisms from Western Algerian sources: Promising isolates for cellulosic biomass recycling. *Procedia Technol.* 12, 519–528. <https://doi.org/10.1016/j.protcy.2013.12.524>
- Kikani, B.A., Sharma, A.K., Singh, S.P., 2015. Culture-dependent diversity and phylogeny of thermophilic bacilli from a natural hot spring reservoir in the Gir Forest, Gujarat (India). *Microbiol.* 84, 687–700. <https://doi.org/10.1134/S0026261715050124>
- Kikani, B.A., Sharma, A.K. Singh S.P., 2017. Metagenomic and culture-dependent analysis of the bacterial diversity of a hot spring reservoir as a function of the seasonal variation. *Int. J. Environ. Res.* 11, 25–38. <https://doi.org/10.1007/s41742-017-0003-9>
- Kim, M., Chun, J., 2014. 16S rRNA gene-based identification of bacteria and archaea using the EzTaxon server (Chapter 4).41, 61–74. In: *Methods in Microbiology*. 1<sup>st</sup> edition. Elsevier Ltd. <https://doi.org/10.1016/bs.mim.2014.08.001>
- Kim, M., Oh, H.S., Park, S.C., Chun, J., 2014. Towards a taxonomic coherence between average nucleotide identity and 16S rRNA gene sequence similarity for species demarcation of prokaryotes. *Int. J. Syst. Evol. Microbiol.* 64, 346–351. <https://doi.org/10.1099/ijs.0.059774-0>
- Kim, T.W., Kim, Y.H., Kim, S.E., Lee, J.H., Park, C.S., Kim, H.Y., 2010. Identification and distribution of *Bacillus* species in Doenjang by whole-cell protein patterns and 16S rRNA

- gene sequence analysis. *J. Microbiol. Biotechnol.* 20, 1210–1214. <https://doi.org/10.4014/jmb.1002.02008>
- Kimura, M., 1980. A simple method for estimating evolutionary rates of base substitutions through comparative studies of nucleotide sequences. *J. Mol. Evol.* 16(2), 111–20. <https://doi: 10.1007/BF01731581>.
- Kirk, G., 2004. *The biogeochemistry of submerged soils*. Chichester, UK: John Wiley & Sons, Ltd. (hardcover). pp. 304
- Kitouni, M., Boudemagh, A., Oulmi, L., Reghioia, S., Boughachiche, F., Zerizer, H., Hamdiken, H., Couble, A., Mouniee, D., Boulahrouf, A., Boiron, P., 2005. Isolation of *Actinomycetes* producing bioactive substances from water, soil and tree bark samples of the northeast of Algeria. *J. Mycol. Med.* 15, 45–51. <https://doi.org/10.1016/j.mycmed.2004.12.005>
- Knapik, K., Becerra, M., González-Siso, M.I., 2019. Microbial diversity analysis and screening for novel xylanase enzymes from the sediment of the Lobios Hot Spring in Spain. *Sci. Rep.* 9, 1–12. <https://doi.org/10.1038/s41598-019-47637-z>
- Komatina, M.M., 2004. Geological factors: Environment of life, natural environment, and geological environment In: Komatina, M.M. *Medical geology: Effects of geological environments on human health*. Volume 2. 1<sup>st</sup> edition. Elsevier Science. pp. 39-235.
- Kreil, D.P., Ouzounis, C.A., 2001. Identification of thermophilic species by the amino acid compositions deduced from their genomes. *Nucleic Acids Res.* 29, 1608–15. <https://doi.org/10.1093/nar/29.7.1608>
- Kristjansson, J.K., 1991. *Thermophilic bacteria*. 1<sup>st</sup> edition. CRS Press. ISBN 9780849352393
- Kuhad, R.C., Gupta, R., Singh, A., 2011. Microbial cellulases and their industrial applications. *Enzyme Res.* 2011. <https://doi.org/10.4061/2011/280696>
- Kuisene, N., Emantene, R., Valiunas, D., Chitavichus, D., 2002. Characterization of thermophilic spore-forming bacteria from a geothermal spring in Lithuania based on 16S rDNA and 16S-23S rDNA intergenic spacers analyses. *Mikrobiologija.* 71, 824–828.
- Kumar, M., Yadav, A.N., Tiwari, R., Prasanna, R., Saxena, A.K., 2014. Deciphering the diversity of culturable thermotolerant bacteria from Manikaran hot springs. *Ann. Microbiol.* 64, 741–751. <https://doi.org/10.1007/s13213-013-0709-7>
- Kumar Neelam, D., Agrawal, A., Kumar Tomer, A., K. Dadheech, P., 2019. Characterization, phylogenetic analysis, and potential applications of heterotrophic bacteria inhabit sand dunes of Thar Desert, India. *J. Pure Appl. Microbiol.* 12, 1887–1898. <https://doi.org/10.22207/jpam.12.4.24>
- Kumar, S., Dangi, A.K., Shukla, P., Baishya, D., Khare, S.K., 2019. Thermozyms: Adaptive strategies and tools for their biotechnological applications. *Bioresour. Technol.* 278, 372–382. <https://doi.org/10.1016/j.biortech.2019.01.088>
- Kumar, V., and Satyanarayana, T., 2013. Thermoalkaliphilic microbes. In: Seckbach, J., Oren, A., Stan-Lotter, H. *Polyextremophiles: life under multiple forms of stress*. Springer, Dordrecht. <https://doi.org/10.1007/978-94-007-6488-0>.
- Laemmli, U.K., 1970. Cleavage of structural proteins during the assembly of the head of bacteriophage T4. *Nature.* 227, 680–685. <https://doi.org/10.1038/227680a0>
- Lau, M.C.Y., Aitchison, J.C., Pointing, S.B., 2009. Bacterial community composition in thermophilic microbial mats from five hot springs in central Tibet. *Extremophiles.* 13, 139–149. <https://doi.org/10.1007/s00792-008-0205-3>

- Lavrentyeva, E. V., Radnagurueva, A.A., Barkhutova, D.D., Belkova, N.L., Zaitseva, S. V., Namsaraev, Z.B., Gorlenko, V.M., Namsaraev, B.B., 2018. Bacterial diversity and functional activity of microbial communities in hot springs of the Baikal Rift Zone. *Microbiology*. 87, 272–281. <https://doi.org/10.1134/S0026261718020078>
- Law, J.W.-F., Letchumanan, V., Tan, L.T.-H., Ser, H.-L., Goh, B.-H., Lee, L.-H., 2020. The rising of “Modern Actinobacteria” era. *Prog. Microbes Mol. Biol.* 3, 1–6. <https://doi.org/10.36877/pmmb.a0000064>
- Li, L., Ma, Z., 2019. Global microbiome diversity scaling in hot springs with DAR (Diversity-area relationship) profiles. *Front. Microbiol.* 10. <https://doi.org/10.3389/fmicb.2019.00118>
- Li, Y., Zhang, Jiejie, Zhang, Jianqiang, Xu, W., Mou, Z., 2019. Microbial community structure in the sediments and its relation to environmental factors in eutrophicated Sancha Lake. *Int. J. Environ. Res. Public Health*. 16, 1931. <https://doi.org/10.3390/ijerph16111931>
- Liang, J., Kang, D., Wang, Y., Yu, Y., Fan, J., Takashi, E., 2015. Carbonate ion-enriched hot spring water promotes skin wound healing in nude rats. *PLoS One*. 10, e0117106. <https://doi.org/10.1371/journal.pone.0117106>
- Lin, C.C., Casida, L.E., 1984. Gelrite as a gelling agent in media for the growth of thermophilic microorganisms. *Appl. Environ. Microbiol.* 47, 427–429. <https://doi.org/10.1128/aem.47.2.427-429.1984>
- Liu, B., Li, H., Wu, S., Zhang, X., Xie, L., 2006. A simple and rapid method for the differentiation and identification of thermophilic bacteria. *Can. J. Microbiol.* 52, 753–758. <https://doi.org/10.1139/w06-036>
- Liu, L., Salam, N., Jiao, J.-Y., Jiang, H.-C., Zhou, E.-M., Yin, Y.-R., Ming, H., Li, W.J., 2016. Diversity of culturable thermophilic *Actinobacteria* in hot springs in Tengchong, China and studies of their biosynthetic gene profiles. *Microb. Ecol.* 72, 150–162. <https://doi.org/10.1007/s00248-016-0756-2>
- Liu, Z., Desantis, T.Z., Andersen, G.L., Knight, R., 2008. Accurate taxonomy assignments from 16S rRNA sequences produced by highly parallel pyrosequencers. *Nucleic Acids Res.* 36, 1–11. <https://doi.org/10.1093/nar/gkn491>
- Logan, N.A., Lebbe, L., Hoste, B., Goris, J., Forsyth, G., Heyndrickx, M., Murray, B.L., Syme, N., Wynn-Williams, D.D., De Vos, P., 2000. Aerobic endospore-forming bacteria from geothermal environments in Northern Victoria Land, Antarctica, and Candlemas Island, South Sandwich Archipelago, with the proposal of *Bacillus fumarioli* sp. nov. *Int. J. Syst. Evol. Microbiol.* 50, 1741–1753. <https://doi.org/10.1099/00207713-50-5-1741>
- Logan, N.A., Vos, P. D., 2015. *Aneurinibacillus*, in: *Bergey’s Manual of Systematics of Archaea and Bacteria*. pp. 1–13. <https://doi.org/10.1002/9781118960608.gbm00549>
- Logan, N.A., Vos, P. De, Dinsdale, A., 2015. *Geobacillus*, in: *Bergey’s Manual of Systematics of Archaea and Bacteria*. pp. 1–26. <https://doi.org/10.1002/9781118960608.gbm00533>
- López-López, O., Cerdán, M., González-Siso, M., 2013. Hot spring metagenomics. *Life*. 3, 308–320. <https://doi.org/10.3390/life3020308>
- López, P., Pérez-Rodríguez, I., Estrany, F., Devesa, R., 2017. Effects of sulfate and nitrate on the taste of water: A study with a trained panel. *J. Water Supply Res. Technol. - AQUA* 66, 598–605. <https://doi.org/10.2166/aqua.2017.183>
- LPSN, 2021. List of prokaryotic names with standing in nomenclature moves to the DSMZ. *Int. J. Syst. Evol.* 70, 5607-5612. <https://doi.org/10.1099/ijsem.0.004332>.
- Luo, X., Xiang, X., Huang, G., Song, X., Wang, P., Fu, K., 2019. Bacterial abundance and

- physicochemical characteristics of water and sediment associated with hydroelectric dam on the Lancang River China. *Int. J. Environ. Res. Public Health* 16, 2031. <https://doi.org/10.3390/ijerph16112031>
- Mahajan, G.B., Balachandran, L., 2017. Sources of antibiotics: Hot springs. *Biochem. Pharmacol.* 134, 35–41. <https://doi.org/10.1016/j.bcp.2016.11.021>
- Mahala, S.C., 2019. Geochemistry of thermal water. In: Mahala, S.C. *Geology, Chemistry and genesis of thermal springs of Odisha, India*. Springer. <https://doi.org/10.1007/978-3-319-90002-5>.
- Mangrola, A.V., Dudhagara, P., Koringa, P., Joshi, C.G., Patel, R.K., 2015. Shotgun metagenomic sequencing-based microbial diversity assessment of Lasundra hot spring, India. *Genomics Data.* 4, 73–75. <https://doi.org/10.1016/j.gdata.2015.03.005>
- Marini, A., Talbi, M., 2009. *Desertification and risk analysis using high and medium resolution satellite data*. 1<sup>st</sup> edition. Springer. <https://doi.org/10.1007/978-1-4020-8937-4>
- Marteinsson, V.T., Birrien, J.L., Jeanthon, C., Prieur, D., 1996. Numerical taxonomic study of thermophilic *Bacillus* isolated from three geographically separated deep-sea hydrothermal vents. *FEMS Microbiol. Ecol.* 21, 255–266. [https://doi.org/10.1016/S0168-6496\(96\)00061-X](https://doi.org/10.1016/S0168-6496(96)00061-X)
- Martiny, J.B.H., Eisen, J.A., Penn, K., Allison, S.D., Horner-Devine, M.C., 2011. Drivers of bacterial  $\beta$ -diversity depend on spatial scale. *Proc. Natl. Acad. Sci. U.S.A.* 108, 7850–7854. <https://doi.org/10.1073/pnas.1016308108>
- Masaki, Y., Tsutsumi, K., Hirano, S., Okibe, N., 2016. Microbial community profiling of the Chinoike Jigoku (“Blood Pond Hell”) hot spring in Beppu, Japan: isolation and characterization of Fe ( III )- reducing *Sulfolobus* sp. strain GA1. *Res. Microbiol.* 1–9. <https://doi.org/10.1016/j.resmic.2016.04.011>
- Matlock, B., 2015. Assessment of nucleic acid purity. Technical note 52646. Thermo Fisher Scientific. <https://assets.thermofisher.com>
- Maus, D., Heinz, J., Schirmack, J., Airo, A., Kounaves, S.P., Wagner, D., Schulze-makuch, D., 2020. Methanogenic *Archaea* can produce methane in Deliquescence- Driven Mars analog environments. *Sci. Rep.* 10 (6), 1–7. <https://doi.org/10.1038/s41598-019-56267-4>
- Mehetre, G.T., Dastager, S.G., Dharne, M.S., 2019. Biodegradation of mixed polycyclic aromatic hydrocarbons by pure and mixed cultures of biosurfactant producing thermophilic and thermo-tolerant bacteria. *Sci. Total Environ.* 679, 52–60. <https://doi.org/10.1016/j.scitotenv.2019.04.376>
- Mehetre, G.T., Paranjpe, A.S., Dastager, S.G., Dharne, M.S., 2016. Complete metagenome sequencing-based bacterial diversity and functional insights from basaltic hot spring of Unkeshwar, Maharashtra, India. *Genomics Data.* 7, 140–143. <https://doi.org/10.1016/j.gdata.2015.12.031>
- Mehta, D., Satyanarayana, T., 2013. Diversity of hot environments and thermophilic microbes. In: Satyanarayana, T., Littlechild, J., and Kawarabayasi, Y. *Thermophilic microbes in environmental and industrial biotechnology*. Springer International Publishing, pp. 3-60.
- Mehta, R., Singhal, P., Singh, H., Damle, D., Sharma, A.K., 2016. Insight into thermophiles and their wide-spectrum applications. *3 Biotech.* 6, 1–9. <https://doi.org/10.1007/s13205-016-0368-z>
- Meija, J., Michałowska-Kaczmarczyk, A.M., Michałowski, T., 2016. Mohr’s method challenge. *Anal. Bioanal. Chem.* 408, 1721–1722. <https://doi.org/10.1007/s00216-015-9273-2>

- Meintanis, C., Chalkou, K.I., Kormas, K.A., Lymperopoulou, D.S., Katsifas, E.A., Hatzinikolaou, D.G., Karagouni, A.D., 2008. Application of rpoB sequence similarity analysis, REP-PCR and BOX-PCR for the differentiation of species within the genus *Geobacillus*. *Lett. Appl. Microbiol.* 46, 395–401. <https://doi.org/10.1111/j.1472-765X.2008.02328.x>
- Menasria, T., 2020. Biodiversité microbienne dans les milieux extrêmes fortement salés du Nord-Est Algérien. Ph.D.Thesis in Applied microbiology, University of Batna 2. Algeria. pp. 183
- Menasria, T., Monteoliva-Sánchez, M., Benammar, L., Benhadj, M., Ayachi, A., Hacène, H., Gonzalez-Paredes, A., Aguilera, M., 2019. Culturable halophilic bacteria inhabiting Algerian saline ecosystems: A source of promising features and potentialities. *World J. Microbiol. Biotechnol.* 35, 132. <https://doi.org/10.1007/s11274-019-2705-y>
- Merino, N., Aronson, H.S., Bojanova, D.P., Feyhl-Buska, J., Wong, M.L., Zhang, S., Giovannelli, D., 2019. Living at the extremes: Extremophiles and the limits of life in a planetary context. *Front. Microbiol.* 10, 780. <https://doi.org/10.3389/fmicb.2019.00780>
- Merkel, A.Y., Pimenov, N. V., Rusanov, I.I., Slobodkin, A.I., Slobodkina, G.B., Tarnovetckii, I.Y., Frolov, E.N., Dubin, A. V., Perevalova, A.A., Bonch-Osmolovskaya, E.A., 2017. Microbial diversity and autotrophic activity in Kamchatka hot springs. *Extremophiles.* 21, 307–317. <https://doi.org/10.1007/s00792-016-0903-1>
- Miñana-Galbis, D., Pinzón, D.L., Lorén, J.G., Manresa, À., Oliart-Ros, R.M., 2010. Reclassification of *Geobacillus pallidus* (Scholz et al. 1988) Banat et al. 2004 as *Aeribacillus pallidus* gen. nov., comb. nov. *Int. J. Syst. Evol. Microbiol.* <https://doi.org/10.1099/ijms.0.003699-0>
- Ming, H., Ji, W.L., Li, S., Zhao, Z.L., Zhang, L.Y., Meng, X.L., Zhou, E.M., Nie, G.X., Li, W.J., 2017. *Laceyella thermophila* sp. nov., a thermophilic bacterium isolated from a hot spring. *Int. J. Syst. Evol. Microbiol.* 67, 2953–2958. <https://doi.org/10.1099/ijsem.0.002057>
- Mirete, S., de Figueras, C.G., González-Pastor, J.E., 2011. Diversity of *Archaea* in Icelandic hot springs based on 16S rRNA and chaperonin genes. *FEMS Microbiol. Ecol.* 77, 165–175. <https://doi.org/10.1111/j.1574-6941.2011.01095.x>
- Mohamad, O.A.A., 2018. Extremophiles in Eurasian ecosystems: ecology, diversity, and applications, microorganisms for sustainability. Springer, Singapore. <https://doi.org/10.1007/978-981-13-0329-6>
- Mokrane, S., Bouras, N., Meklat, A., Lahoum, A., Zitouni, A., Verheecke, C., Mathieu, F., Schumann, P., Spröer, C., Sabaou, N., Klenk, H.P., 2016. *Thermoactinomyces khenchelensis* sp. nov., a filamentous bacterium isolated from soil sediment of a terrestrial hot spring. *Antonie van Leeuwenhoek, Int. J. Gen. Mol. Microbiol.* 109, 311–317. <https://doi.org/10.1007/s10482-015-0634-9>
- Morris, E.K., Caruso, T., Buscot, F., Fischer, M., Hancock, C., Maier, T.S., Meiners, T., Müller, C., Obermaier, E., Prati, D., Socher, S.A., Sonnemann, I., Wäschke, N., Wubet, T., Wurst, S., Rillig, M.C., 2014. Choosing and using diversity indices: Insights for ecological applications from the German biodiversity exploratories. *Ecol. Evol.* 4, 3514–3524. <https://doi.org/10.1002/ece3.1155>
- MTATF, 2015. Plan de développement du thermalisme. Algerian Ministry of Tourism, Crafts and Family Work. [http://www.mtatf.gov.dz/?page\\_id=477](http://www.mtatf.gov.dz/?page_id=477). Consulted in 17/06/2020.
- Nabi, N., Chaouachi, M., Zellama, M.S., Ben Hafsa, A., Mrabet, B., Saïd, K., Fathia, H.S., 2016. A new QRT-PCR assay designed for the differentiation between elements provided

- from *Agrobacterium* sp. in GMOs plant events and natural *Agrobacterium* sp. bacteria. Food Chem. 196, 58–65. <https://doi.org/10.1016/j.foodchem.2015.09.015>
- Najar, I.N., Sherpa, M.T., Das, S., Verma, K., Dubey, V.K., Thakur, N., 2018a. *Geobacillus yumthangensis* sp. nov., a thermophilic bacterium isolated from a Northeast Indian hot spring. Int. J. Syst. Evol. Microbiol. 68, 3430–3434. <https://doi.org/10.1099/ijsem.0.003002>
- Najar, I.N., Sherpa, M.T., Das, Sayak, Das, Saurav, Thakur, N., 2018b. Microbial ecology of two hot springs of Sikkim: Predominate population and geochemistry. Sci. Total Environ. 637–638, 730–745. <https://doi.org/10.1016/j.scitotenv.2018.05.037>
- Narayan, V. V., Hatha, M.A., Morgan, H.W., Rao, D., 2008. Isolation and characterization of aerobic thermophilic bacteria from the Savusavu hot springs in Fiji. Microbe. Microbes Environ. 23, 350–352. <https://doi.org/10.1264/jsme2.ME08105>
- Narsing Rao, M.P., Liu, L., Jiao, J.Y., Xiao, M., Li, W.J., 2018. Hot springs of India: Occurrence and microbial diversity. 29–55. [https://doi.org/10.1007/978-981-13-0329-6\\_2](https://doi.org/10.1007/978-981-13-0329-6_2)
- Nguyen, K.T., Nguyen, N.L., Tung, N. Van, Nguyen, H.H., Milhim, M., Le, T.T.X., Lai, T.H.N., Phan, T.T.M., Bernhardt, R., 2020. A novel thermostable cytochrome p450 from sequence-based metagenomics of Binh Chau hot spring as a promising catalyst for testosterone conversion. Catalysts. 10, 1–17. <https://doi.org/10.3390/catal10091083>
- Nicholson, W.L., Munakata, N., Horneck, G., Melosh, H.J., Setlow, P., 2000. Resistance of *Bacillus* endospores to extreme terrestrial and extraterrestrial environments. Microbiol. Mol. Biol. Rev. 64, 548–572. <https://doi.org/10.1128/membr.64.3.548-572.2000>
- Niehaus, F., Bertoldo, C., Kähler, M., Antranikian, G., 1999. Extremophiles as a source of novel enzymes for industrial application. Appl. Microbiol. Biotechnol. <https://doi.org/10.1007/s002530051456>
- Nobre, A.L., Costa, M.S., Biology, C., 2018. *Thermus*, in: Bergey's Manual of Systematics of *Archaea* and *Bacteria*. pp. 1–39. <https://doi.org/10.1002/9781118960608.gbm00477.pub2>
- Nonomura, H., Ohara, Y. 1971. Distribution of *Actinomycetes* in soil. X. New genus and species of monosporic actinomycetes in soil. Journal of Fermentation Technology. 49, 895-903
- Norbert, S., Tanot, U., Yusry, M., Dzulkafli, M.A., 2019. Physico-chemical characterization and potential health benefit of the Hulu Langat hot spring in Selangor, Malaysia. Sains Malaysiana. 48, 2451–2462. <https://doi.org/10.17576/jsm-2019-4811-15>
- Oshima, T., Imahori, K., 1974. Description of *Thermus thermophilus* (Yoshida and Oshima) comb. nov., a nonsporulating thermophilic bacterium from a Japanese thermal Spa. Int. J. Syst. Bacteriol. 24, 102–112. <https://doi.org/10.1099/00207713-24-1-102>
- Ouali, S., 2015. Contribution à l'étude de quelques réservoirs géothermiques en Algérie. Ph.D. Thesis in Geology, University of Houari Boumediene USTHB, Algeria. pp. 196
- Ovando-Chacon, S.L., Tacias-Pascacio, V.G., Ovando-Chacon, G.E., Rosales-Quintero, A., Rodriguez-Leon, A., Ruiz-Valdiviezo, V.M., Servin-Martinez, A., 2020. Characterization of thermophilic microorganisms in the geothermal water flow of El Chichón Volcano Crater Lake. Water. 12 (8), 2172. <https://doi.org/10.3390/W12082172>
- Overmann, J., Abt, B., Sikorski, J., 2017. Present and future of culturing bacteria. Annu. Rev. Microbiol. 71, 711–730. <https://doi.org/10.1146/annurev-micro-090816-093449>
- Özdemir, S., Kılınç, E., Poli, A., Nicolaus, B., 2013. Biosorption of heavy metals (Cd<sup>2+</sup>, Cu<sup>2+</sup>, Co<sup>2+</sup>, and Mn<sup>2+</sup>) by thermophilic bacteria, *Geobacillus thermantarcticus* and *Anoxybacillus amylolyticus*: Equilibrium and kinetic studies. Bioremediat. J. 17, 86–96. <https://doi.org/10.1080/10889868.2012.751961>

- Pala, C., Molari, M., Nizzoli, D., Bartoli, M., Viaroli, P., Manini, E., 2018. Environmental drivers controlling bacterial and archaeal abundance in the sediments of a Mediterranean Lagoon ecosystem. *Curr. Microbiol.* 75, 1147–1155. <https://doi.org/10.1007/s00284-018-1503-3>
- Panda, A.K., Bisht, S.S., De Mandal, S., Kumar, N.S., 2018. Microbial diversity of thermophiles through the lens of next-generation sequencing: Microbial diversity in the genomic era. pp. 217-226. Elsevier Inc. <https://doi.org/10.1016/b978-0-12-814849-5.00013-7>
- Pati, A., Sikorski, J., Nolan, M., Lapidus, A., Copeland, A., Glavina Del Rio, T., Lucas, S., Chen, F., Tice, H., Pitluck, S., Cheng, J.F., Chertkov, O., Brettin, T., Han, C., Detter, J.C., Kuske, C., Bruce, D., Goodwin, L., Chain, P., D'haeseleer, P., Chen, A., Palaniappan, K., Ivanova, N., Mavromatis, K., Mikhailova, N., Rohde, M., Tindall, B.J., Göker, M., Bristow, J., Eisen, J.A., Markowitz, V., Hugenholtz, P., Kyrpides, N.C., Klenk, H.P., 2009. Complete genome sequence of *Saccharomonospora viridis* type strain (P101 T). *Stand. Genomic Sci.* 1, 141–149. <https://doi.org/10.4056/sigs.20263>
- Pembroke, J.T., Ryan, M.P., 2020. Cyanobacterial biofuel production: Current development, challenges and future needs. In: Yadav, A.N., Rastegari, A.A., Yadav, N., Gaur, R. *Biofuels Production – sustainability and advances in microbial bioresources. Biofuel and Biorefinery Technologies.* volume 11. Springer, Cham. [https://doi.org/10.1007/978-3-030-53933-7\\_3](https://doi.org/10.1007/978-3-030-53933-7_3)
- Podosokorskaya, O.A., Kadnikov, V. V., Gavrilov, S.N., Mardanov, A. V., Merkel, A.Y., Karnachuk, O. V., Ravin, N. V., Bonch-Osmolovskaya, E.A., Kublanov, I. V., 2013. Characterization of *Melioribacter roseus* gen. nov., sp. nov., a novel facultatively anaerobic thermophilic cellulolytic bacterium from the class *Ignavibacteria*, and a proposal of a novel bacterial phylum *Ignavibacteriae*. *Environ. Microbiol.* 15, 1759–1771. <https://doi.org/10.1111/1462-2920.12067>
- Power, J.F., Carere, C.R., Lee, C.K., Evans, D.W., Button, M., White, D., Climo, M.D., Hinze, A.M., Morgan, X.C., McDonald, I.R., Cary, S.C., Stott, M.B., 2018. Microbial biogeography of 1,000 geothermal springs in New Zealand. *Nat. Commun.* 247759. <https://doi.org/10.1101/247759>. <https://doi.org/10.1038/s41467-018-05020-y>
- Priest, F.G., Goodfellow, M., Todd, C., 1988. A numerical classification of the genus *Bacillus*. *Microbiology.* 134, 1847–1882. <https://doi.org/10.1099/00221287-134-7-1847>
- Promega, 2018. Technical manual, pGEM®-T and pGEM®-T easy vector systems. Instructions for use of products A1360, A1380, A3600 and A3610. Revised 12/18, USA. <https://www.promega.com>
- Promega, 2019. Technical manual, Wizard® Genomic DNA purification Kit instructions for use of products A1120, A1123, A1125, and A1620. Revised 3/19, USA. <https://www.promega.com>
- Qiagen, 2017. DNeasy powersoil DNA isolation handbook for the isolation of microbial genomic DNA from all soil types. <https://www.qiagen.com>
- Quattrini, S., Pampaloni, B., Brandi, M. L., 2016. Natural mineral waters: chemical characteristics and health effects. Clinical cases in mineral and bone metabolism. The official journal of the Italian Society of Osteoporosis, Mineral Metabolism, and Skeletal Diseases. 13(3), 173–180. <https://doi.org/10.11138/ccmbm/2016.13.3.173>
- Rajkumari, J., Bhuyan, B., Das, N., Pandey, P., 2019. Environmental applications of microbial extremophiles in the degradation of petroleum hydrocarbons in extreme environments. *Environ. Sustain.* <https://doi.org/10.1007/s42398-019-00065-1>

- Rasmussen, B., 2000. Filamentous microfossils in a 3,235-million-year-old volcanogenic massive sulphide deposit. *Nature*. 405, 676-679. <http://doi: 10.1038/35015063>
- R-Core Team, 2015. R: A language and environment for statistical computing. R Foundation for Statistical Computing, Vienna, Austria. URL <http://www.R-project.org/>
- Renaut, R.W., Jones, B., 2011. Hydrothermal environments, terrestrial. In: Reitner, J., Thiel, V. *Encyclopedia of geobiology*. Encyclopedia of earth sciences series. Springer, Dordrecht.
- Reysenbach, A., 2015. *Thermoprotei* class. nov., in: Bergey's Manual of Systematics of *Archaea* and *Bacteria*. pp. 1–1. <https://doi.org/10.1002/9781118960608.cbm00018>
- Rhoades, J.D., 1992. Instrumental field methods of salinity appraisal. SSSA Special Publications. <https://doi.org/10.2136/sssaspecpub30.c12>.
- Rodier J., Legube B., and Merlet N., 2016. L'analyse de l'eau - Eaux naturelles, eaux résiduaires, eau de mer. 10<sup>th</sup> edition. DUNOD.
- Rodgers, T., Zhang, H., 2019. Recent advances in function-based metagenomic screening. *Genomics proteomics bioinformatics*. 16, 405–415. <https://doi.org/10.1016/j.gpb.2018.01.002>
- Rouahna, H., 2019. Individualisation de gypse dans les sols de la plaine d'El Outaya. Ph.D. Thesis in Pedology. University of Biskra, Algeria. pp. 125
- Roy, C., Rameez, M.J., Haldar, P.K., Peketi, A., Mondal, N., Bakshi, U., Mapder, T., Pyne, P., Fernandes, S., Bhattacharya, S., Roy, R., Mandal, S., O'Neill, W.K., Mazumdar, A., Mukhopadhyay, S.K., Mukherjee, A., Chakraborty, R., Hallsworth, J.E., Ghosh, W., 2020. Microbiome and ecology of a hot spring-microbialite system on the Trans-Himalayan Plateau. *Sci. Rep.* 10, 1–23. <https://doi.org/10.1038/s41598-020-62797-z>
- Royter, M., Schmidt, M., Elend, C., Höbenreich, H., Schäfer, T., Bornscheuer, U.T., Antranikian, G., 2009. Thermostable lipases from the extreme thermophilic anaerobic bacteria *Thermoanaerobacter thermohydrosulfuricus* SOL1 and *Caldanaerobacter subterraneus* subsp. *tengcongensis*. *Extremophiles*. 13, 769–783. <https://doi.org/10.1007/s00792-009-0265-z>
- Sabath, N., Ferrada, E., Barve, A., Wagner, A., 2013. Growth temperature and genome size in bacteria are negatively correlated, suggesting genomic streamlining during thermal adaptation. *Genome Biol. Evol.* 5, 966–977. <https://doi.org/10.1093/gbe/evt050>
- Sahay, H., Yadav, A.N., Singh, A.K., Singh, S., Kaushik, R., Saxena, A.K., 2017. Hot springs of Indian Himalayas: Potential sources of microbial diversity and thermostable hydrolytic enzymes. *3 Biotech.* 7, 1–11. <https://doi.org/10.1007/s13205-017-0762-1>
- Sahoo, R.K., Das, A., Sahoo, K., Sahu, A., Subudhi, E., 2020. Characterization of novel metagenomic-derived lipase from Indian hot spring. *Int. Microbiol.* 23, 233–240. <https://doi.org/10.1007/s10123-019-00095-z>
- Saibi, H., 2009. Geothermal resources in Algeria. *Renew. Sustain. Energy Rev.* 13, 2544–2552. <https://doi.org/10.1016/j.rser.2009.06.019>
- Saitou, N., Nei, M., 1987. The neighbor-joining method: a new method for reconstructing phylogenetic trees. *Mol. Biol. Evol.* 4, 406–25. <https://doi.org/10.1093/oxfordjournals.molbev.a040454>
- Sambrook, J., Fritsch, E.F. Maniatis, T. 1989. *Molecular cloning: a laboratory manual*, 2<sup>nd</sup> edition. Cold Spring Harbor Laboratory Press, Cold Spring Harbor, NY
- Santos, O. Dos, De Resende, M.C.C., De Mello, A.L., Frazzon, A.P.G., D'azevedo, P.A., 2012.

- The use of whole-cell protein profile analysis by SDS-PAGE as an accurate tool to identify species and subspecies of coagulase-negative *Staphylococci*. *APMIS* 120, 39–46. <https://doi.org/10.1111/j.1600-0463.2011.02809.x>
- Santos, H., Lamosa, P., Faria, T.Q., Pais, T.M., De la Paz, M.L., Serrano, L., 2008. Compatible solutes of hyperthermophiles and their role in protein stabilization. In: Robb F., Antranikian, G., Grogan, D., Driessen, A., *Thermophiles: biology and technology at high temperatures*. CRC Press. 1<sup>st</sup> edition
- Satyanarayana, T., Sharma, A., Mehta, D., Puri, A.K., Kumar, V., Nisha, M., Joshi, S., 2012. Biotechnological applications of biocatalysts from the firmicutes *Bacillus* and *Geobacillus* species. In: Satyanarayana, T, Johri, B.N. *Microorganisms in sustainable agriculture and biotechnology*. Springer, Dordrecht, pp. 343–379.
- Saxena, R., Dhakan, D.B., Mittal, P., Waiker, P., Chowdhury, A., Ghatak, A., Sharma, V.K., 2017. Metagenomic analysis of hot springs in central India reveals hydrocarbon degrading thermophiles and pathways essential for survival in extreme environments. *Front. Microbiol.* 7, 2123. <https://doi.org/10.3389/fmicb.2016.02123>
- Schaeffer, A.B., Fulton, M.D., 1933. A simplified method of staining endospores. *Science*. 77, 194. doi:10.1126/science.77.1990.194. <https://doi:10.1126/science.77.1990.194>.
- Schallmeyer, M., Singh, A., Ward, O.P., 2004. Developments in the use of *Bacillus* species for industrial production. *Can. J. Microbiol.* <https://doi.org/10.1139/w03-076>
- Selvarajan, R., Sibanda, T., Tekere, M., 2018. Thermophilic bacterial communities inhabiting the microbial mats of “indifferent” and chalybeate (iron-rich) thermal springs: Diversity and biotechnological analysis. *Microbiologyopen*. 7, e00560. <https://doi.org/10.1002/mbo3.560>
- Sen, R., Tripathy, S., Padhi, S.K., Mohanty, S., Maiti, N.K., 2015. Assessment of genetic diversity of *Bacillus* spp. isolated from eutrophic fish culture pond. *3 Biotech* 5, 393–400. <https://doi.org/10.1007/s13205-014-0234-9>
- Sevim, E., Inan Bektas, K., Sevim, A., Canakci, S., Sahin, I., Belduz, A.O., 2017. Purification and characterization of  $\alpha$ -L-arabinofuranosidases from *Geobacillus stearothermophilus* strain 12. *Biol.* 72, 831–839. <https://doi.org/10.1515/biolog-2017-0099>
- Sharma, B.K., 2007. *Environmental Chemistry: comprehensively covering the UGC syllabus*. Eleventh Edition. Goal Publishing House.
- Sharma, A., Meena, K.R., Kanwar, S.S., 2018. Molecular characterization and bioinformatics studies of a lipase from *Bacillus thermoamylovorans* BHK67. *Int. J. Biol. Macromol.* 107, 2131–2140. <https://doi.org/10.1016/j.ijbiomac.2017.10.092>
- Sharma, A., Paul, D., Dhotre, D., Jani, K., Pandey, A., Shouche, Y.S., 2017. Deep sequencing analysis of bacterial community structure of Soldhar hot spring. *India. Microbiol.* 86, 136–142. <https://doi.org/10.1134/S0026261717010118>
- Sharma, N., Kumar, J., Abedin, M.M., Sahoo, D., Pandey, A., Rai, A.K., Singh, S.P., 2020. Metagenomics revealing molecular profiling of community structure and metabolic pathways in natural hot springs of the Sikkim Himalaya. *BMC Microbiol.* 20, 246. <https://doi.org/10.1186/s12866-020-01923-3>
- Shivlata, L., Satyanarayana, T., 2015. Thermophilic and alkaliphilic *Actinobacteria*: Biology and potential applications. *Front. Microbiol.* 6, 1–29. <https://doi.org/10.3389/fmicb.2015.01014>
- Sierra, G., 1957. A simple method for the detection of lipolytic activity of micro-organisms and some observations on the influence of the contact between cells and fatty substrates.

Antonie Van Leeuwenhoek 23, 15–22. <https://doi.org/10.1007/BF02545855>

- Siliakus, M.F., Oost, J. Van Der, Kengen, S.W.M., 2017. Adaptations of archaeal and bacterial membranes to variations in temperature, pH and pressure. *Extremophiles* 21, 651–670. <https://doi.org/10.1007/s00792-017-0939-x>
- Singh, A.K., Tripathi, B.M., Sahay, H., Singh, R.N., Kaushik, R., Saxena, A.K., Arora, D.K., 2010. Biochemical and molecular characterization of thermo-alkali tolerant xylanase producing bacteria from thermal springs of Manikaran. *Indian J. Microbiol.* 50, 2–9. <https://doi.org/10.1007/s12088-010-0071-4>
- Skeh, A., Pionka, E., Holt, J.G., Krieg, N.R. 2007. Enrichment and isolation In : *Methods for general and molecular microbiology*. 3<sup>rd</sup> edition, ASM press, USA.
- Soares, M.M.C.N., Da Silva, R., Gomes, E., 1999. Screening of bacterial strains for pectinolytic activity: Characterization of the polygalacturonase produced by *Bacillus* sp. *Rev. Microbiol.* 30, 299–303. <https://doi.org/10.1590/S0001-37141999000400002>
- Song, Z., Zhi, X., Li, W., Jiang, H., Zhang, C., Dong, H., 2009. Actinobacterial diversity in hot springs in Tengchong (China), Kamchatka (Russia), and Nevada (USA). *Geomicrobiol. J.* 26, 256–263. <https://doi.org/10.1080/01490450902892373>
- Sonney, R., 2010. Groundwater flow, heat and mass transport in geothermal systems of a Central Alpine Massif. The cases of Lavey-les-Bains, Saint-Gervais-les-Bains and Val d’Illiez. Ph.D. Thesis in Geo-chemistry, University of Neuchâtel, Suisse. pp. 342
- Spanevello, M.D., Patel, B.K.C., 2004. The phylogenetic diversity of *Thermus* and *Meiothermus* from microbial mats of an Australian subsurface aquifer runoff channel. *FEMS Microbiol. Ecol.* 50, 63–73. <https://doi.org/10.1016/j.femsec.2004.05.008>
- Stambouli, A.B., Khiat, Z., Flazi, S., Kitamura, Y., 2012. A review on the renewable energy development in Algeria: Current perspective, energy scenario and sustainability issues. *Renew. Sustain. Energy Rev.* 16, 4445–4460. <https://doi.org/10.1016/j.rser.2012.04.031>
- Stan-Lotter H, 2017. Physiological boundaries of life. In: Stan-Lotter, H, Fendrihan, S. *Adaptation of microbial life to environmental extremes*. Springer International Publishing, pp. 1-21.
- Stetter, K.O., 2006a. Hyperthermophiles in the history of life. *Philos. Trans. R. Soc. B Biol. Sci.* 361, 1837–1842. <https://doi.org/10.1098/rstb.2006.1907>
- Stetter, K.O, 2006b. History of discovery of the first hyperthermophiles. *Extremophiles.* 10, 357–362. <https://doi.org/10.1007/s00792-006-0012-7>
- Stetter, K.O., 1999. Extremophiles and their adaptation to hot environments. *FEBS Lett.* 452, 22–25. [https://doi.org/10.1016/S0014-5793\(99\)00663-8](https://doi.org/10.1016/S0014-5793(99)00663-8)
- Stetter, K.O, Thomm, M., Winter, J., Wildgruber, G., Huber, H., Zillig, W., Janecovic, D., Koning, H., Palm, P., Wunderl, S., 1981. *Methanothermus fervidus*, sp. nov., a novel extremely thermophilic methanogen isolated from an Icelandic hot spring. *Zbl. Bakt Hyg I Abt Orig C2*:166–178. [https://doi.org/10.1016/S0721-9571\(81\)80038-5](https://doi.org/10.1016/S0721-9571(81)80038-5)
- Stone, E.T., Murray, R., College, H., Moran, M.D., 2018. Microbial diversity in the thermal springs within hot springs National Park. *JAAS.* 72(9), 31-37.
- Takai, K., Nakamura, K., Toki, T., Tsunogai, U., Miyazaki, M., Miyazaki, J., Hirayama, H., Nakagawa, S., Nunoura, T., Horikoshi, K., 2008. Cell proliferation at 122°C and isotopically heavy CH<sub>4</sub> production by a hyperthermophilic methanogen under high-pressure cultivation. *Proc. Natl. Acad. Sci. U.S.A.* 105, 10949–10954. <https://doi.org/10.1073/pnas.0712334105>

- Tamura, K., Stecher, G., Peterson, D., Filipowski, A., Kumar, S., 2013. MEGA6: Molecular evolutionary genetics analysis version 6.0. *Mol. Biol. Evol.* 30, 2725–9. <https://doi.org/10.1093/molbev/mst197>
- Tang, J., Liang, Y., Jiang, D., Li, L., Luo, Y., Shah, M.M.R., Daroch, M., 2018. Temperature-controlled thermophilic bacterial communities in hot springs of western Sichuan, China. *BMC Microbiol.* 18, 1–14. <https://doi.org/10.1186/s12866-018-1271-z>
- Tang, Y.W., Ellis, N.M., Hopkins, M.K., Smith, D.H., Dodge, D.E., Persing, D.H., 1998. Comparison of phenotypic and genotypic techniques for identification of unusual aerobic pathogenic gram-negative bacilli. *J. Clin. Microbiol.* 36, 3674–9.
- Teichtmann, S.M., Colman, A.S., Robb, F.T., 2009. “That which does not kill us only makes us stronger”: The role of carbon monoxide in thermophilic microbial consortia: Minireview. *Environ. Microbiol.* 11, 1027–1037. <https://doi.org/10.1111/j.1462-2920.2009.01865.x>
- Temsaa, H.R., Azmy, A.F., Raslan, M., Ahmed, A.E., Hozayen, W.G., 2018. Isolation and characterization of thermophilic enzymes producing microorganisms for potential therapeutic and industrial use. *J. Pure Appl. Microbiol.* 12, 1687–1702. <https://doi.org/10.22207/JPAM.12.4.02>
- Thakur, M., Sharma, N., Rai, A.K., Singh, S.P., 2021. A novel cold-active type I pullulanase from a hot-spring metagenome for effective debranching and production of resistant starch. *Bioresour. Technol.* 320, 124288. <https://doi.org/10.1016/j.biortech.2020.124288>
- Thermo Fisher Scientific, 2012. Technical manual, GeneJET Plasmid Miniprep Kit, K0502. USA. <https://www.thermofisher.com/order/catalog/product/K0502#/K0502>
- Tikhonova, E.N., Kravchenko, I.K., 2019. Activity and diversity of aerobic methanotrophs in thermal springs of the Russian Far East. In: Gupta, V. *New and future developments in microbial biotechnology and bioengineering.* Elsevier, pp. 1–30. <https://doi.org/10.1016/B978-0-444-64191-5.00001-8>
- Tindall, Brian J., Rosselló-Móra, R., Busse, H.J., Ludwig, W., Kämpfer, P., 2010. Notes on the characterization of prokaryote strains for taxonomic purposes. *Int. J. Syst. Evol. Microbiol.* 60, 249–266. <https://doi.org/10.1099/ijs.0.016949-0>
- Tindall, Brian J., Sikorski, J., Lucas, S., Goltsman, E., Copeland, A., del Rio, T.G., Nolan, M., Tice, H., Cheng, J.F., Han, C., Pitluck, S., Liolios, K., Ivanova, N., Mavromatis, K., Ovchinnikova, G., Pati, A., Fährnich, R., Goodwin, L., Chen, A., Palaniappan, K., Land, M., Hauser, L., Chang, Y.J., Jeffries, C.D., Rohde, M., Göker, M., Woyke, T., Bristow, J., Eisen, J.A., Markowitz, V., Hugenholtz, P., Kyrpides, N.C., Klenk, H.P., Lapidus, A., 2010. Complete genome sequence of *Meiothermus ruber* type strain (21T). *Stand. Genomic Sci.* 3, 26–36. <https://doi.org/10.4056/sigs.1032748>
- Tobler, D.J., Benning, L.G., 2011. Bacterial diversity in five Icelandic geothermal waters: Temperature and sinter growth rate effects. *Extremophiles.* 15, 473–485. <https://doi.org/10.1007/s00792-011-0378-z>
- Tsakalidou, E., Manolopoulou, E., Kabaraki, E., Zoidou, E., Pot, B., Kersters, K., Kalantzopoulos, G., 1994. The combined use of whole-cell protein extracts for the identification (SDS-PAGE) and enzyme activity screening of lactic acid bacteria isolated from traditional Greek dairy products. *Syst. Appl. Microbiol.* 17, 444–458. [https://doi.org/10.1016/S0723-2020\(11\)80062-7](https://doi.org/10.1016/S0723-2020(11)80062-7)
- Urbietta, M.S., Donati, E.R., Chan, K.G., Shahar, S., Sin, L.L., Goh, K.M., 2015. Thermophiles in the genomic era: Biodiversity, science, and applications. *Biotechnol. Adv.* 33, 633–647. <https://doi.org/10.1016/j.biotechadv.2015.04.007>
- Valeriani, F., Crognale, S., Protano, C., Gianfranceschi, G., Orsini, M., Vitali, M., Spica, V.R.,

2018. Metagenomic analysis of bacterial community in a travertine depositing hot spring. *New Microbiol.* 41 (2), 126–135. PMID: 29498741.
- Valverde, A., Tuffin, M., Cowan, D.A., 2012. Biogeography of bacterial communities in hot springs: A focus on the *Actinobacteria*. *Extremophiles* 16, 669–679. <https://doi.org/10.1007/s00792-012-0465-9>
- Vancanneyt, M., Torck, U., Dewettinck, D., Vaerewijck, M., Kersters, K., 1996. Grouping of Pseudomonads by SDS-PAGE of whole-cell proteins. *Syst. Appl. Microbiol.* 19, 556–568. [https://doi.org/10.1016/S0723-2020\(96\)80027-0](https://doi.org/10.1016/S0723-2020(96)80027-0)
- Vandamme, P., Torck, U., Falsen, E., Pot, B., Goossens, H., Kersters, K., 2009. Whole-cell protein electrophoretic analysis of viridans *Streptococci*: evidence for heterogeneity among *Streptococcus mitis* biovars. *Int. J. Syst. Bacteriol.* 48, 117–125. <https://doi.org/10.1099/00207713-48-1-117>
- Velmurugan, A., Swarnam, P., Subramani, T., Meena B., and Kaledhonkar M.J. 2020. Water demand and salinity, desalination challenges and opportunities. *IntechOpen*. <https://doi.org/10.5772/intechopen.88095>
- Vikso-Nielsen, A., Andersen, C., Hoff, T., Pedersen, S., 2006. Development of new  $\alpha$ -amylases for raw starch hydrolysis. *Biocatal. Biotransformation* 24, 121–127. <https://doi.org/10.1080/10242420500519191>
- Vos, P., Garrity, G., Jones, D., Krieg, N.R., Ludwig, W., Rainey, F.A., Schleifer, K.-H., Whitman, W., 2009. *Bergey's Manual of Systematic Bacteriology*. Volume 3: The *Firmicutes*. Springer-Verlag New York. <https://doi.org/10.1007/978-0-387-68489-5>. pp. 1181
- Wang, Q., Cen, Z., Zhao, J., 2021. The Survival mechanisms of thermophiles at high temperatures: An angle of omics base biases of thermophilic. 97–106. <https://doi.org/10.1152/physiol.00066.2013>
- Wang, J., Salem, D.R., Sani, R.K., 2019. Extremophilic exopolysaccharides: A review and new perspectives on engineering strategies and applications. *Carbohydr. Polym.* 205, 8–26. <https://doi.org/10.1016/j.carbpol.2018.10.011>
- Wang, S., Hou, W., Dong, H., Jiang, H., Huang, L., Wu, G., Zhang, C., Song, Z., Zhang, Y., Ren, H., Zhang, J., Zhang, L., 2013. Control of temperature on microbial community structure in hot springs of the Tibetan Plateau. *PLoS One* 8. <https://doi.org/10.1371/journal.pone.0062901>
- Ward, L.M., Idei, A., Terajima, S., Kakegawa, T., Fischer, W.W., McGlynn, S.E., 2017. Microbial diversity and iron oxidation at Okuoku-hachikurou Onsen, a Japanese hot spring analog of Precambrian iron formations. *Geobiology*. 15, 817–835. <https://doi.org/10.1111/gbi.12266>
- Webb, M.D., Ewbank, G., Perkins, J., McCarthy, A.J., 2001. Metabolism of pentachlorophenol by *Saccharomonospora viridis* strains isolated from mushroom compost. *Soil Biol. Biochem.* 33, 1903–1914. [https://doi.org/10.1016/S0038-0717\(01\)00115-8](https://doi.org/10.1016/S0038-0717(01)00115-8)
- Weiner, E.R., 2008. *Applications of Environmental Aquatic Chemistry. A practical guide*. Second Edition. CRC Press, Taylor & Francis Group
- Wells-Bennik, M.H.J., Janssen, P.W.M., Klaus, V., Yang, C., Zwietering, M.H., Den Besten, H.M.W., 2019. Heat resistance of spores of 18 strains of *Geobacillus stearothermophilus* and impact of culturing conditions. *Int. J. Food Microbiol.* 291, 161–172. <https://doi.org/10.1016/j.ijfoodmicro.2018.11.005>
- White, D., Sharp, R.J., Priest, F.G., 1994. A polyphasic taxonomic study of thermophilic *Bacilli* from a wide geographical area. *Antonie Van Leeuwenhoek*. 64, 357–386.

<https://doi.org/10.1007/BF00873093>

- W.H.O., 2017. Guidelines for drinking-water quality. 4<sup>th</sup> edition incorporating the First Addendum. Geneva: World Health Organization. 10, Acceptability aspects: taste, odour and appearance. Available from: <https://www.ncbi.nlm.nih.gov/books/NBK442378/>
- Wilkins, L.G.E., Ettinger, C.L., Jospin, G., Eisen, J.A., 2019. Metagenome-assembled genomes provide new insight into the microbial diversity of two thermal pools in Kamchatka, Russia. *Sci. Rep.* 9, 1–15. <https://doi.org/10.1038/s41598-019-39576-6>
- Wilson, P.C., 2013. Water quality notes : Alkalinity and hardness. Univ. Florida, IFAS Ext. 1–6. <https://edis.ifas.ufl.edu>
- Yamada, T., Sekiguchi, Y., 2018a. *Anaerolinea*, in: Bergey's Manual of Systematics of *Archaea* and *Bacteria*. pp. 1–5. <https://doi.org/10.1002/9781118960608.gbm01478>
- Yamada, T., Sekiguchi, Y., 2018b. *Bellilinea*, in: Bergey's Manual of Systematics of *Archaea* and *Bacteria*. pp. 1–3. <https://doi.org/10.1002/9781118960608.gbm01479>
- Yang, B., Wang, Y., Qian, P., 2016. Sensitivity and correlation of hypervariable regions in 16S rRNA genes in phylogenetic analysis. *BMC Bioinformatics* 1–8. <https://doi.org/10.1186/s12859-016-0992-y>
- Yasir, M., Qureshi, A.K., Khan, I., Bibi, F., Rehan, M., Khan, S.B., Azhar, E.I., 2018. Culturomics-based taxonomic diversity of bacterial communities in the hot springs of Saudi Arabia. *Omi. A J. Integr. Biol.* 23, 17–27. <https://doi.org/10.1089/omi.2018.0176>
- Yohandini, H., 2015. Isolation and phylogenetic analysis of thermophile community within Tanjung Sakti hot spring, South Sumatera, Indonesia. *HAYATI J. Biosci.* 22, 143–148. <https://doi.org/10.1016/j.hjb.2015.10.006>
- Yohandini, H., Julinar, Muharni, 2015. Isolation and phylogenetic analysis of thermophile community within Tanjung Sakti Hot Spring, South Sumatera, Indonesia. *HAYATI J. Biosci.* 22, 143–148. <https://doi.org/10.1016/j.hjb.2015.10.006>
- Zhang, J., Kobert, K., Flouri, T., Stamatakis, A., 2014. PEAR: A fast and accurate Illumina Paired-End reAd mergeR. *Bioinformatics* 30, 614–620. <https://doi.org/10.1093/bioinformatics/btt593>
- Zhang, L., Zhao, T., Wang, Q., Li, L., Shen, T., Gao, G., 2019. Bacterial community composition in aquatic and sediment samples with spatiotemporal dynamics in large, shallow, eutrophic Lake Chaohu, China. *J. Freshw. Ecol.* 34, 575–589. <https://doi.org/10.1080/02705060.2019.1635536>
- Zhang, Z., Wang, Y., Ruan, J., 1998. Reclassification of *Thermomonospora* and *Microtetraspora*. *Int. J. Syst. Bacteriol.* 48, 411–422. <https://doi.org/10.1099/00207713-48-2-411>
- Zhou, E.M., Dong, W., Chrisabelle, X., Scott, C.M., Arinola, C.T., 2018. *Thermus sediminis* sp. nov., a thiosulfate - oxidizing and arsenate - reducing organism isolated from Little Hot Creek in the Long Valley Caldera, California. *Extremophiles* 22, 983–991. <https://doi.org/10.1007/s00792-018-1055-2>
- Zillig, W., 2015. *Desulfurococcus*, in: Bergey's Manual of Systematics of *Archaea* and *Bacteria*. pp. 1–3. <https://doi.org/10.1002/9781118960608.gbm00387>
- Zillig, W., Stetter, K.O., Schafer, W., Janekovic, D., Wunderl, S., Holz, I., Palm, P., 1981. *Thermoproteales*: a novel type of extremely thermoacidophilic anaerobic archaeobacteria isolated from Icelandic solfataras. *Zbl. Bakt. Hyg I. Abt. Orig. C2*:205–227. <https://doi.org/10.1007/BF00414725>

# APPENDICIES

# Appendix 1

## Culture media composition

### 1. ATCC medium 697 (Thermus Thermophilus medium)

Components	Quantity
Yeast extract	4.0 g
Proteose peptone Nr. 3	8.0 g
NaCl	2.0 g
Distilled water	1000 ml

-Adjust pH to 7.0.

-Autoclave at 121°C for 15 minutes.

### 2. Thermus 162 medium (Degryse medium)

Components	Quantity
Yeast extract	1.00 g
Tryptone	1.00 g
Nitrilotriacetic acid	100.00 mg
CaSO <sub>4</sub> ×2 H <sub>2</sub> O	40.00 mg
MgCl <sub>2</sub> ×6 H <sub>2</sub> O	200.00 mg
0.01 M Ferric citrate	0.50 ml
Trace element solution (see below)	0.50 ml
Phosphate buffer (see below)	100 ml
Distilled water	900 ml

-Adjust pH to 7.2 with NaOH.

-Autoclave at 121°C for 15 min.

-Autoclave the phosphate buffer separately and then add to the medium.

#### 2.1. Phosphate buffer

Components	Quantity
KH <sub>2</sub> PO <sub>4</sub>	5.44 g
Na <sub>2</sub> HPO <sub>4</sub> ×12 H <sub>2</sub> O	43.00 g
Distilled water	1000 ml

-Adjust pH to 7.2

## 2.2. Trace element solution

Components	Quantity
H <sub>2</sub> SO <sub>4</sub>	0.50 ml
MnSO <sub>4</sub> ×H <sub>2</sub> O	2.28 g
ZnSO <sub>4</sub> ×7 H <sub>2</sub> O	0.50 g
H <sub>3</sub> BO <sub>3</sub>	0.50 g
CuSO <sub>4</sub> ×5 H <sub>2</sub> O	25.00 mg
Na <sub>2</sub> MoO <sub>4</sub> ×2 H <sub>2</sub> O	25.00 mg
CoCl <sub>2</sub> × 6 H <sub>2</sub> O	45.00 mg
Distilled water	1000 ml

## 3. Castenholz medium D

Components	Quantity
Nitrilotriacetic acid	0.1 g
CaSO <sub>4</sub> × 2 H <sub>2</sub> O	0.06 g
MgSO <sub>4</sub> × 7 H <sub>2</sub> O	0.10 g
NaCl	0.008 g
KNO <sub>3</sub>	0.103 g
NaNO <sub>3</sub>	0.689 g
Na <sub>2</sub> HPO <sub>4</sub>	0.111 g
Trace element solution	0.5 ml
FeCl <sub>3</sub> solution	1.0 ml
Distilled water	1000 ml

### 3.1. FeCl<sub>3</sub> Solution

Composition per liter:

FeCl<sub>3</sub> × 6H<sub>2</sub>O..... 2.28g

-Add FeCl<sub>3</sub>·6H<sub>2</sub>O to distilled water and bring volume to 1.0L. Mix thoroughly.

### 3.2. Trace element solution

Components	Quantity
H <sub>2</sub> SO <sub>4</sub>	0.50 ml
MnSO <sub>4</sub> ×H <sub>2</sub> O	2.28 g
ZnSO <sub>4</sub> ×7 H <sub>2</sub> O	0.50 g
H <sub>3</sub> BO <sub>3</sub>	0.50 g
CuSO <sub>4</sub> ×5 H <sub>2</sub> O	25.00 mg
Na <sub>2</sub> MoO <sub>4</sub> ×2 H <sub>2</sub> O	25.00 mg
CoCl <sub>2</sub> × 6 H <sub>2</sub> O	25.00 mg
Distilled water	1000 ml

-Add all components to distilled water and bring volume to 1.0L. Mix thoroughly.

### ***Preparation of Medium***

- Add components to distilled water and bring volume to 1.0L.
- Mix thoroughly
- Adjust pH to 7.5.
- Autoclave at 121°C for 15 min.

## **4. Thermus medium**

<b>Components</b>	<b>Quantity</b>
Nitrilotriacetic acid	0.1 g
Tryptone	1 g
Yeast-extract	1 g
CaSO <sub>4</sub> × 2 H <sub>2</sub> O	0.06 g
MgSO <sub>4</sub> × 7 H <sub>2</sub> O	0.10 g
NaCl	0.008 g
KNO <sub>3</sub>	0.103 g
NaNO <sub>3</sub>	0.689 g
Na <sub>2</sub> HPO <sub>4</sub>	0.111 g
Trace element solution	0.5 ml
FeCl <sub>3</sub> solution	1.0 ml
Distilled water	1000 ml

### **4.1. Trace element solution**

<b>Components</b>	<b>Quantity</b>
H <sub>2</sub> SO <sub>4</sub>	0.50 ml
MnSO <sub>4</sub> × H <sub>2</sub> O	2.28 g
ZnSO <sub>4</sub> × 7 H <sub>2</sub> O	0.50 g
H <sub>3</sub> BO <sub>3</sub>	0.50 g
CuSO <sub>4</sub> × 5 H <sub>2</sub> O	25.00 mg
Na <sub>2</sub> MoO <sub>4</sub> × 2 H <sub>2</sub> O	25.00 mg
CoCl <sub>2</sub> × 6 H <sub>2</sub> O	25.00 mg
Distilled water	1000 ml

- Add all components to distilled water and bring volume to 1.0L.
- Mix thoroughly.

### **4.2. FeCl<sub>3</sub> solution**

<b>Components</b>	<b>Quantity</b>
FeCl <sub>3</sub> × 6H <sub>2</sub> O	1.14 g
Distilled water	500 ml

### ***Preparation of Medium***

- Add components to distilled water and bring volume to 1.0L.
- Mix thoroughly.
- Adjust pH to 7.5.
- Autoclave at 121°C for 15 min.

### **5. Nutrient medium**

<b>Components</b>	<b>Quantity</b>
Yeast extract	2.0 g
Beef extract	1.0 g
Peptone	5.0 g
NaCl	5.0 g
Distilled water	1000 ml

- Adjust pH to 7.5.
- Autoclave at 121°C for 15 min.

### **6. Tryptic soy medium**

<b>Components</b>	<b>Quantity</b>
Pancreatic digest of casein	15.0 g
Papaic digest of soybean meal	5.0 g
NaCl	5.0 g
Distilled water	1000 ml

- Adjust pH to 7.3.
- Autoclave at 121°C for 15 min.

### **7. Mineral Pectin 5 Medium (MP 5 medium)**

<b>Components</b>	<b>Quantity</b>
Agar solution	500 ml
Basal medium	250 ml
Mineral solution	250 ml

- Adjust pH to 6.00.

#### **7.1. Agar Solution**

<b>Components</b>	<b>Quantity</b>
Agar-Agar	15.0 g
Distilled water	500 ml

## 7.2. Basal medium (Composition per 250 ml)

Components	Quantity
Na <sub>2</sub> HPO <sub>4</sub>	6.0 g
Pectin	5.0 g
KH <sub>2</sub> PO <sub>4</sub>	4.0 g
NH <sub>4</sub> SO <sub>4</sub>	2.0 g
Yeast extract	1.0 g

## 7.3. Mineral solution (Composition per 250 ml)

Components	Quantity
FeSO <sub>4</sub> (0.1% solution)	1.0 ml
MgSO <sub>4</sub> × 7H <sub>2</sub> O (20% solution)	1.0 ml
CaCl <sub>2</sub> × 2H <sub>2</sub> O (0.1% solution)	1.0 ml
H <sub>3</sub> BO <sub>3</sub> (0.001% solution)	1.0 ml
MnSO <sub>4</sub> × H <sub>2</sub> O (0.001% solution)	1.0 ml
ZnSO <sub>4</sub> × 7H <sub>2</sub> O (0.007% solution)	1.0 ml
CuSO <sub>4</sub> × 5H <sub>2</sub> O (0.005% solution)	1.0 ml
MoO <sub>3</sub> (0.001% solution)	1.0 ml

- Combine 250.0 ml of basal medium and 250.0 ml of mineral solution.
- Mix thoroughly.
- Adjust pH to 6.0 with 1N HCl.
- Autoclave the basal medium-mineral solution and agar solution separately for 15 min at 121°C.
- Cool to 45°–50°C.
- Aseptically combine the two sterile solutions.
- Mix thoroughly.
- Pour immediately into sterile Petri dishes to prevent hydrolysis of the agar.

## 8. Luria-Bertani Broth (LB Broth)

Components	Quantity
Tryptone (Difco)	10.0 g
Yeast extract	5.0 g
NaCl	5.0 g
Distilled water	1000 ml

- Autoclave at 121°C for 15 min.

### 8.1. LB Agar

- To prepare LB agar, add 15 g/l of agar-agar to 1l of LB broth.
- Autoclaves at 121°C for 15 min.
- Pour into sterile Petri dishes.

# Appendix 2

## Solutions composition

### 1. Bradford's reagent

Components	Quantity
Coomassie Brilliant Blue G-250	100 mg
85% Phosphoric Acid (w/v)	100 ml
95% Ethanol	50 ml
Distilled Water	750 ml

-Filter through Whatman #1 paper.

- Store it in an amber glass bottle at 4°C.

### 2. Laemmli sample buffer

Components	Quantity
Tris-Hcl pH=6.8	150 $\mu$ l
10% SDS	400 $\mu$ l
Glycerol	250 $\mu$ l
$\beta$ -Mercaptoethanol	60 $\mu$ l
Bromophenol blue (0.1%)	140 $\mu$ l

### 3. Running buffer

Components	Quantity
Glycine	28.80 g
Tris-Base	6 g
10% SDS	20 ml
Distilled Water	1980 ml

### 4. SDS-PAGE gel staining solution

Components	Quantity
Tris-Hcl pH=6.8	150 $\mu$ l
10% SDS	400 $\mu$ l
Glycerol	250 $\mu$ l
$\beta$ -Mercaptoethanol	60 $\mu$ l
Bromophenol blue (0.1%)	140 $\mu$ l

#### 4. TAE 50X

Components	Quantity
Tris-Base	242 g
Glacial acetic acid	57.1 ml
0.5M EDTA pH=8.00	100 ml
Distilled Water	842.9 ml

-To prepare 500 ml of TAE 1X, mix 490 ml of distilled water with 10 ml of TAE 50X.

#### 5. Solution I (Plasmid isolation by alkaline lysis method)

Components	Quantity
Glucose (50 mM)	250 $\mu$ l
Tris-Hcl pH=8.0	125 $\mu$ l
EDTA (10 mM) pH=8.0	100 $\mu$ l
Distilled Water	4525 $\mu$ l
Lysozyme	20 mg

#### 6. TE (Tris/EDTA) buffer

Components	Quantity
Tris-HCl (pH 8.0)	10mM
EDTA (pH 8.0)	1mM

-Sterilize the solution by autoclaving at 121°C for 15min.

-Store the buffer at room temperature.

#### 7. Ethidium Bromide stock solution (10mg/ml)

Components	Quantity
Ethidium Bromide	1 g
Distilled Water	100 ml

-Stir on a magnetic stirrer for several hours to ensure that the dye has dissolved completely.

-Transfer the solution to a dark bottle, wrap the container in aluminum foil, and store it at room temperature.

## **8. Ampicillin stock solution (50mg/ml)**

- Dissolve 0.05 g of ampicillin sodium salt in 1ml of sterile distilled water.
- Filter sterilizes with 0.22 $\mu$ m syringe filter.
- Store frozen at -20°C as 1 ml aliquots.

## **9. X-Gal solution (40mg/ml)**

- Dissolve 0.4 g of X-Gal in 10 ml of N, N-dimethylformamide (DMF).
- Dissolve completely.
- Store the solution in a glass container at -20°C for 6-12 months.
- Protected from light.
- If the solution turns pink, it should be discarded.

## **10. IPTG solution (100mM)**

- Dissolve 2.38 g of IPTG in 8 ml of sterile distilled water.
- Once fully dissolved, bring to a final volume of 10 ml with sterile distilled water.
- Filter sterilize with a 0.22  $\mu$ m syringe filter.
- Store in 1ml aliquots at -20 °C for a longer-term.

## **11. RNase Solution**

- Prepare a 10 mg/ml stock solution of RNase A (Sigma-Aldrich R5500) in 10mM sodium acetate buffer at a pH of 5.2.
- Heat solution to 100°C for 15 minutes.
- Allow mixture to cool to room temperature, and then adjust pH to 7.4 using a one-tenth volume of 1M Tris-HCl pH of 7.4.
- Aliquot into individual use tubes and store at -20°C.
- RNase is stable for up to 6 months when stored properly at -20°C.

## **12. Lysozyme solution (10mg/ml)**

- Dissolve solid lysozyme at a 10mg/ml concentration in 10 mM Tris-HCl (pH 8.0) immediately before use.
- Make sure that the pH of the Tris solution is 8.0 before dissolving the protein (lysozyme will not work efficiently if the pH of the solution is less than 8.0).

### 13. Potassium phosphate buffer (0.1 M)

– **Solution A:** 0.2M of  $\text{Na}_2\text{HPO}_4$ : 28.39 g in 1 liter of distilled water.

– **Solution B:** 0.2M of  $\text{NaH}_2\text{PO}_4$ : 24.0 g in 1 liter of distilled water.

– Preparation of 50 ml 0.1 M phosphate buffer:

Preparation of 0.1M Phosphate Buffer at 25°C		
pH	Volume of Solution A (ml)	Volume of Solution B (ml)
5.8	4.0	46.0
6.0	6.2	43.8
6.2	9.3	40.7
6.4	13.3	36.7
6.6	18.8	31.2
6.8	24.5	25.5
7.0	30.5	19.5
7.2	36.0	14.0
7.4	40.5	9.5
7.6	43.5	6.5
7.8	45.8	4.2
8.0	47.4	2.6

### 14. Acetate buffer

– **Solution A:** 0.2M of sodium acetate trihydrate,  $\text{CH}_3\text{COONa} \cdot 3\text{H}_2\text{O}$ : 27.22 g in 1 liter of distilled water.

– **Solution B:** 0.2M of acetic acid: 12.1 ml of glacial acetic acid in 987.9 ml of distilled water.

– Preparation of 100 ml 0.1 M Acetate Buffer:

Preparation of 0.1M Acetate Buffer at 25°C		
pH	Volume of Solution A (ml)	Volume of Solution B (ml)
3.7	10	90
3.8	12	88
4.0	18	82
4.2	26.5	73.5
4.4	37.0	63.0
4.6	49.0	51.0
4.8	59.0	41.0
5.0	70.0	30.0
5.2	79.0	21.0
5.4	86.0	14.0
5.6	91.0	9.0

## 15. Tris Buffer

– Preparation of 100 ml 0.05 M Tris Buffer

Desired pH (25°C)	Volume of 0.1N HCl (ml)
7.1	45.7
7.2	44.7
7.3	43.4
7.4	42.0
7.5	40.3
7.6	38.5
7.7	36.6
7.8	34.5
7.9	32.0
8.0	29.2
8.1	26.2
8.2	22.9
8.3	19.9
8.4	17.2
8.5	14.7
8.6	12.4
8.7	10.3
8.8	8.5
8.9	7.0
9.0	5.9

-Tris buffer (0.05M) of the desired pH can be made by mixing **50 ml of 0.1M Tris-Base** with the indicated volume of **0.1N HCl** and then adjusting the volume of the mixture to 100 ml with distilled water.

- **0.1M Tris-Base:** Add 121.14 g of Tris-Base and complete to liter with distilled water.
- **0.1N HCl\*:** add 8.3 ml of 37% HCl complete to 1 liter by distilled water.

(\*) HCl: 37% v/v. Specific gravity: 1.19 g/ml (Merck).

# Appendix 3

## Endospore staining method

### 1. Malachite Green solution (5%)

Components	Quantity
Malachite Green	5 g
Distilled Water	100 ml

### 2. Safranin solution (0.5%)

Components	Quantity
Safranin	0.5 g
Ethanol 95%	10 ml
Distilled Water	90 ml

- Prepare smears in the usual manner on separate clean slides.
- Allow the smear to air-dry and heat fix.
- Flood smears with malachite green (5%).
- Place on top of a beaker of water sitting on a warm hot plate, allowing the preparation to steam for 5 minutes (*Do not allow the stain to evaporate; replenish stain as needed, and prevent the dye from boiling by adjusting the hot plate temperature*).
- Remove slides from the hot plate, cool, and wash under slowly running tap water.
- Counterstain with Safranin for 30 seconds.
- Wash with tap water.
- Blot dry slides with bibulous paper.
- Examine under a microscope using oil immersion.
- **Result:** endospore stain green and the vegetative cells stain red to pink.

# Appendix 4

## Bradford protein assay

To create a standard curve, the bovine serum albumin (BSA) was diluted as follows: 50, 100, 150, 200, 250, and 300 µg/ml. The assay was performed as triplicate determination.

Protein concentration (µg/ml)	BSA (1mg/ml)	Distilled Water (µl)
0	-	500
50	25	475
100	50	450
150	75	425
200	100	400
250	125	375
300	150	350

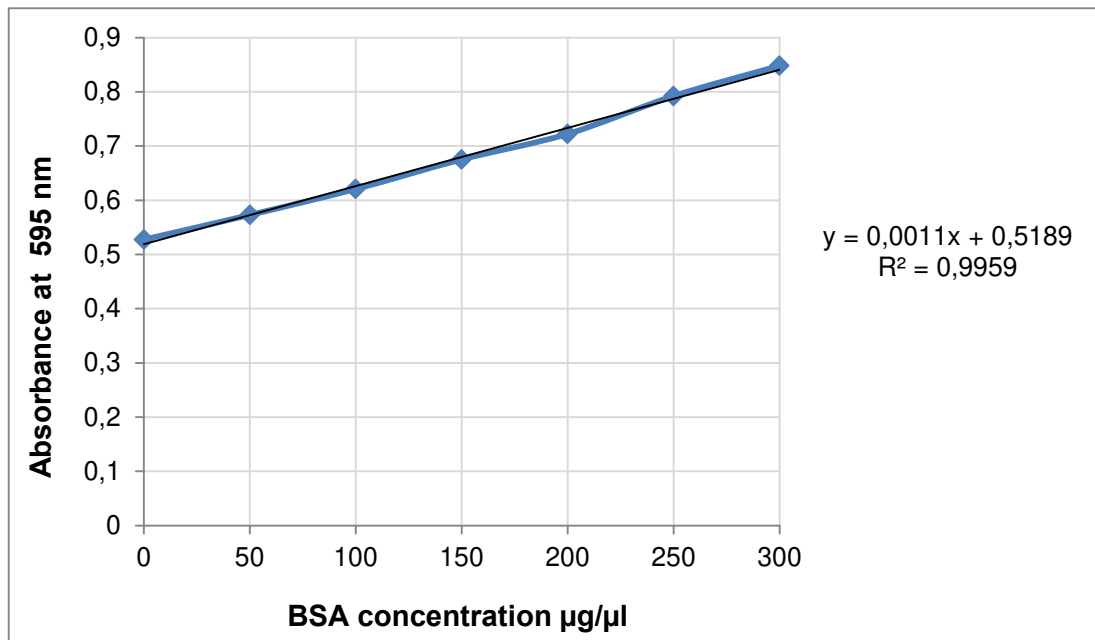
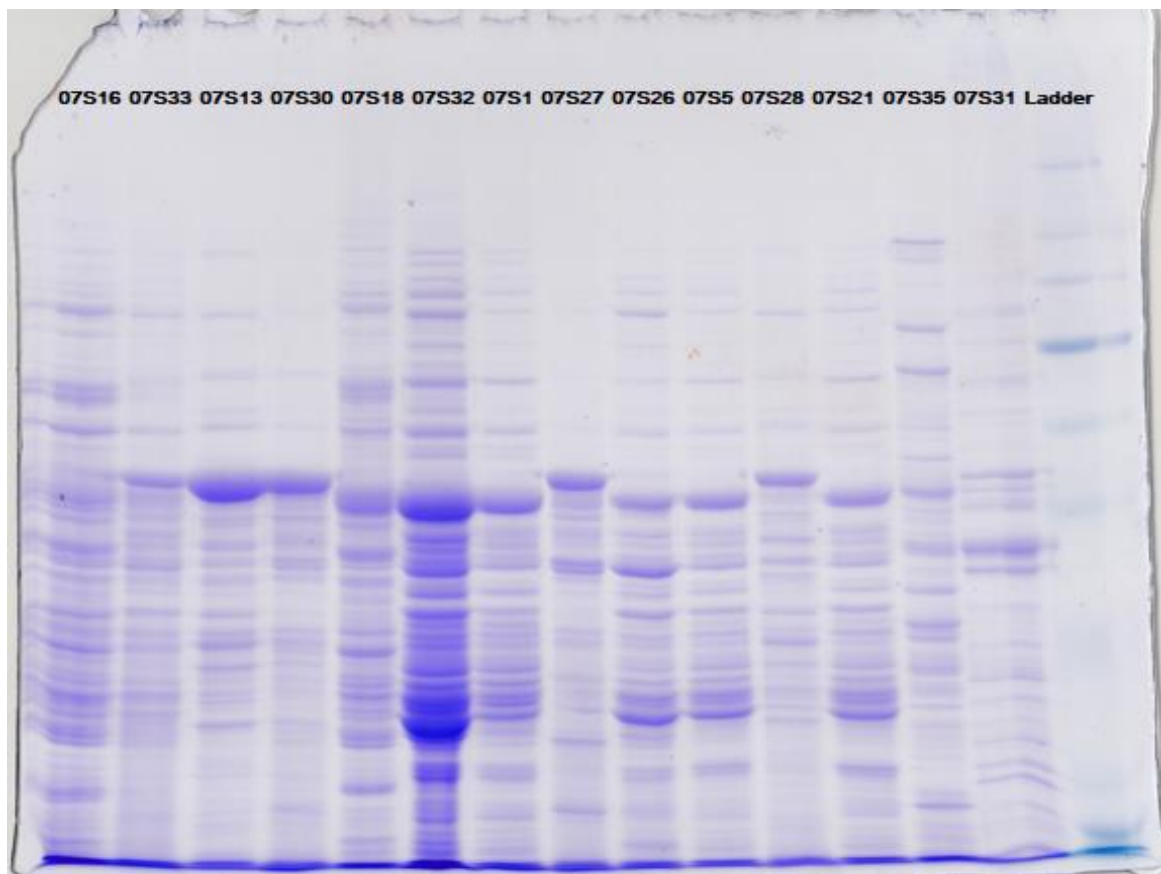
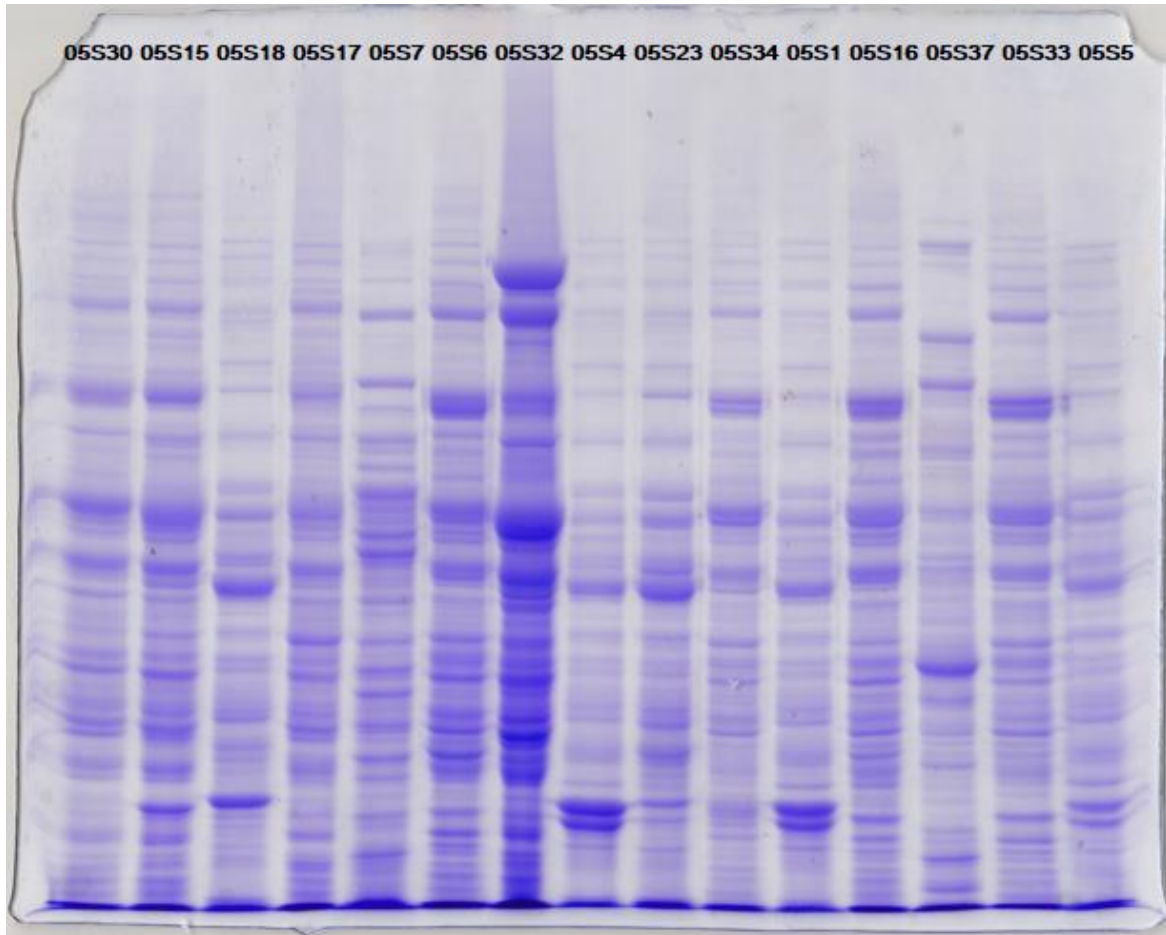

Figure 1. BSA standard curve.

## Example of obtained SDS-PAGE Gels



# Appendix 5

## Physicochemical Analysis

### 1. Total alkalinity

The water to be analyzed was preferably stored in polyethylene containers, and the analysis was performed within 24 hours after sampling.

#### 1.1. Reagents

- 0.02 N hydrochloric or sulfuric acid.
- Phenolphthalein solution in 0.5% alcohol.
- Bromocresol green and methyl red solution:

Components	Quantity
Bromocresol green	0.2 g
Methyl red	0.015 g
Ethanol 90% q.s.	100 ml

– Deionized water free of free carbon dioxide (by boiling for 15 min).

#### 1.2. Operating method

##### **Determination of TA**

Take 100 ml of water to be analyzed in a conical flask. Add 1 to 2 drops of alcoholic solution of phenolphthalein. A pink coloration should then develop. If not, the TA is zero (pH < 8.3), then slowly pour the acid into the flask using a burette while constantly stirring until the solution is wholly discolored (pH 8.3).

*V* is the volume of acid used to obtain the color change.

##### **Determination of TAC**

Use the previously processed sample or the original sample if no staining was done. Add two drops of bromocresol green solution and methyl red and titrate again with the same acid until the greenish-blue coloration disappearance and appearance of the pink color (pH 4.5). The titration must be carried out quickly to reduce the loss of CO<sub>2</sub>, leading to an increase in the pH of the solution.

*V'* be the volume of 0.02 N acid poured since the beginning of the determination.

#### 1.3. Expression of results

##### **TA**

- $V/5$ : expresses the alkalimetric strength (TA) in milliequivalents per liter.

- V expresses the alkalimetric strength in French degrees (1° f corresponds to 10 mg of calcium carbonate or 0.2 mEq/l).

### **TAC**

- V' /5: expresses the complete alkalimetric title (TAC) in milliequivalents per liter.
- V' expresses the complete alkalimetric title in French degrees.

## **2. Total Hardness (TH)**

### **2.1. Reagents**

#### ***0.5% eriochrome black T solution***

<b>Components</b>	<b>Quantity</b>
sodium salt of [(1-hydroxy-2-naphthylazo) nitro-6-naphthol-2-sulfonic acid-4)] (*)	0.5g
Triethanolamine	100 ml

(\*) Marketed under the name of Eriochrome Black T.

#### ***Buffer solution pH=10***

<b>Components</b>	<b>Quantity</b>
Ammonium chloride	67.5g
Ammonia (d = 0.925)	570 ml
EDTA disodium magnesium salt (C <sub>10</sub> H <sub>12</sub> N <sub>2</sub> O <sub>8</sub> Na <sub>2</sub> Mg)	5g
Deionized water	1000 ml

-Keep the solution in a polyethylene bottle.

-Check the pH, which must be equal to 10 on a 1/10 dilution of the solution with deionized water.

#### ***EDTA solution***

<b>Components</b>	<b>Quantity</b>
EDTA	3.725g
Deionized water	1000 ml

-Store the solution in a polyethylene vial and check its titer periodically with the standard calcium solution.

-Take 20 ml of the standard calcium solution, dilute to 50 ml and proceed with the assay as described in the procedure.

-The concentration of the EDTA solution in mol/L is given by the expression:

$$C = 0.01 \times \frac{V1}{V2}$$

v1 = Volume in ml of the standard solution.

v2 = Volume in ml of EDTA solution.

**Calcium standard solution at 0.4008 g/L**

Components	Quantity
Dehydrated calcium carbonate	1.001g
Hydrochloric acid diluted to 1/4	Until dissolved
Methyl red	A few drops
Ammonia diluted to 1/10	Turn on the indicator
Deionized water	1000 ml

-Place the calcium carbonate in a beaker, add 100 ml of water, and then hydrochloric acid in an amount just sufficient to dissolve the calcium carbonate.

-Add 200 ml of water and boil the solution for a few minutes to remove the carbon dioxide.

-After cooling, add a few drops of methyl red and ammonia solutions until the indicator turns orange.

-Transfer the solution into a 1-liter volumetric flask, complete the volume with deionized water.

➤ 1 mL of the solution contains 0.4008 mg of calcium.

**2.2. Operating method**

-Add 50 ml of test water to a 250 ml conical flask, add 4 ml of buffer solution and three drops of eriochrome black T solution. The solution will turn dark red or purple; the pH should be 10. While maintaining agitation, add the EDTA solution rapidly and then dropwise as the solution begins to turn blue. Check that the coloration no longer changes by adding an additional drop of EDTA.

**2.3. Expression of results**

The total concentration of calcium and magnesium, expressed in milliequivalents per liter, is given by the expression:

$$1000 \times \frac{C \times V1}{V2}$$

C = Concentration in milliequivalents per liter of the EDTA solution.

v1 = Volume in ml of EDTA solution.

v2 = Volume of sample.

### 3. Measure of cations

Calcium ( $\text{Ca}^{2+}$ ), Magnesium ( $\text{Mg}^{2+}$ ), Potassium ( $\text{K}^+$ ), Sodium ( $\text{Na}^+$ ) concentrations were determined by flame atomic absorption spectroscopy of type Agilent Technologies 2007 at 422.7 nm, 258.2nm, 766.5 nm, and 589.6 nm, respectively, according to the detailed protocols described in Rodier et al. (2016).

### 4. Chloride

#### 4.1. Reagents

- Pure nitric acid.
- Pure calcium carbonate.
- 10% potassium chromate solution.
- 0.1 N silver nitrate solution.

#### 4.2. Operating method

-Introduce 100 ml of water to be analyzed (previously filtered if necessary). Add 2 to 3 drops of pure nitric acid, then a pinch of carbonate of lime, and three drops of 10% potassium chromate solution. Then pour the silver nitrate solution through a burette until a reddish tint appears. The appearance of a reddish tint, which should persist for 1 to 3 minutes.

*V be the number of milliliters of 0.1 N silver nitrate used.*

#### 4.3. Expression of results

For a 100 ml test sample:

$V \times 10 \times 3.55$  gives the chloride content, expressed in milligrams of  $\text{Cl}^-$  per liter of water.

$V \times 10 \times 5.85$  gives the chloride content expressed in milligrams of  $\text{NaCl}$  per liter of water.

# Appendix 6

## Metagenomics Analysis

### 1. Sequencing data

Samples	Total reads	Total valid reads	Removed reads*	Read lengths (pb)			N° of reads identified at level of species	N° of Species identified
				Min	Max	Average		
<b>Debagh (Sediment)</b>	23 615	18 912 (80.1%)	4703 (19.9%)	264	347	291.9	14795 (78.2%)	349
<b>Saïda (Sediment)</b>	46687	39282 (84.1%)	7405 (15.9%)	229	259	292	29525 (75.2%)	1106
<b>Debagh (Water)</b>	21748	21262 (97.8%)	486 (2.2%)	131	493	291.2	8149 (38.3%)	75
<b>Saïda (Water)</b>	28693	24082 (83.9%)	4611 (16.1%)	286	299	291.9	23299 (96.7%)	276

\* (Low quality, Non-target, Chimeric).



# Diversity and enzymatic potential of thermophilic bacteria associated with terrestrial hot springs in Algeria

L. Benammar<sup>1,2,3</sup> · K. İnan Bektaş<sup>4</sup> · T. Menasria<sup>5</sup> · A. O. Beldüz<sup>2</sup> · H. I. Güler<sup>4</sup> · I. K. Bedaida<sup>1</sup> · J. M. Gonzalez<sup>6</sup> · A. Ayachi<sup>3</sup>

Received: 25 May 2020 / Accepted: 3 September 2020 / Published online: 21 September 2020  
© Sociedade Brasileira de Microbiologia 2020

## Abstract

This study aims to determine the diversity of culturable thermophilic bacteria isolated from eight terrestrial hot springs in Northeastern of Algeria using the conventional methods, SDS-PAGE fingerprinting of whole-cell proteins and 16S rRNA gene sequencing. In addition, their hydrolytic enzyme activities were also investigated. A total of 293 strains were isolated from the hot springs' water and sediment using different culture media. Overall, five distinct bacterial groups were characterized by whole-cell protein pattern analysis. Based on the 16S rRNA gene sequencing of 100 selected strains, the isolates were assigned to the following three major phyla: *Firmicutes* (93%), *Deinococcus-Thermus* (5%), and *Actinobacteria* (2%), which included 27 distinct species belonging to 12 different phylotypes, *Aeribacillus*, *Aneurinibacillus*, *Anoxybacillus*, *Bacillus*, *Brevibacillus*, *Geobacillus*, *Laceyella*, *Meiothermus*, *Saccharomonospora*, *Thermoactinomyces*, *Thermobifida*, and *Thermus*. The screening for nine extracellular enzymes showed that 65.87% of the isolates presented at least five types of enzyme activities, and 6.48% of strains combined all tested enzymes (amylase, cellulase, pectinase, esculinase, protease, gelatinase, lipase, lecithinase, and nuclease). It was found that *Bacillus*, *Anoxybacillus*, *Aeribacillus*, and *Aneurinibacillus* were the genera showing the highest activities. Likewise, the study showed an abundant and diverse thermophilic community with novel taxa presenting a promising source of thermozymes with important biotechnological applications. This study showed that a combined identification method using SDS-PAGE profiles of whole-cell proteins and subsequent 16S rRNA gene sequence analysis could successfully differentiate thermophilic bacteria from Algerian hot springs.

**Keywords** Thermal spring · Algeria · Thermophile · Culture-dependent method · SDS-PAGE fingerprinting · 16S rRNA gene · Biodiversity · Thermozyyme

---

Responsible Editor: Vania M.M. Melo

**Electronic supplementary material** The online version of this article (<https://doi.org/10.1007/s42770-020-00376-0>) contains supplementary material, which is available to authorized users.

✉ L. Benammar  
leyla.benammar@univ-batna2.dz

✉ T. Menasria  
tahamenasria@hotmail.com

<sup>1</sup> Department of Microbiology and Biochemistry, Faculty of Natural and Life Sciences, University of Batna 2, 05078 Batna, Algeria

<sup>2</sup> Molecular Biology Research Laboratory, Department of Biology, Faculty of Science, Karadeniz Technical University, 61080 Trabzon, Turkey

<sup>3</sup> Bacteriology Laboratory, Veterinary and Agricultural Sciences Institute, Department of Veterinary Sciences, University of Batna 1, 05000 Batna, Algeria

<sup>4</sup> Department of Molecular Biology and Genetics, Faculty of Science, Karadeniz Technical University, 61080 Trabzon, Turkey

<sup>5</sup> Department of Applied Biology, Faculty of Exact Sciences and Natural and Life Sciences, University of Larbi Tebessi, 12002 Tebessa, Algeria

<sup>6</sup> Spanish National Research Council Seville (CSIC), Institute of Natural Resources and Agrobiological of Seville (IRNAS), Seville, Spain

## Introduction

Thermophiles are a group of heat-loving microbes thriving at high temperature. They are grouped according to their optimum growth temperature as moderate thermophiles (50–60 °C), extreme thermophiles (60–80 °C), and hyperthermophiles (> 80 °C) [1]. They are inhabitants of various environments, such as deep-sea hydrothermal vents, terrestrial hot springs, and other extreme sites, including volcanic region, tectonically active faults, and processing waste residues, like compost piles and deep organic landfills [2]. Thermophiles have attracted considerable attention because they present specific features with biotechnological and industrial interest, such as the production of different biomolecules (exopolysaccharide, antimicrobial, biosurfactant) [3–5] and thermostable enzymes (amylases, cellulases, chitinases, pectinases, xylanases, proteases, lipase, and DNA polymerases), for biotechnological applications in medical, industrial, and agriculture processes [1]. These organisms may also serve in an increasing number of potential bioremediation applications, mainly removing of heavy metals from waste [6], biodegradation of petroleum hydrocarbons, [7], and in renewable energy [8].

Geothermal springs are considered unique hot spots for large communities of thermophilic microorganisms, mainly belonging to Bacteria and Archaea domains [9]. Thermophile biodiversity can provide an overview of the potential, and such studies are required not only to understand the microbial community's organization and composition but also led to further discovery of novel taxa and to resolve the role of microorganisms in the community [10]. Microbial studies of hot springs have been extensively reported in many countries, particularly the Yellowstone National Park (USA) [11], New Zealand [12], India [13], Russia [14], Japan [15], China [16], Iceland [17], and Turkey [18].

Algeria is one of the world's richest countries in terms of geothermal sites, with over 240 hot springs across the country (temperature ranging between 22 and 98 °C) [19]. Moreover, it hosts Hammam Debagh, also named Hammam Challala that presents temperatures up to 98 °C, which offers the hottest terrestrial spring in the country [20] and the second in the world after those of Iceland [21]. Algerian hot springs formerly were only used as spas for balneology [22], regarding their therapeutic effects [23]. At these spots, researchers were mainly interested in geothermal potential, physicochemical composition, and bacteriological and fungal contamination investigations to ensure the safety of users [24–26]. Despite intensive studies on terrestrial thermal springs around the world, very little is known about the microbial biodiversity of hydrothermal springs in Algeria. Though recently some studies on thermophilic bacteria have emerged, they stay limited only to some hot springs and aspects [27, 28].

The identification of thermophilic species is usually performed by 16S rDNA sequence, DNA-DNA hybridization, PCR-RFLP profiles, and BOX-PCR [29–32]. Nevertheless, during isolation, multiple colonies are simultaneously detected and very often with very close morphologies within and between the strains, which makes the selection of different bacteria difficult; consequently, an efficient technique for species recognition is required before further identification by molecular approaches [2]. The analysis of SDS-PAGE whole-cell protein has demonstrated to be highly effective for the differentiation of thermophilic bacteria [33, 34]. Our study is a first attempt to classify and cluster thermophilic strains isolated from Algerian terrestrial hot spring using SDS-PAGE profiling.

Given these facts, the present study seeks to investigate the culturable thermophilic bacterial diversity using a culture-dependent approach based on SDS-PAGE whole-cell protein patterns and 16S rRNA gene sequencing from eight hot springs distributed over four cities in Northeastern of Algeria. The work was extended by investigating some industrially important hydrolytic enzymes (amylase, cellulase, pectinase, esculinase, protease, gelatinase, lipase, lecithinase, and DNase) from isolated thermophilic strains in order to evaluate their potential application in biotechnological processes.

## Materials and methods

### Site description

The sampling study was carried out in eight terrestrial geothermal springs distributed over four cities (Batna, Biskra, Guelma, and Khenchela) in Northeastern of Algeria. Among the hot springs studied, the following six sites have never been explored for microbial biodiversity: Belhachani Hot Spring (H24A), Guerfa Hot Spring (H24G), Saïda Hot Spring (H05S), Guerdjima Hot Spring (H05G), Sidi El Hadj Hot Spring (H07S), and El Knif Hot Spring (H40K). The hot springs included from moderate thermophilic to hyperthermophilic (40.6–96 °C) environments with a range of pH from 6.27 to 8.03 (Fig. 1).

### Sample collection and isolation of thermophilic bacteria

In order to avoid possible bacterial contamination, water and sediment samples were collected aseptically in sterile flasks, at a depth of 30–50 cm from the surface. For water, physicochemical parameters as temperature and pH were recorded in situ by a portable multiparameter meter (Hanna HI 8314). The collected samples were immediately transported on ice to the laboratory for further analysis.

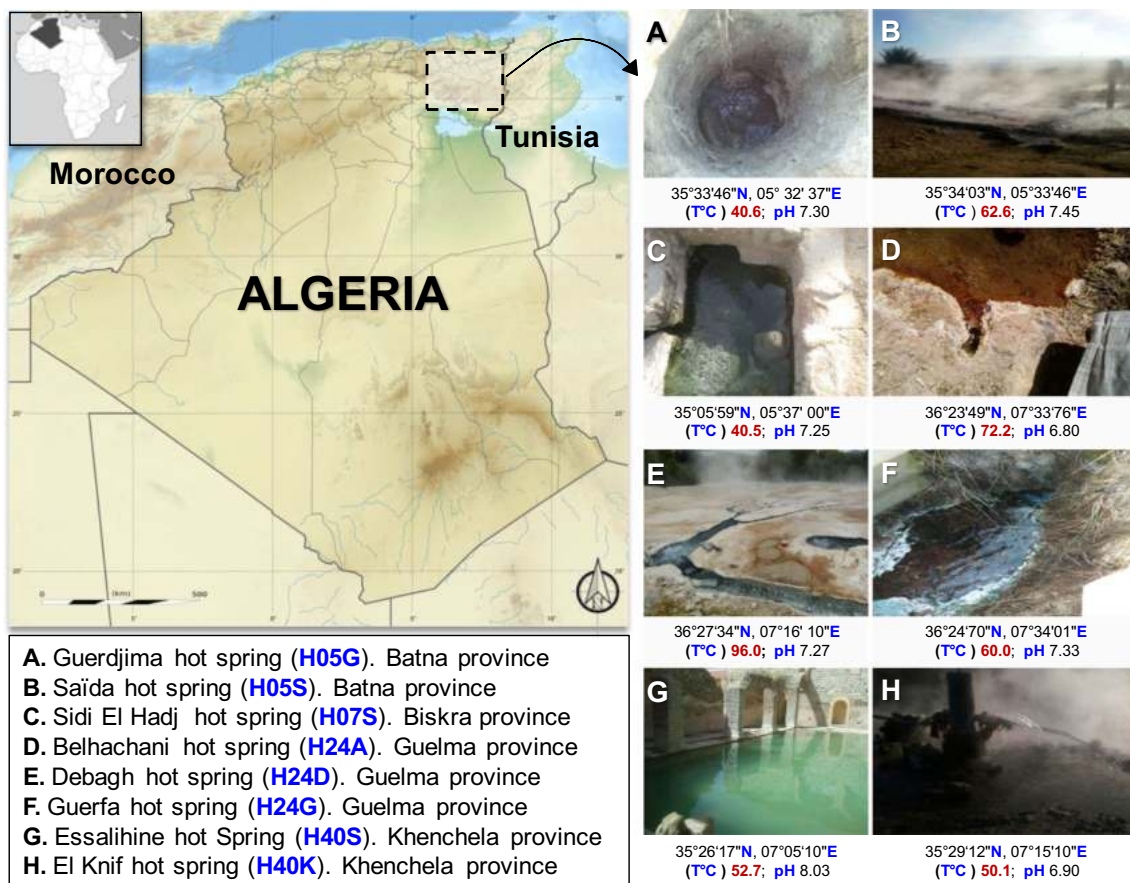

Fig. 1 Geographical location of the studied hot springs

Two techniques, liquid enrichment and dilution plating, were used to isolate the thermophilic bacteria on the following six different culture media: Thermus medium [35], Castenholz medium D, Thermus 162 medium [36], ATCC medium 697 [37], Nutrient medium (Liofilchem) [38], and Tryptic soy medium (BD, Difco) [39]. Solid media were obtained by adding 3% (*w/v*) of agar to liquid media. The plates were then incubated for 3 to 10 days at 55 °C in plastic bags. The plates were constantly observed for the appearance of bacterial colonies in the different employed media. Single colonies with distinct morphology were selected from each of the plates and purified by successive streaking on respective medium plates. Pure cultures were maintained at 4 °C as slant and in 20% glycerol stock at – 80 °C for further use.

### Phenotypic features of isolates

All phenotypic tests were made in duplicate and repeated if inconsistent results were first observed. Growth tests, unless otherwise specified, were performed at 55 °C on Thermus media.

The colony morphology of the thermophilic isolates was checked by direct and stereomicroscopic observations of

single colonies. Gram staining was carried out by using the standard Gram's reaction [40] and was confirmed by a non-staining procedure using the KOH lysis test method [41]. Oxidase and catalase activities were performed as described by Maugeri et al. [42].

Temperature and pH range for growth were determined following incubation of the strains on Thermus agar at different temperatures (30–75 °C) and pH (5.0–9.0) with 5 °C and one unit intervals, respectively. Halotolerance was assayed by plating each culture onto Thermus medium supplemented with 0, 2, 2.5, 5, 7.5, 10, 15, and 20% (*w/v*) NaCl. Growth was determined by visual observation after three days of incubation [43].

Biochemical characteristics were screened by API 20E® strips system (bioMérieux, France) according to the manufacturer's instructions with some modifications. The number of bacteria was adjusted to one McFarland standard, and 200 µL of suspension was transferred into each well. Strips in incubation boxes were put into a plastic container filled into the bottom with sterilized water to minimize evaporation and then incubated at 55 °C. The API strips were observed at 4, 8, 16, and 24 h. At each observation point, water was replenished when necessary.

For further clarification of biochemical characters, a similarity dendrogram of API20E profiles was constructed using the MEGA6 software based on the UPGMA method and Jaccard coefficient.

## SDS-PAGE of whole-cell proteins

### Preparation of protein extracts

Thermophilic strains of 0.1 O.D. at 600 nm were incubated overnight at 55 °C in 50 mL of LB broth and centrifuged at 16,000 ×g for 10 min at 4 °C. Each sample pellet was washed twice with distilled sterile water and suspended in 100 mM phosphate buffer (pH = 7.6). The suspensions were then sonicated with an ultrasonic homogenizer (LABSONIC M, Sartorius) at an output of 40% amplitude and pulse mode of 30 s with 10 s intermittence, for 5–10 min according to bacterial strains. Sample tubes were placed in an ice bath during sonication to prevent heat buildup. All lysates were clarified by centrifugation at 16,000 ×g for 15 min at 4 °C. The supernatant obtained was stored at –20 °C [44]. Protein concentration was measured according to Bradford microplate protein quantification assay. The absorbance was measured at 595 nm with a microplate reader (SpectraMax® M2), and the protein concentration was determined from a standard curve using bovine serum albumin (Thermo-Fisher) as standard protein. Protein samples were then mixed with Laemmli sample buffer (Bio-Rad). For protein denaturation, samples were heated for 5 min at 95 °C and centrifuged at 12,000g for 5 min to prevent streaking during electrophoresis and kept on ice before loading into the wells.

### SDS-PAGE electrophoresis

SDS-PAGE of whole-cell proteins was carried out as described by [45], on vertical slab gels (20 × 20 cm × 1 mm) in a Protean® II xi Cell gel electrophoresis apparatus (Bio-Rad Laboratories), using 12% (w/v) separating and 5% (w/v) stacking gels. A volume of a sample containing 40–50 ng of protein was layered on top of the gel. Electrophoresis was performed at a constant current of 120 V through the stacking gel and 200 V through the resolving gel for 4 h. In each gel, the broad range protein molecular mass marker (11 and 190 kDa, Prestained Protein Ladder, Biolabs) was used to determine the protein molecular mass. After electrophoresis, the gel was stained for 1 h with 200 mL of 0.1% (w/v) Coomassie Brilliant Blue R-250 (Sigma) with gentle continuous shaking and then destained twice with 100 mL of 10% (v/v) acetic acid and 50% (v/v) methanol aqueous solution first for 1 h followed by a second destained solution containing 5% (v/v) methanol, 7% (v/v) acetic acid, and 88% water overnight.

## Computing numerical data

The destained gels were scanned and stored as JPEG files. The whole-cell protein patterns were compared with each other to group the thermophilic isolates. The densitometric analysis, normalization, and interpolation of the protein profiles, grouping of the bacterial strains by the *Pearson* product-moment correlation coefficient (*r*), and cluster analysis on the matrix of correlation values by the unweighted pair group method using arithmetic averages (UPGMA). Linkage was performed using the BioNumerics version 7.6.3 software package (Applied Maths NV).

## Molecular identification by 16S rRNA gene sequencing and phylogenetic analysis

### Genomic DNA extraction

Bacterial genomic DNA of promising isolates was extracted from 5 mL cultures grown overnight at 55 °C in Thermus broth and pelleted by centrifugation at 16,000×g for 2 min using Wizard® Genomic DNA Purification Kit by Promega (USA). DNA was quantified using the Nanodrop 2000 spectrophotometer (Thermo Scientific), by measuring OD<sub>260</sub> and OD<sub>280</sub>.

### PCR amplification

The extracted DNA samples were used as a template for amplification of the 16S rRNA sequences gene using the universal primers UNI16S-L (5'-ATTCTAGAGTTTGATCATGGCTCA-3') and UNI16S-R (5'-ATGGTACCGTGTGACGGGCGGTGTGTA-3') [43]. PCR reactions were carried out in 50 µL volume containing 10 µL GoTaq Flexi Buffer (5×), 3 µL MgCl<sub>2</sub> (25 mM), 1 µL dNTPs (10 mM), 1 µL reverse primer (10 mM), 1 µL forward primer (10 mM), 0.25 µL GoTaq G2 Flexi DNA polymerase (5 U/µL), and 1 µL of the DNA template, and the volume was made up to 50 µL with Milli-Q water. The PCR amplification conditions consisted of initial denaturation at 95 °C for 2 min, followed by 35 cycles of denaturation at 94 °C for 1 min, annealing at 55 °C for 1 min, extension at 72 °C for 2 min, and a final polymerization step of 72 °C for 5 min. PCR products were visualized in 1% (w/v) agarose gel electrophoresis at 120 V for 15 min.

### Sequencing and phylogenetic analysis

The PCR products were cloned into the pGEM-T Easy vector system (Promega, USA), and then, the 16S rRNA gene sequence was determined with an Applied Biosystems model 373A DNA Sequencer, using the ABI PRISM® BigDye™ Terminator cycle-sequencing kit (Macrogen).

The sequences were compared with those in the databases of the National Center for Biotechnology Information (NCBI) website using the BLAST method and the EzTaxon server (<http://www.eztaxon.org/>) [46]. Phylogenetic analyses were carried out using MEGA software version 6 [47]. Phylogenetic trees were constructed using the neighbor-joining method [48]. Tree topologies were evaluated by bootstrap sampling expressed as a percentage of 1000 replicates. The nucleotide sequences determined in this study have been deposited in GenBank (NCBI database) under accession numbers from MN885696 to MN885795.

### Extracellular hydrolytic enzyme screening

For preliminary qualitative screening of ten hydrolytic enzymes, the thermophilic isolates were grown on Thermus agar for 24–48 h. The relevant assays were performed on agar plates, including enzyme-specific substrates using drop plate technique after incubation in plastic bags at 55 °C for 1–5 days. All experiments were done in duplicate and conducted according to the standard protocols described subsequently.

#### Amylase activity

Amylase assay was determined on 1% (*w/v*) starch agar medium. The starch hydrolysis was detected by flooding plates with Lugol's iodine solution. The clear zone around the colony indicates a positive result [49].

#### Cellulase activity

For cellulase activity screening, 0.5% (*w/v*) carboxymethyl-cellulose (CMC)-based medium was used. The plates were flooded with Lugol's iodine solution. The clear halo around the colonies indicates the CMC hydrolysis [50].

#### Pectinase activity

The pectinolytic activity was detected on MP5 medium containing 0.5% pectin [51]. After incubation, the plates were flooded with iodine-potassium iodide solution (1.0 g iodine, 5.0 g potassium iodide, and 330 mL H<sub>2</sub>O). Clear zones around the colonies showed pectinolytic activity [52].

#### Esculinase activity

Esculinase hydrolysis enzyme was screened according to [53] with some modifications using specific medium containing 10 g peptone, 1 g esculin/aesculin, 20 g ferric ammonium citrate, 30 g agar, and 1 L distilled H<sub>2</sub>O. Visualizing a zone of black precipitate around the colonies indicates a positive result.

#### Protease activity

The proteolytic or caseinolytic activity was tested in 10% skim milk plate medium. Transparent clear zones around the growth were considered as an indication of casein activity degradation [54].

#### Gelatinase activity

Gelatin hydrolysis assay was conducted according to the method of Frazier [55] using 0.4% gelatin-based agar. After incubation, degradation of gelatin was seen as a clear zone around colonies, in the somewhat opaque agar. When the plate was flooded with a saturated aqueous solution of ammonium sulfate, a precipitate was formed that made the agar more opaque and enhanced the clear zones around the colonies [56].

#### Lipolytic and esterase activities

Lipolytic activity was detected according to the diffusion agar method on Tween-based medium containing 1% of tween (20 or 80), 10 g Difco Bacto-peptone, 5 g NaCl, 0.1 g CaCl<sub>2</sub>·1H<sub>2</sub>O, 30 g agar-agar, and 1 L distilled H<sub>2</sub>O (pH 7.4). A well visible halo or turbid around the colonies indicated lipolysis [57].

#### Lecithinase activity

For determination of lecithinase enzyme, nutrient agar, including (5%, *v/v*) egg-yolk emulsion, was used. The formation of a white precipitate as opalescence around or beneath the colony revealed lecithinase formation [58].

#### Nuclease activity

DNase activity of the strains was revealed using the DNase test agar medium with methyl green. After incubation, DNase-producing bacteria exhibit a clear zone around growth against a green background [59].

## Results

### Isolation and distribution of thermophilic bacteria

A total of 293 thermophilic strains were isolated from the different hot springs. According to the distribution, 17.57% (52/293) of all the isolated strains were retrieved from Debagh Hot Spring (H24D), followed by Belhachani Hot Spring (H24B), Essalihine Hot Spring (H40S), Guerdjima Hot Spring (H05G), Sidi El Hadj Hot Spring (H07S), and Saïda Hot Spring (H05S) with 16.04, 14.68, 14.33, 12.29, and

11.95%, respectively. El Knif Hot Spring (H40K) and Guerfa Hot Spring (H05G) presented the lowest number of isolates, 6.83% (20/293) and 6.14% (18/293), respectively.

Isolation and purification procedures were carried out with both water and sediment samples. Sediment samples from all hot springs provided 51.32% (166/293) isolates, while water samples allowed the isolation of 48.68% (127/293) isolates. A total of six media were employed to retrieve the culturable bacteria. A total of 57.68% of total isolates have been cultured on specific media (Thermus medium, ATCC medium 697, Thermus 162 medium). In comparison, 42.32% were isolated from standard media distributed into 6.14% from a minimum medium (Castenholz medium D) and 38.18% from standard media (Nutrient agar and Tryptic soy medium).

### Morphological and physiological characterizations of isolates

Morphologically, the isolates showed some variation in color; they were gray, black, creamy and creamy-gray, buff, white and off-white, yellow to bright yellow, pink, orange, and red (Fig. S1). The pigments produced by the isolated species were endocellular and nondiffusible. The colonies show a very wide range of colonial morphologies. Some isolates are circular or irregular in shape with a margin of entire to undulate or crenate uneven edges. They have wrinkled, rough, granular, crusty, or smooth textures, and some may appear finely wrinkled and adherent to the agar surface. They were either opaque or translucent. Another fast-growing mycelial colony was noted.

Based on Gram staining, 78% of the isolates were found mostly to be Gram-positive. A total of 182 isolates (62.12%) were catalase-positive, 71 isolates (24.23%) were oxidase-positive, while 16.72% (49 isolates) were oxidase- and catalase-positive.

All isolates screened for temperature tolerance were able to grow between 30 and 80 °C with variation among strains. It was noted that all isolates (293 isolates) grow at 55 °C within 24 h to 1 week. Of which, 40.20% were found to tolerate 65 °C, 10.87% could tolerate 75 °C, while only 5.11% of isolates could grow at 80 °C. Moreover, 52.82% of isolates could grow at 37 °C.

Salt was not required for growth since all the strains were able to grow in the unsupplemented medium. The isolates tolerated salt concentrations in medium supplemented with 1 to 15% NaCl (*w/v*). While none of the strains were able to grow in medium supplemented with 20% NaCl (*w/v*). The number of strains growing decreased at increasing salt concentration. In addition, the pH values tested ranged from 5.0 to 9.0. Almost all strains grew in pH ranging between 6.5 and 8.5.

**Fig. 2** Dendrogram of similarity based on SDS-PAGE of whole-cell protein pattern analysis from thermophilic bacterial isolates. The right side of the figure presents the strain number and the clustering classification

### SDS-PAGE analysis

The electrophoretic patterns of whole-cellular proteins from all isolates, resulting from SDS-PAGE, showed that five groups could be delineated at a similarity level of 45% (Fig. 2). The cluster I includes 42 strains grouped into the following four sub-clusters: (A) six strains, (B) 15 strains, (C) 12 strains, and (D) nine strains. The cluster II also was grouped into four sub-clusters assembling 171 strains distributed as 134 strains from sub-cluster (C), followed by 23 strains in sub-cluster (B), and both sub-clusters (A) and (D) including seven strains. Finally, clusters III, IV, and V include only one strain for each one belonging to three different hot springs, distributed as 05S37, 07S35, and 24A17, respectively. A total of 100 representative strains from different clusters were selected for further molecular identification by 16S rRNA gene sequencing.

### Characterization by 16S rRNA gene sequencing

Of 293 isolates, 100 bacterial isolates were selected for identification by complete 16S rDNA gene sequencing (~1400 bp). The phylogenetic analysis revealed that the strains were affiliated to 12 different genera (*Bacillus*, *Anoxybacillus*, *Aeribacillus*, *Aneurinibacillus*, *Brevibacillus*, *Thermoactinomyces*, *Meiothermus*, *Geobacillus*, *Thermus*, *Laceyella*, *Thermobifida*, and *Saccharomonospora*), grouping 27 distinct species with 96.09 to 100% of sequence similarity to closely related species (Table 1; Figs. 3, 4, and 5). The strains retrieved from hot springs were distributed over three phyla, *Firmicutes* (93%), *Deinococcus-Thermus* (5%), and *Actinobacteria* (2%). Blast analysis of the 16S rRNA gene sequence indicates that seven strains grouped as *Bacillus*, *Brevibacillus*, *Geobacillus*, *Aneurinibacillus*, and *Thermoactinomyces* may probably constitute new taxa on these genera (Table 1). They present between 96.09 and 98.79% nucleotide sequence similarity with 16S rRNA gene sequences of typed strains.

### Biochemical characterization

The API 20E profiles of the isolates demonstrated biochemical diversity (Fig. S2). All strains were negative for indole and H<sub>2</sub>S production. As one can see, the utilization of carbohydrates varies; negative assimilation results were obtained for rhamnose and saccharose overall strains. The carbohydrate assimilation test was positive for 20% of strains on



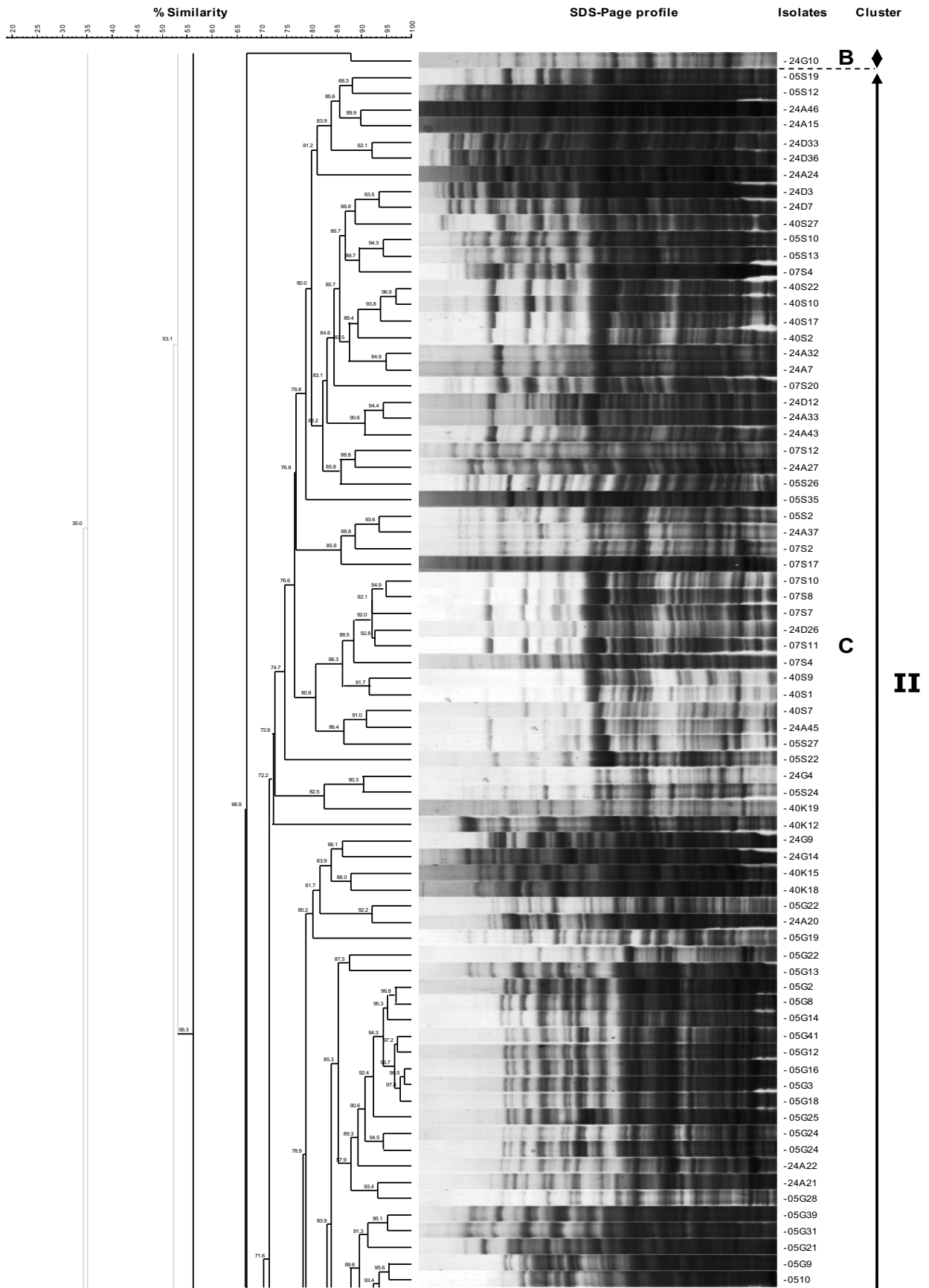

Fig. 2 continued.

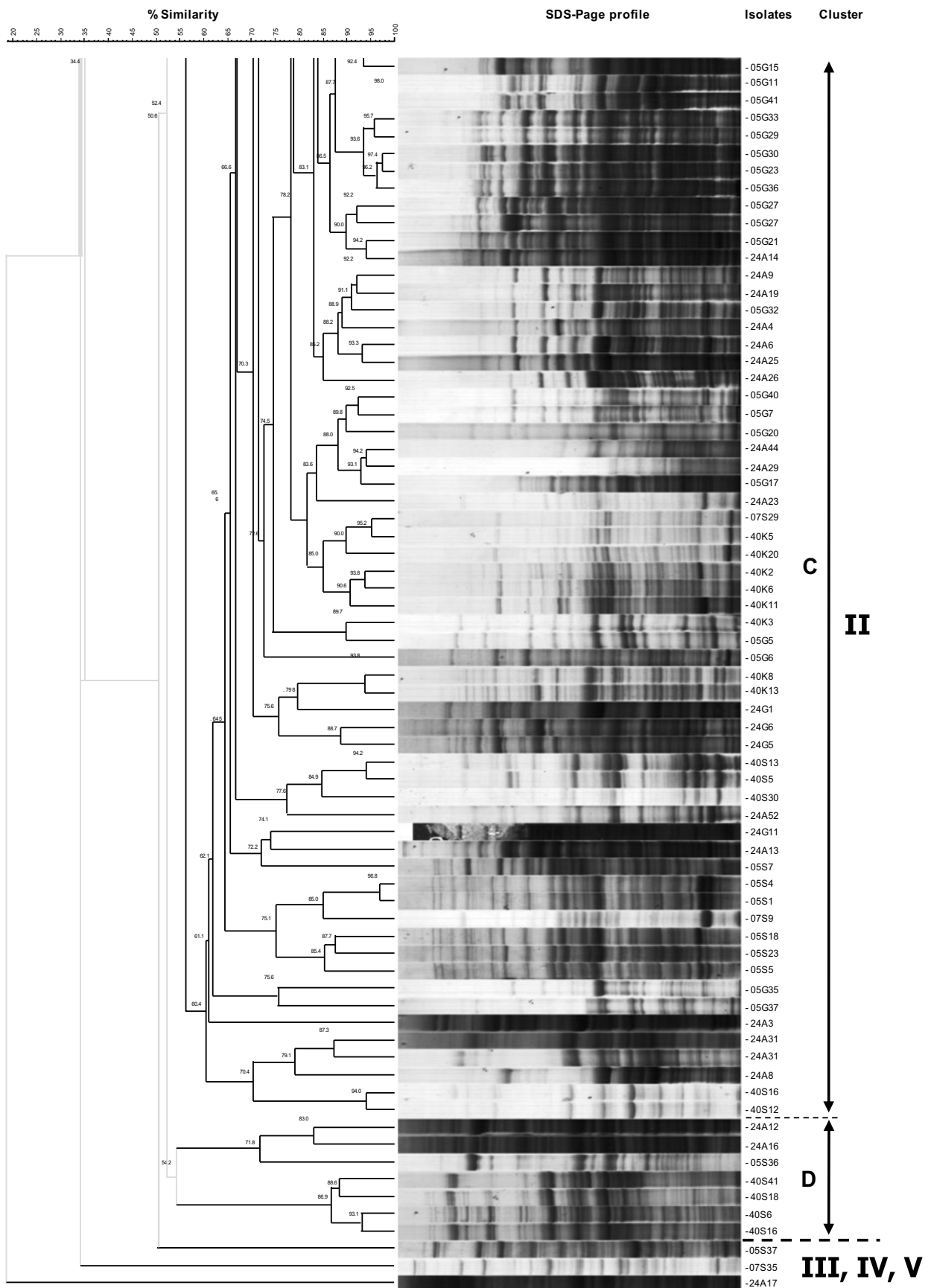

Fig. 2 continued.

**Table 1** Thermophilic bacteria isolated from Algerian hot springs and their best match results with 16S rRNA gene sequences of typed strains

Site	Genus	Isolates	Related bacterial strains (accession number)	Similarity (%)	
Guedjima Hot Spring (H05G) N = 15	<i>Aeribacillus</i> (n = 4)	05G38	<i>A. composti</i> N.8 (LT594972)	99.77	
		05G14	<i>A. pallidus</i> KCTC3564 (CP017703)	99.60	
		05G30	<i>A. pallidus</i> KCTC3564 (CP017703)	99.82	
		05G40	<i>A. pallidus</i> KCTC3564 (CP017703)	99.36	
	<i>Aneurinibacillus</i> (n = 4)	05G4	<i>A. thermoaerophilus</i> DSM 10154 (X94196)	99.82	
		05G7	<i>A. thermoaerophilus</i> DSM 10154 (X94196)	99.86	
		05G8	<i>A. thermoaerophilus</i> DSM 10154 (X94196)	99.72	
		05G9	<i>A. thermoaerophilus</i> DSM 10154 (X94196)	99.88	
	<i>Anoxybacillus</i> (n = 3)	05G21	<i>A. gonensis</i> G2 (CP012152)	99.22	
		05G27	<i>A. gonensis</i> G2 (CP012152)	99.81	
		05G37	<i>A. gonensis</i> G2 (CP012152)	100.0	
	<i>Bacillus</i> (n = 3)	05G33	<i>B. sonorensis</i> NBRC101234 (AYTN01000016)	99.78	
		05G32	<i>B. licheniformis</i> ATCC14580 (AE017333)	99.09	
		05G35	<i>B. licheniformis</i> ATCC14580 (AE017333)	99.71	
	Saïda Hot Spring (H05S) N = 13	<i>Thermoactinomyces</i> (n = 1)	05G17	<i>T. vulgaris</i> KCTC9076 (AF138739)	99.60
		<i>Aeribacillus</i> (n = 3)	05S4	<i>A. pallidus</i> KCTC3564 (CP017703)	99.71
			05S8	<i>A. pallidus</i> KCTC3564 (CP017703)	100.0
			05S20	<i>A. pallidus</i> KCTC3564 (CP017703)	99.30
		<i>Anoxybacillus</i> (n = 4)	05S29	<i>A. gonensis</i> G2 (CP012152)	99.65
05S32			<i>A. kaynarcensis</i> D1021 (EU926955)	99.14	
05S15			<i>A. pushchinoensis</i> K1 (jgi.1042845)	99.53	
05S24			<i>A. salavatliensis</i> A343 (EU326496)	99.70	
<i>Bacillus</i> (n = 1)		05S9	<i>B. hisashii</i> N-11 (AB618491)	99.40	
<i>Brevibacillus</i> (n = 1)		05S37	<i>B. aydinogluensis</i> PDF25 (HQ419073)	99.79	
<i>Meiothermus</i> (n = 1)		05S28	<i>M. ruber</i> DSM1279 (CP001743)	100.0	
<i>Thermoactinomyces</i> (n = 3)		05S3	<i>T. vulgaris</i> KCTC9076 (AF138739)	99.40	
		05S19	<i>T. vulgaris</i> KCTC9076 (AF138739)	99.62	
	05S21	<i>T. vulgaris</i> KCTC9076 (AF138739)	98.13		
Belhachani Hot Spring (H24A) N = 15	<i>Aeribacillus</i> (n = 3)	24A34	<i>A. composti</i> N.8 (LT594972)	99.93	
		24A13	<i>A. pallidus</i> KCTC3564 (CP017703)	99.50	
		24A52	<i>A. pallidus</i> KCTC3564 (CP017703)	99.08	
	<i>Anoxybacillus</i> (n = 4)	24A10	<i>A. flavithermus</i> DSM2641 (CP020815)	99.04	
		24A 3	<i>A. gonensis</i> G2 (CP012152)	99.63	
		24A46	<i>A. gonensis</i> G2 (CP012152)	99.81	
		24A12	<i>A. thermarum</i> AF/04 (AM402982)	99.28	
	<i>Bacillus</i> (n = 5)	24A37	<i>B. haynesii</i> NRRLB-41327 (MRBL01000076)	99.78	
		24A11	<i>B. kokeshiiformis</i> MO-04 (JX848633)	99.21	
		24A 6	<i>B. licheniformis</i> ATCC14580 (AE017333)	99.80	
		24A27	<i>B. licheniformis</i> ATCC14580 (AE017333)	99.47	
		24A31	<i>B. licheniformis</i> ATCC14580 (AE017333)	99.61	
	<i>Laceyella</i> (n = 1)	24A21	<i>L. sacchari</i> KCTC9790 (AF138737)	99.25	
	<i>Saccharomonospora</i> (n = 1)	24A43	<i>S. viridis</i> DSM43017 (CP001683)	99.36	
	<i>Thermoactinomyces</i> (n = 1)	24A22	<i>T. vulgaris</i> KCTC9076 (AF138739)	99.17	
	El Knif Hot Spring (H40K) N = 8	<i>Aneurinibacillus</i> (n = 4)	40K10	<i>A. thermoaerophilus</i> DSM 10154 (X94196)	99.88
			40K14	<i>A. thermoaerophilus</i> DSM 10154 (X94196)	99.65
40K15			<i>A. thermoaerophilus</i> DSM 10154 (X94196)	99.88	
40K18			<i>A. thermoaerophilus</i> DSM 10154 (X94196)	99.25	
<i>Anoxybacillus</i> (n = 2)		40K 8	<i>A. gonensis</i> G2 (CP012152)	99.03	
		40K12	<i>A. gonensis</i> G2 (CP012152)	99.31	

**Table 1** (continued)

Site	Genus	Isolates	Related bacterial strains (accession number)	Similarity (%)	
Essalihine Hot Spring (H40S) N = 15	<i>Bacillus</i> (n = 1)	40K 1	<i>B. licheniformis</i> ATCC14580 (AE017333)	99.11	
	<i>Brevibacillus</i> (n = 1)	40K19	<i>B. aydinogluensis</i> PDF25 (HQ419073)	99.28	
	<i>Aeribacillus</i> (n = 4)	40S28	<i>A. composti</i> N.8 (LT594972)	99.85	
		40S35	<i>A. composti</i> N.8 (LT594972)	99.85	
		40S30	<i>A. pallidus</i> KCTC3564 (CP017703)	99.56	
		40S42	<i>A. pallidus</i> KCTC3564 (CP017703)	99.24	
		<i>Aneurinibacillus</i> (n = 6)	40S14	<i>A. thermoaerophilus</i> DSM 10154 (X94196)	98.35
			40S16	<i>A. thermoaerophilus</i> DSM 10154 (X94196)	99.15
	40S23		<i>A. thermoaerophilus</i> DSM 10154 (X94196)	99.69	
	40S43		<i>A. thermoaerophilus</i> DSM 10154 (X94196)	99.41	
	40S44		<i>A. thermoaerophilus</i> DSM 10154 (X94196)	99.87	
	40S45		<i>A. thermoaerophilus</i> DSM 10154 (X94196)	99.88	
	Sidi El Hadj Hot Spring (H07S) N = 15	<i>Bacillus</i> (n = 2)	40S13	<i>B. haynesii</i> NRRLB-41327 (MRBL01000076)	99.78
			40S20	<i>B. licheniformis</i> ATCC14580 (AE017333)	99.61
		<i>Brevibacillus</i> (n = 3)	40S24	<i>B. aydinogluensis</i> PDF25 (HQ419073)	99.64
40S25			<i>B. thermoruber</i> DSM 7064 (Z26921)	99.54	
40S27			<i>B. thermoruber</i> DSM 7064 (Z26921)	96.81	
<i>Anoxybacillus</i> (n = 2)		07S31	<i>A. geothermalis</i> GSsed3 (KJ722458)	99.23	
		07S16	<i>A. gonensis</i> G2 (CP012152)	99.90	
		<i>Bacillus</i> (n = 11)	07S24	<i>B. haynesii</i> NRRLB-41327 (MRBL01000076)	99.35
			07S26	<i>B. haynesii</i> NRRLB-41327 (MRBL01000076)	99.78
			07S5	<i>B. hisashii</i> N-11 (AB618491)	99.88
			07S12	<i>B. hisashii</i> N-11 (AB618491)	99.90
			07S14	<i>B. hisashii</i> N-11 (AB618491)	99.52
			07S21	<i>B. hisashii</i> N-11 (AB618491)	99.77
			07S32	<i>B. hisashii</i> N-11 (AB618491)	99.51
			07S20	<i>B. licheniformis</i> ATCC14580 (AE017333)	96.09
07S27	<i>B. licheniformis</i> ATCC14580 (AE017333)	98.51			
07S13	<i>B. paralicheniformis</i> KJ-16 (KY694465)	99.73			
07S15	<i>B. paralicheniformis</i> KJ-16 (KY694465)	99.52			
<i>Brevibacillus</i> (n = 2)	07S11	<i>B. aydinogluensis</i> PDF25 (HQ419073)	99.77		
	07S35	<i>B. aydinogluensis</i> PDF25 (HQ419073)	99.48		
	Guerfa Hot Spring (H24G) N = 5	<i>Bacillus</i> (n = 3)	24G13	<i>B. haynesii</i> NRRLB-41327 (MRBL01000076)	99.50
24G 1			<i>B. hisashii</i> N-11 (AB618491)	99.40	
24G17			<i>B. sonorensis</i> NBRC101234 (AYTN01000016)	99.64	
<i>Geobacillus</i> (n = 2)		24G 6	<i>G. icigianus</i> G1w1 (KF631430)	98.02	
		24G 5	<i>G. stearothermophilus</i> NBRC 12550 (AB271757)	98.79	
Debagh Hot Spring (H24D) N = 14	<i>Aeribacillus</i> (n = 1)	24D35	<i>A. composti</i> N.8 (LT594972)	99.41	
	<i>Aneurinibacillus</i> (n = 1)	24D 1	<i>A. thermoaerophilus</i> DSM 10154 (X94196)	99.22	
	<i>Anoxybacillus</i> (n = 2)	24D20	<i>A. kaynarcensis</i> D1021 (EU926955)	99.41	
		24D29	<i>A. kaynarcensis</i> D1021 (EU926955)	99.49	
	<i>Bacillus</i> (n = 4)	24D46	<i>B. haynesii</i> NRRLB-41327 (MRBL01000076)	99.57	
		24D45	<i>B. hisashii</i> N-11 (AB618491)	99.47	
		24D 6	<i>B. kokeshiiformis</i> MO-04 (JX848633)	99.41	
		24D26	<i>B. thermocopriae</i> SgZ-7 (JX113681)	99.51	
		24D 3	<i>B. aydinogluensis</i> PDF25 (HQ419073)	99.56	
		<i>Brevibacillus</i> (n = 1)	24D 3	<i>B. aydinogluensis</i> PDF25 (HQ419073)	99.56
	<i>Meiothermus</i> (n = 2)		24D25	<i>M. ruber</i> DSM1279 (CP001743)	99.92
		24D28	<i>M. ruber</i> DSM1279 (CP001743)	98.98	
	<i>Thermobifida</i> (n = 1)	24D39	<i>T. fusca</i> NBRC14071 (BCWB01000075)	99.73	

**Table 1** (continued)

Site	Genus	Isolates	Related bacterial strains (accession number)	Similarity (%)
	<i>Thermus</i> (n = 2)	24D9	<i>T. antranikianii</i> HN3-7 (Y18411)	99.78
		24D24	<i>T. antranikianii</i> HN3-7 (Y18411)	99.23

amygdaline and inositol, 18% for mannitol, and 15% for glucose, sorbitol, and arabinose, respectively. Only 8% assimilate melibiose. The number of positive tests displayed by the isolates ranged from one to ten tests. Around 32% of strains were positive only for one character.

### Thermophilic bacterial diversity

Among the different sites, Debagh Hot Spring (H24D) and Belhachani Hot Spring (H24A) presented the highest species richness with its isolates being closely related to 11 genera. The second position of more diverse sites belonged to Saïda Hot Spring (H05S) with nine represented genera, followed by Guerdjima Hot Spring (H05G), Sidi El Hadj Hot Spring (H07S), and Essalihine Hot Spring (H40S) with seven genera for each site. Guerfa Hot Spring (H24G) and El Knif Hot Spring (H40K) resulted in five and four genera, respectively.

In the current study, the genus *Bacillus* (30%) was isolated from all sampled geothermal sites. A total of 7% of isolates represented by *Geobacillus*, *Laceyella*, *Saccharomonospora*, *Thermobifida*, and *Thermus* were uniquely distributed in the different hot springs. The other genera were distributed variably. *Aeribacillus*, *Aneurinibacillus*, *Anoxybacillus*, and *Brevibacillus* were isolated from five hot springs, while *Thermoactinomyces* and *Meiothermus* were cultured from three and two sites, respectively. At each sampling point of the four studied areas, we determined exclusive species (detected at a single sampling point) and common species (found in at least two sampling points). Venn diagram illustrates that Guelma's hot springs were more diverse than the other sites in terms of species exclusivity, hosting ten exclusive species. The analysis revealed that three species were shared among all locations, whereas one to four other species were classified as common species for the different combinations of regions (Fig. 6).

### Hydrolytic enzyme analysis

Bacterial isolates collected from hot springs were screened for amylase, cellulase, pectinase, esculinase, protease, gelatinase, lipase, lecithinase, and nuclease activities (Fig. S3). The frequency occurrence of nine hydrolytic extracellular enzymes produced by thermophilic bacteria at hot springs is shown in Fig. 7. A total of 143 isolates (48.81%) showed amylase activity, 156 isolates (53.24%) produced proteases, 122 isolates

(41.64%) produced lecithinase, 197 isolates (67.24%) reduced CMC-cellulose, 174 isolates (59.39%) produced pectinase enzyme, 200 isolates (68.26%) produce nuclease, 143 isolates (48.81%) produced esculinase, 189 isolates (64.50%) produce lipase, and 173 isolates produced (59.04%) gelatinase.

Among the 293 thermophilic bacteria, 99.32% produced at least one extracellular hydrolytic enzyme. The combined hydrolytic activity was also detected in most strains. Indeed, 19 isolates (6.48%) combined all tested enzymes. Jointly, 18.43% (54 isolates), 65.87% (42 isolates), and 15.36% (45 isolates) produced, respectively, four, five, and six hydrolytic enzymes simultaneously. In addition, 65.87% of bacterial isolates showed at least five enzymatic activities.

### Discussion

The present study searched for the diversity of thermophilic culturable bacteria in Algerian hot springs. Thermophilic bacteria were present in all analyzed samples, and the occurrence of isolates in different locations may be a result of the prevailing environmental conditions and the chemical properties of the water and sediment of the different hot springs, suggesting the environment selects those strains better thriving under those specific conditions, mainly temperature, pH, salinity, and mineral elements [60, 61]. Almost water and sediment allowed the isolation of a similar abundance of thermophilic bacteria. However, sediment samples presented higher diversity than water samples. Water samples showed more stable culturable communities, which were dominated by a low number of the most representative species. Microbial community composition and abundance of sediments are influenced by high nutrient content especially, organic matter, dissolved oxygen, nitrogen, and phosphorus levels, which are key factors causing differences in microbial community structure comparing to water [10, 62]. The number of thermophilic bacterial populations recovered was dependent on the media composition. Nutrient agar and Tryptic soy medium were employed for isolating a large proportion of the available diversity mainly the thermotolerant isolates; both media support the growth of bacteria from hot springs when incubated at high temperature [39]. Furthermore, *Thermus* medium, ATCC medium 697, and *Thermus* 162 medium were suitable for isolation of thermophilic bacteria, including novel species [63].

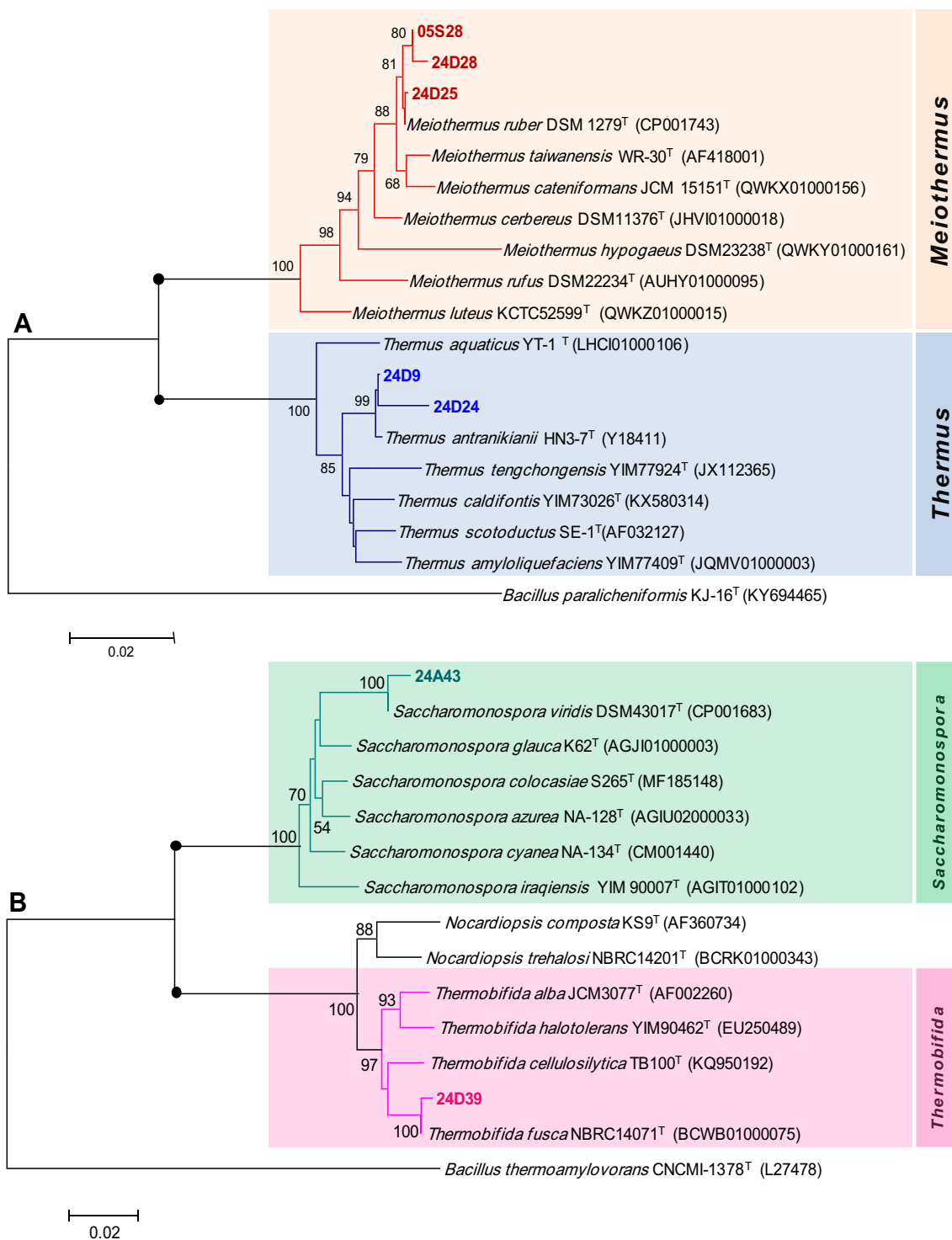

**Fig. 3** Neighbor-joining phylogenetic tree showing the relationship based on 16S rRNA gene sequence comparison of (a) *Deinococcus-Thermus* and (b) *Actinobacteria*. Bootstrap values (expressed as

percentages of 1000 replications) greater than 50% are shown at nodes. The scale bar represents 2% estimated sequence divergence. The sequence of *Bacillus thermoamylovorans* was used as an outgroup

There were very significant differences among the 293 presumptive thermophilic isolates in terms of morphological, biochemical, and physiological properties. Isolates had characteristic phenotypic characters; they were commonly Gram-positive rod-shaped cells, and they were generally oxidase-

and catalase-positive. Similarly, Narayan et al. reported the dominance of Gram-positive thermophilic bacteria from Savusavu hot Spring in Fiji [64].

Temperature tolerance of the isolates allowed their classification as thermophilic bacteria [1]. It has shown that 100%

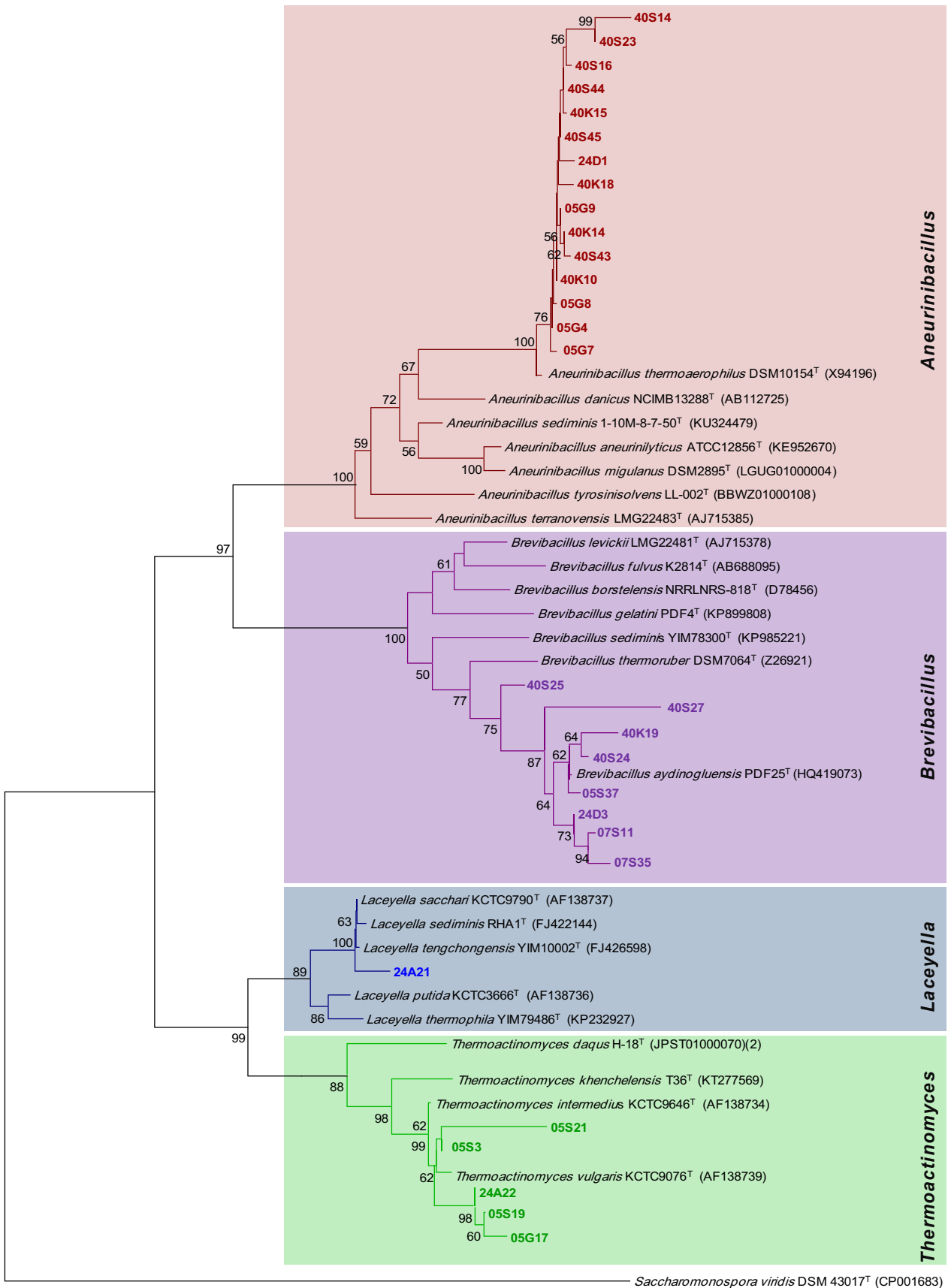

0.02

◀ **Fig. 4** Neighbor-joining phylogenetic tree showing the relationship between *Firmicutes* isolates (*Paenibacillaceae* and *Thermoactinomycetaceae*) and closely related species based on 16S rRNA gene sequence comparison. Bootstrap values expressed as percentages of 1000 replications; only bootstrap values > 50% are shown at nodes. The scale bar represents 2% estimated sequence divergence

of isolates grow variably at 55 °C. Although, around 50% of the bacteria can grow at 30 °C, but their optimal temperature was 55 °C, the same temperature of their isolation. A total of 128 isolates were moderately thermophilic, while 5.11% isolates were extremely or obligate thermophilic. Salt-tolerant range revealed that all the isolated strains were halotolerants [65]. The number of strains growing decreased at increasing salt. Almost all strains grew at near neutral to slightly alkaline pH ranging between 6.5 and 8.5. The physiological and morphological characteristics turned too difficult to differentiate isolates. This is well known and in accordance with previous microbiological descriptions [30].

The analysis of SDS-PAGE whole-cell protein patterns has proven to be highly reliable for comparing and clustering a large number of Gram-positive and negative mesophilic bacteria growing on identical conditions and belonging to different genera [66, 67]. However, there are very little researches about the application of this technique on thermophilic species. First, it was proved that thermophilic bacteria can be identified by their amino acid composition deduced from their complete genome sequences [33]. Later on, another research suggested that the whole protein profiles by SDS-PAGE of thermophilic bacteria isolated from deep-sea hydrothermal fields in the Pacific Ocean provide discrimination between species with high resolution [34]. Inan et al. [18] suggested the classification of strains belonging to the *Anoxybacillus* genus based on SDS profile. Both results showed great efficiency and rapidity in the differentiation of thermophilic species prior to further identification by genomics tools.

Based on SDS-PAGE fingerprinting of whole-cell protein results combined with physiological and biochemical data, of 293 isolates, 100 bacteria were selected for identification by complete 16S rDNA gene sequencing (~ 1400 bp). The *Bacillus* genus dominated the thermophilic isolates (30%) with high species diversity: *B. haynesii*, *B. hisashi*, *B. kokeshiiformis*, *B. licheniformis*, *B. paralicheniformis*, *B. sonorensis*, and *B. thermocopriae*. Other research found that *Bacillus* was the most dominant isolated genus [30, 38].

*Anoxybacillus* was ranked in second position (17%) with the following seven different species: *A. flavithermus*, *A. geothermalis*, *A. gonensis*, *A. kaynarcensis*, *A. pushchinoensis*, *A. salavatiensis*, and *A. thermarum*. The genera *Aeribacillus* and *Aneurinibacillus* presented 15% of the isolates. One genus with two species *A. composti* and *A. pallidus* and one species *A. thermoaerophilus* for the

second one. They were followed by *Brevibacillus* (8%), *Thermoactinomyces* (5%), and *Meiothermus* (3%) with two species *Brevibacillus aydinogluensis*, *Brevibacillus thermoruber*, and only one species *Thermoactinomyces vulgaris* and *Meiothermus ruber*, respectively. A low isolation rate of 2% characterized two genera *Geobacillus* represented by *Geobacillus icigianus* and *Geobacillus stearothermophilus*, with *Thermus* comprising one species *Thermus antranikianii*. Other species were also isolated, such as *Laceyella sacchari*, *Saccharomonospora viridis*, and *Thermobifida fusca*, representing 1% each of the total number of isolates. Yohandini et al. reported that the genera *Geobacillus*, *Anoxybacillus*, *Brevibacillus*, and *Bacillus* were the commonly found in thermal environments, within Tanjung Sakti Hot Spring, in South Sumatera, Indonesia, and these results are consistent with our findings [31]. Moreover, these results also indicate that Algerian hot springs located in the Eastern part of the country harbor a wide variety of thermophilic species, some already known or potentially novel waiting further identification. Interestingly, we notice the isolation and identification of strains belonging to six genera, *Aneurinibacillus*, *Laceyella*, *Meiothermus*, *Thermus*, *Thermobifida*, and *Saccharomonospora*, which have never been reported previously from any hot springs in Algeria [27, 28].

The members of *Firmicutes* dominated among the bacteria isolated from all sampled hot springs; the results provide evidence that *Bacillus* and related genera (*Aeribacillus*, *Anoxybacillus*, and *Geobacillus*) represent the family *Bacillaceae* with 64% of total isolates were ubiquitous. This is likely due to endospore-forming ability of these bacteria representing a successful survival strategy and dominance under high temperature conditions [68]. Similarly, many reports indicate the abundance of the phylum *Firmicutes* in extreme environments [9]. A total of 23% of *Firmicutes* were represented by *Paenibacillaceae* (*Aneurinibacillus* and *Brevibacillus*), following the finding by Kumar et al. [69]. Gram-negative bacteria were represented by the *Deinococcus-Thermus* phylum harboring *Meiothermus* and *Thermus*. Both genera have so far been isolated from terrestrial hot springs around the world [70, 71]. A reduced number of *Actinobacteria* was obtained. Two genera (*Thermobifida* and *Saccharomonospora*) were isolated from thermal spring sediments on the *Thermus* medium. Many researchers reported the actinobacterial diversity in hot springs by culture-independent methods. However, there are rare reports on culturable actinobacteria in geothermal fields [72].

Furthermore, six isolates exhibited < 98.51% nucleotide sequence similarity with reported type strains in the EzTaxon server. These values were lower than 98.65% 16S rRNA gene sequence similarity, threshold needed for differentiating two bacterial species, and to describe a new species without performing the DNA–DNA hybridization [73].

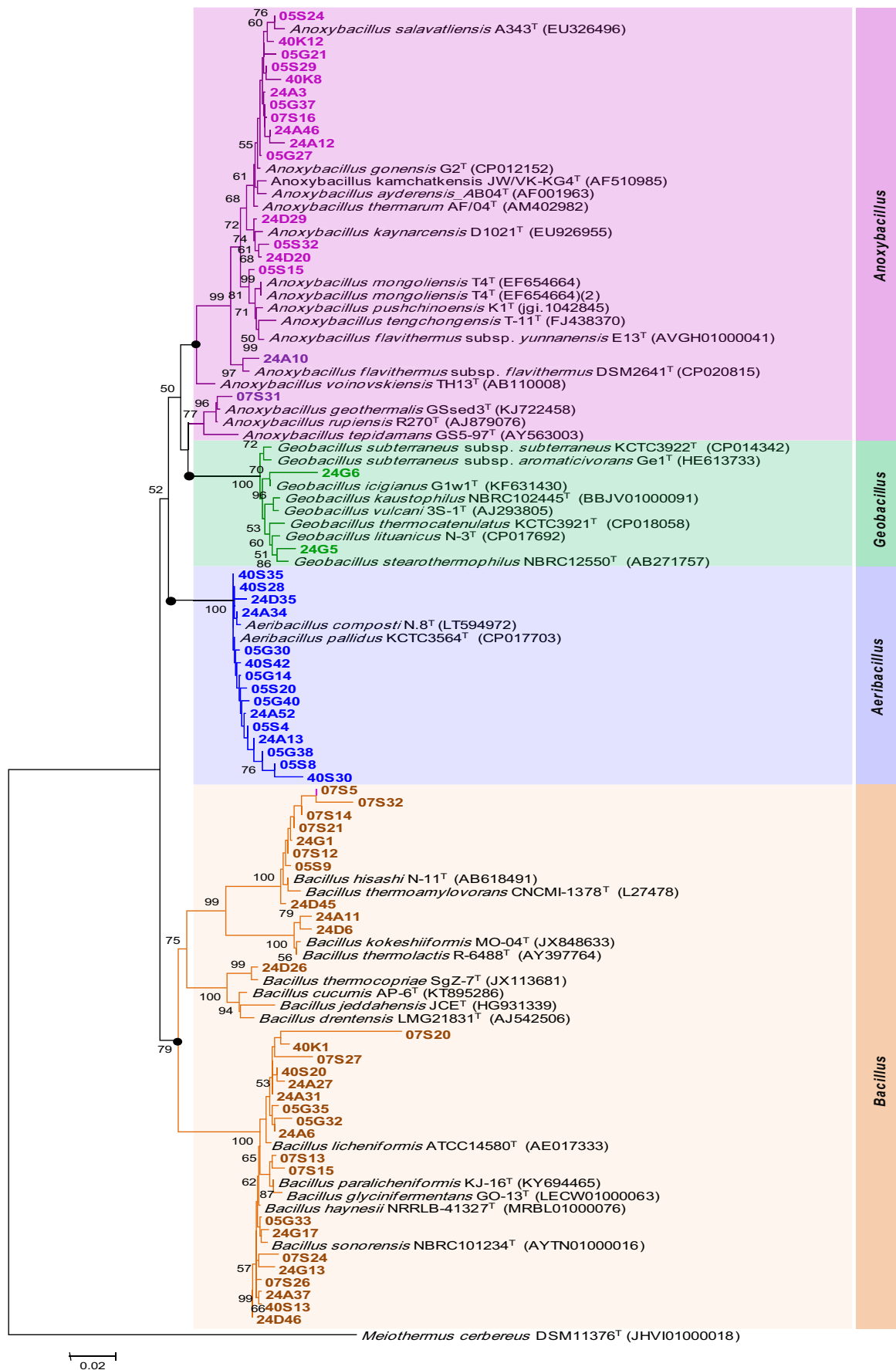

**Fig. 5** Neighbor-joining phylogenetic tree showing the relationship between *Bacillaceae* isolates and closely related species based on 16S rRNA gene sequence comparison. Bootstrap values expressed as percentages of 1000 replications; only bootstrap values > 50% are shown at nodes. The scale bar represents 2% estimated sequence divergence

Among the potentially novel strains, 07S20 and 07S27 showed sequence similarity with the type strain *Bacillus licheniformis* of 96.09 and 98.51%, respectively. The strain 40S27 indicated the highest sequence similarity with *Brevibacillus thermoruber* (96.81%). The two strains 24G6 and 24G5 exhibited 98.02 and 98.79% similarity with the species *Geobacillus icigianus* and *Geobacillus stearotherophilus*, respectively, while the strain 40S14 showed the highest 16S rRNA gene sequence similarity with the type strain *Aneurinibacillus thermoaerophilus* (98.35%), and the strain 05S21 revealed 98.13% sequence similarity with the species *Thermoactinomyces vulgaris*. These results indicate that they probably represent new species belonging to four different hot springs among the eight prospected, explaining the richness in new taxa of Algerian thermal springs. Previous studies describe novel species isolated from different Algerian terrestrial geothermal sites. Mainly represented by *Pyrococcus* sp. HT3, *Caldicoprobacter algeriensis*, and *Thermoactinomyces khenchelensis*, respectively [74–76].

The traditional methods, including morphological, physiological, and biochemical characterization, used for a preliminary classification of the isolates are troublesome, uncertain, difficult for interpretation, and may involve substantial subjective judgment [77]. At the same time, SDS-PAGE results allow clustering the isolates enabling rapid and easy discrimination as the first step for mandatory molecular identification. The 16S rRNA gene sequencing provides an important contribution to identifying the strains successfully to the genus

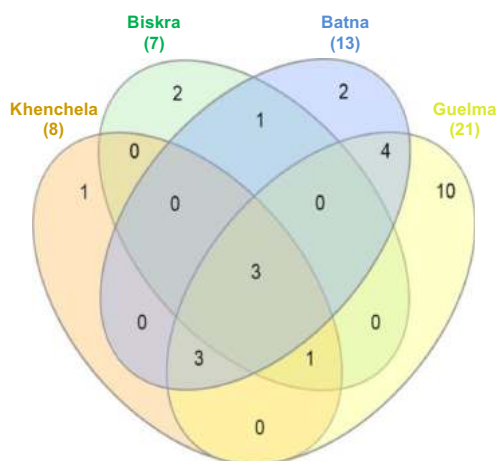

**Fig. 6** Venn diagram distribution illustrates the number of exclusive and common thermophilic bacterial isolates among the sampled sites. Each ellipse represents a sampling point

and sometimes even to species level. Although 16S rRNA gene sequencing is highly accurate and useful regarding bacterial classification, it may be insufficient to distinguish between some closely related species and has low discriminatory power for some genera [78]. This is the case for species within some genera, like *Bacillus*, *Anoxybacillus*, *Aeribacillus*, and *Geobacillus* [79–81]. Thus, the identification of bacteria, and specifically thermophiles, could benefit from the addition of other fingerprinting methods for strain and species discrimination [10, 18–82].

The limits of traditional culture-based methods to describe the enormous diversity existing in the hidden microbial world have forced to currently shift towards culture-independent approaches (i.e., based on DNA sequencing) which complement physiological analyses to explore functional and taxonomical diversity in hot springs [83].

The constructed UPGMA dendrogram of the biochemical characteristics of the selected 100 bacterial strains isolated from eight hot springs showed three clusters (numbered from I to III). Overall, all the isolates displayed a minimum similarity coefficient of approximately 0.68 or displayed phenotype profiles that were approximately 68% similar. A group of 14 isolates belonging to the eight hot springs formed cluster I. Three isolates from the sub-cluster (IA) showed identical biochemical profiles (isolates 05S28, 24D28, and 24D25 identified by 16S rDNA sequencing as *Meiothermus ruber*), same (isolates 07S13 and 07S15 identified as *Bacillus paralicheniformis*) from sub-cluster (IB), and cluster II was a mixture of 10 isolates from six different sites, exhibiting similar profiles for (40S24, 24D3, 05S37, and 07S35 attributed to *Brevibacillus aydinogluensis*). Finally, cluster III grouped 76 isolates into two sub-clusters, IIIA harboring six isolates and IIIB gathering 70 isolates. They corresponded to *Anoxybacillus gonensis*, *Geobacillus icigianus*, *Aneurinibacillus thermoaerophilus*, and *Brevibacillus aydinogluensis*. The biochemical characterization has certain limitations in the classification of isolates, as it is hard to distinguish closely related bacteria. Molecular identification is more reliable and could assist in definitive identification of isolates as part of a polyphasic taxonomic approach [84].

Thermophilic bacteria are expected to be a potential source of interesting hydrolytic enzymes with exceptional condition [1]. The present study revealed that the main enzyme producers were related to *Firmicutes* phylum (Fig. 7). Furthermore, nuclease, cellulase, lipase, and pectinase activities ranked in the first place of the common enzymes. Maybe due to the fact that the hot spring biotopes present a significant pool for special organic molecules inducing the bacterial enzymatic production [65]. Almost all the selected strains showed at least one extracellular enzyme among the tested activities, and 65.87% of bacterial isolates showed at least five combined enzymatic activities. The dominant isolates belonged to *Bacillus* and *Bacillus*-like genera, namely

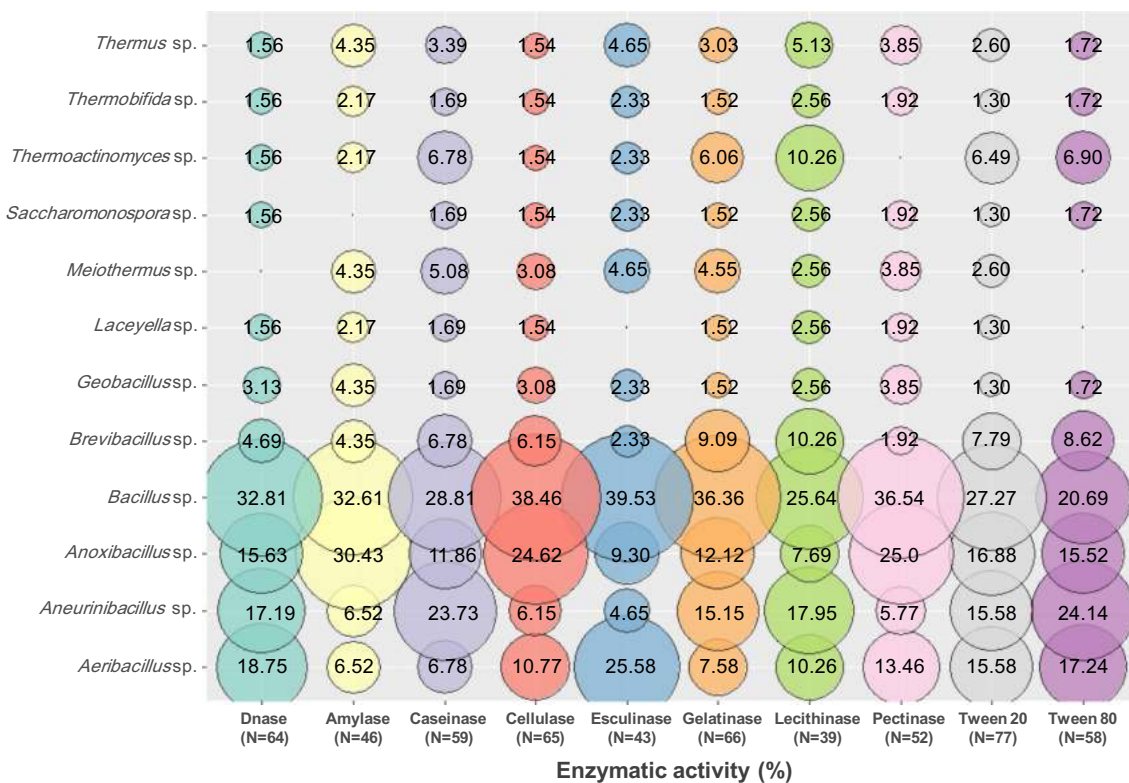

**Fig. 7** Distribution of extracellular hydrolytic enzymes among isolated thermophilic bacteria. *N*, the number of isolates presents activities for each enzyme

*Anoxybacillus*, *Aeribacillus*, and even *Aneurinibacillus* genus known for their significant production of enzymes [85, 86]. *Bacillus* sp. was the highest producer of all targeted enzymes ranging between 39.53 and 20.69%; indeed, *Bacillus* species are considered as workhorse industrial bacteria in applied and industrial microbiology due to the high rate of growth of these bacteria and their ability to secrete a large volume (20–25 g/L) of extracellular enzymes. Besides, most of these species are “generally regarded as safe” (GRAS) [87]. According to our findings, up to 28.81% of protease and 32.61% of amylase were produced by *Bacillus*. *Bacillus* proteases have several remarkable characteristics and make up approximately 60% of the total worldwide enzyme sales [88]. Different bacterial species can produce alpha-amylase, but for commercial applications; they mainly originated from the genus *Bacillus* [89]. Our results showed the highest rate of 30.43% for amylase activity produced by *Anoxybacillus* spp. (Fig. 7); from this genus, several new amylases with different properties were identified and characterized. Viksø-Nielsen et al. [90] reported a new  $\alpha$ -amylase that hydrolyzes raw starch granules.

Ecological studies on Algerian hot springs led to the isolation and identification of a large number of thermophilic bacteria capable of producing a mixture of hydrolytic enzymes that may be valuable for biotechnological purposes [28]. Extremophile microorganisms can thrive under extreme conditions of high temperature, salinity, pH, and pressure.

Particular interest on industrial applications of extremophiles emerges during the past few decades, because they are able to produce novel biocatalysts functioning under extreme conditions, resulting in unique products and higher production efficiency [65]. Thermozyms offer unique characteristics, such as temperature, chemical, and pH stability, resulting to technological interest in diverse industrial applications, including food, pharmaceutical, chemical, paper, textile processing, bio-fuel production, pulp, and waste treatment [91]. Consequently, thermophilic bacteria are a good source of novel catalysts suggesting new application or improving the existing processes of industrial interest [92].

## Conclusion

The present study aimed to analyze the culture-dependent diversity of thermophilic bacteria from terrestrial geothermal springs in Eastern-Algeria, using conventional taxonomic methods combined with molecular approaches. Interestingly, high taxonomic diversity was observed in Algerian hot springs, and several phylotypes, grouped as *Aneurinibacillus*, *Bacillus*, *Brevibacillus*, *Geobacillus*, and *Thermoactinomyces*, may constitute new taxa with novel hydrolytic potentials. Bacterial species diversity is a resource that can translate into novel biocatalysts. In fact, these

thermophilic isolates exhibit promising sources of hydrolytic extracellular enzymes serving various industrial, agricultural, and medicinal purposes, especially that present optimal activities at high temperatures.

### Compliance with ethical standards

**Conflict of interest** The authors declare that they have no conflict of interest.

### References

- Kumar S, Dangi AK, Shukla P, Baishya D, Khare SK (2019) Thermozymes: adaptive strategies and tools for their biotechnological applications. *Bioresour Technol* 278:372–382. <https://doi.org/10.1016/j.biortech.2019.01.088>
- Panda AK, Bisht SS, De Mandal S, Kumar NS (2018) Microbial diversity of thermophiles through the lens of next generation sequencing, *Microbial diversity in the genomic era*. Elsevier Inc
- Mahajan GB, Balachandran L (2017) Sources of antibiotics: hot springs. *Biochem Pharmacol* 134:35–41. <https://doi.org/10.1016/j.bcp.2016.11.021>
- Mehetre GT, Dastager SG, Dharme MS (2019) Biodegradation of mixed polycyclic aromatic hydrocarbons by pure and mixed cultures of biosurfactant producing thermophilic and thermo-tolerant bacteria. *Sci Total Environ* 679:52–60. <https://doi.org/10.1016/j.scitotenv.2019.04.376>
- Wang J, Salem DR, Sani RK (2019) Extremophilic exopolysaccharides: a review and new perspectives on engineering strategies and applications. *Carbohydr Polym* 205:8–26. <https://doi.org/10.1016/j.carbpol.2018.10.011>
- Ilyas S, Lee J, Kim B (2014) Bioremoval of heavy metals from recycling industry electronic waste by a consortium of moderate thermophiles: process development and optimization. *J Clean Prod* 70:194–202. <https://doi.org/10.3906/biy-1003-75>
- Rajkumari J, Bhuyan B, Das N, Pandey P (2019) Environmental applications of microbial extremophiles in the degradation of petroleum hydrocarbons in extreme environments. *Environ Sustain* 2: 311–328. <https://doi.org/10.1007/s42398-019-00065-1>
- Urbietta MS, Donati ER, Chan KG, Shahar S, Sin LL, Goh KM (2015) Thermophiles in the genomic era: biodiversity, science, and applications. *Biotechnol Adv* 33:633–647. <https://doi.org/10.1016/j.biotechadv.2015.04.007>
- Sahay H, Yadav AN, Singh AK, Singh S, Kaushik R, Saxena AK (2017) Hot springs of Indian Himalayas: potential sources of microbial diversity and thermostable hydrolytic enzymes. *3 Biotech* 7: 1–11
- Li L, Ma Z (2019) Global microbiome diversity scaling in hot springs with DAR (diversity-area relationship) profiles. *Front Microbiol* 10:118. <https://doi.org/10.3389/fmicb.2019.00118>
- Stone ET, Murray R, College H, Moran MD (2018) Microbial diversity in the thermal springs within Hot Springs National Park. 72:31–37. <https://scholarworks.uark.edu/jaas/vol72/iss1/9>. Accessed 12 April 2020
- Power JF, Carere CR, Lee CK, Evans DW, Button M, White D, Climo MD, Hinze AM, Morgan XC, McDonald IR, Cary SC, Stott MB (2018) Microbial biogeography of 1,000 geothermal springs in New Zealand. *Nat Commun* 9:2876. <https://doi.org/10.1101/247759>
- Narsing Rao MP, Liu L, Jiao JY, Xiao M, Li WJ (2018) Hot springs of India: occurrence and microbial diversity, pp 29–55. [https://doi.org/10.1007/978-981-13-0329-6\\_2](https://doi.org/10.1007/978-981-13-0329-6_2)
- Wilkins LGE, Ettinger CL, Jospin G, Eisen JA (2019) Metagenome-assembled genomes provide new insight into the microbial diversity of two thermal pools in Kamchatka, Russia. *Sci Rep* 9:1–15. <https://doi.org/10.1038/s41598-019-39576-6>
- Ward LM, Idei A, Terajima S, Kakegawa T, Fischer WW, McGlynn SE (2017) Microbial diversity and iron oxidation at Okuoku-hachikuro Onsen, a Japanese hot spring analog of Precambrian iron formations. *Geobiology* 15:817–835. <https://doi.org/10.1111/gbi.12266>
- Tang J, Liang Y, Jiang D, Li L, Luo Y, Shah MMR, Daroch M (2018) Temperature-controlled thermophilic bacterial communities in hot springs of western Sichuan, China. *BMC Microbiol* 18:1–14. <https://doi.org/10.1186/s12866-018-1271-z>
- Tobler DJ, Benning LG (2011) Bacterial diversity in five Icelandic geothermal waters: temperature and sinter growth rate effects. *Extremophiles* 15:473–485. <https://doi.org/10.1007/s00792-011-0378-z>
- Inan K, Çanakçı S, Beldü AO (2011) Isolation and characterization of xylanolytic new strains of *Anoxybacillus* from some hot springs in Turkey. *Turk J Biol* 35:529–542. <https://doi.org/10.3906/biy-1003-75>
- Saibi H (2009) Geothermal resources in Algeria. *Renew Sust Energy Rev* 13:2544–2552. <https://doi.org/10.1016/j.rser.2009.06.019>
- Stambouli AB, Khiat Z, Flazi S, Kitamura Y (2012) A review on the renewable energy development in Algeria: current perspective, energy scenario and sustainability issues. *Renew Sust Energy Rev* 16:4445–4460. <https://doi.org/10.1016/j.rser.2012.04.031>
- Boukhenfouf W, Boucenna A (2019) Comparison of the radioisotopic composition between hot spring water of Hammam Debagh and its associated deposits. *Radiat Prot Dosim* 187:369–377. <https://doi.org/10.1093/rpd/ncz177>
- Fekraoui A, Kedaid F (2005) Geothermal resources and uses in Algeria: a country update report. *Proc World Geothermal Congress:24–29*. <https://doi.org/10.1037/10320-002>
- Liang J, Kang D, Wang Y, Yu Y, Fan J, Takashi E (2015) Carbonate ion-enriched hot spring water promotes skin wound healing in nude rats. *PLoS One* 10:e0117106. <https://doi.org/10.1371/journal.pone.0117106>
- Amarouche-Yala S, Benouadah A, El Ouahab BA, Moulla AS, Ouarezki SA, Azbouche A (2015) Physicochemical, bacteriological, and radiochemical characterization of some Algerian thermal spring waters. *Water Qual Expo Health* 7:233–249. <https://doi.org/10.1007/s12403-014-0130-x>
- Benamar L, Menasria T, Chergui A, Benfiala S, Ayachi A (2017) Indoor fungal contamination of traditional public baths (Hammams). *Int Biodeterior Biodegrad* 117:115–122. <https://doi.org/10.1016/j.ibiod.2016.12.004>
- Ait Ouali A, Issaadi A, Maizi D, Ayadi A, Bouhdjar A (2019) Geothermal potential in the Ouarsenis-Biban-Kabylie (North Central Algeria): hot spring catalogue. *Arab J Geosci* 12:741. <https://doi.org/10.1007/s12517-019-4945-4>
- Arab M, Bakour S, Lalaoui R, Aissaoui N, Nas F, Hoceini A, Fournier P, Klouche-khelil N (2018) Diversity of aerobic bacilli analysis using molecular and culture-based approaches in Debagh hot spring diversity of aerobic bacilli analysis using molecular and culture-based. *Geomicrobiol J* 36:1–11. <https://doi.org/10.1080/01490451.2018.1520937>
- Gomri MA, Khaldi TEM, Kharroub K (2018) Analysis of the diversity of aerobic, thermophilic endospore-forming bacteria in two Algerian hot springs using cultural and non-cultural methods. *Ann Microbiol* 68:915–929. <https://doi.org/10.1007/s13213-018-1401-8>
- Kuisene N, Emantene R, Valiunas D, Chitavichus D (2002) Characterization of thermophilic spore-forming bacteria from a geothermal spring in Lithuania based on 16S rDNA and 16S-23S rDNA intergenic spacers analyses. *Mikrobiologija* 71:824–828

30. Aanniz T, Ouadghiri M, Melloul M, Swings J, Elfahime E, Ibjibjen J, Ismaili M, Amar M (2015) Thermophilic bacteria in Moroccan hot springs, salt marshes and desert soils. *Braz J Microbiol* 46:443–453. <https://doi.org/10.1590/S1517-838246220140219>
31. Yohandini H, Julinar M (2015) Isolation and phylogenetic analysis of thermophile community within Tanjung Sakti Hot Spring, South Sumatera, Indonesia. *HAYATI J Biosci* 22:143–148. <https://doi.org/10.1016/j.hjb.2015.10.006>
32. Ming H, Ji WL, Li S, Zhao ZL, Zhan LY, Meng XL, Zhou EM, Nie GX, Li WJ (2017) *Laceyella thermophila* sp. nov., a thermophilic bacterium isolated from a hot spring. *Int J Syst Evol Microbiol* 67:2953–2958. <https://doi.org/10.1099/ijsem.0.002057>
33. Kreil DP, Ouzounis CA (2001) Identification of thermophilic species by the amino acid compositions deduced from their genomes. *Nucleic Acids Res* 29:1608–1615. <https://doi.org/10.1093/nar/29.7.1608>
34. Liu B, Li H, Wu S, Zhang X, Xie L (2006) A simple and rapid method for the differentiation and identification of thermophilic bacteria. *Can J Microbiol* 52:753–758. <https://doi.org/10.1139/w06-036>
35. Brock TD, Freeze H (1969) *Thermus aquaticus* gen. n. and sp. n., a nonsporulating extreme thermophile. *J Bacteriol* 98:289–297
36. Degryse E, Glansdorff N, Piérard A (1978) A comparative analysis of extreme thermophilic bacteria belonging to the genus *Thermus*. *Arch Microbiol* 117:189–196. <https://doi.org/10.1007/BF00402307>
37. Oshima T, Imahori K (1974) Description of *Thermus thermophilus* (Yoshida and Oshima) comb. nov., a nonsporulating thermophilic bacterium from a Japanese thermal spa. *Int J Syst Bacteriol* 24:102–112. <https://doi.org/10.1099/00207713-24-1-102>
38. Adiguzel A, Ozkan H, Baris O, Inan K, Gulluce M, Sahin F (2009) Identification and characterization of thermophilic bacteria isolated from hot springs in Turkey. *J Microbiol Methods* 79:321–328. <https://doi.org/10.1016/j.mimet.2009.09.026>
39. Arya M, Joshi GK, Gupta AK, Kumar A, Raturi A (2015) Isolation and characterization of thermophilic bacterial strains from Soldhar (Tapovan) hot spring in Central Himalayan Region, India. *Ann Microbiol* 65:1457–1464. <https://doi.org/10.1007/s13213-014-0984-y>
40. Murray RGE, Doetsch RN, Robinow CF (1994) Determinative and cytological light microscopy. In: Gerhardt P, Murray RGE, Wood WA, Krieg NR (eds) *Methods for general and molecular bacteriology*. American Society for Microbiology, Washington, DC, pp 21–41
41. Gregersen T (1978) Method for the distinction of Gram-negative from Gram-positive bacteria. *Eur J Appl Microbiol* 5:123–127. <https://doi.org/10.1007/BF01385437>
42. Maugeri TL, Gugliandolo C, Caccamo D, Stackebrandt E (2001) A polyphasic taxonomic study of thermophilic bacilli from shallow, marine vents. *Syst Appl Microbiol* 24:572–587. <https://doi.org/10.1078/0723-2020-00054>
43. Munster MJ, Munster AP, Woodrow JR, Sharp RJ (1986) Isolation and preliminary taxonomic studies of *Thermus* strains isolated from Yellowstone National Park, USA. *Microbiology* 132:1677–1683. <https://doi.org/10.1099/00221287-132-6-1677>
44. Belduz AO, Dulger S, Demirbag Z (2003) *Anoxybacillus gonensis* sp. nov., a moderately thermophilic, xylose-utilizing, endospore-forming bacterium. *Int J Syst Evol Microbiol* 53:1315–1320. <https://doi.org/10.1099/ijms.0.02473-0>
45. Laemmli UK (1970) Cleavage of structural proteins during the assembly of the head of bacteriophage T4. *Nature* 227:680–685. <https://doi.org/10.1038/227680a0>
46. Chun J, Lee JH, Jung Y, Kim M, Kim S, Kim BK, Lim YW (2007) EzTaxon: a web-based tool for the identification of prokaryotes based on 16S ribosomal RNA gene sequences. *Int J Syst Evol Microbiol* 57:2259–2261. <https://doi.org/10.1099/ijms.0.64915-0>
47. Tamura K, Stecher G, Peterson D, Filipiński A, Kumar S (2013) MEGA6: molecular evolutionary genetics analysis version 6.0. *Mol Biol Evol* 30:2725–2729. <https://doi.org/10.1093/molbev/mst197>
48. Saitou N, Nei M (1987) The neighbor-joining method: a new method for reconstructing phylogenetic trees. *Mol Biol Evol* 4:406–425. <https://doi.org/10.1093/oxfordjournals.molbev.a040454>
49. Marteinson VT, Birrien JL, Jeanthon C, Prieur D (1996) Numerical taxonomic study of thermophilic *Bacillus* isolated from three geographically separated deep-sea hydrothermal vents. *FEMS Microbiol Ecol* 21:255–266. [https://doi.org/10.1016/S0168-6496\(96\)00061-X](https://doi.org/10.1016/S0168-6496(96)00061-X)
50. Kasana RC, Salwan R, Dhar H, Dutt S, Gulati A (2008) A rapid and easy method for the detection of microbial cellulases on agar plates using Gram's iodine. *Curr Microbiol* 57:503–507. <https://doi.org/10.1007/s00284-008-9276-8>
51. Atlas RM (2005) *Handbook of media for environmental microbiology*, 2nd edn. CRC Press, Taylor & Francis Group
52. Soares MMCN, Da Silva R, Gomes E (1999) Screening of bacterial strains for pectinolytic activity: characterization of the polygalacturonase produced by *Bacillus* sp. *Rev Microbiol* 30:299–303. <https://doi.org/10.1590/S0001-37141999000400002>
53. Nabi N, Chaouachi M, Zellama MS, Ben Hafsa A, Mrabet B, Saïd K, Fathia HS (2016) A new QRT-PCR assay designed for the differentiation between elements provided from *Agrobacterium* sp. in GMOs plant events and natural *Agrobacterium* sp. bacteria. *Food Chem* 196:58–65. <https://doi.org/10.1016/j.foodchem.2015.09.015>
54. White D, Sharp RJ, Priest FG (1994) A polyphasic taxonomic study of thermophilic bacilli from a wide geographical area. *Antonie Van Leeuwenhoek* 64:357–386. <https://doi.org/10.1007/BF00873093>
55. Frazier WC (1926) A method for the detection of changes in gelatin due to bacteria. *J Infect Dis* 39:302–309. <https://doi.org/10.1093/infdis/39.4.302>
56. Gopinath SCB, Anbu P, Hilda A (2005) Extracellular enzymatic activity profiles in fungi isolated from oil-rich environments. *Mycoscience* 46:119–126. <https://doi.org/10.1007/s10267-004-0221-9>
57. Sierra G (1957) A simple method for the detection of lipolytic activity of micro-organisms and some observations on the influence of the contact between cells and fatty substrates. *Antonie Van Leeuwenhoek* 23:15–22. <https://doi.org/10.1007/BF02545855>
58. Priest FG, Goodfellow M, Todd C (1988) A numerical classification of the genus *Bacillus*. *Microbiology* 134:1847–1882. <https://doi.org/10.1099/00221287-134-7-1847>
59. Elder BL, Trujillo I, Blazevic DJ (1977) Rapid deoxyribonuclease test with methyl green. *J Clin Microbiol* 6:312–313
60. Magurran AE (2004) *Measuring biological diversity*. Wiley-Blackwell, Oxford
61. Cuecas A, Portillo MC, Kanoksilapatham W, Gonzalez JM (2014) Bacterial distribution along a 50 °C temperature gradient reveals a parceled out hot spring environment. *Microb Ecol* 68:729–739. <https://doi.org/10.1007/s00248-014-0437-y>
62. Pala C, Molari M, Nizzoli D, Bartoli M, Viaroli P, Manini E (2018) Environmental drivers controlling bacterial and archaeal abundance in the sediments of a Mediterranean lagoon ecosystem. *Curr Microbiol* 75:1147–1155. <https://doi.org/10.1007/s00284-018-1503-3>
63. Inan K, Ozer A, Guler HI et al (2016) *Brevibacillus gelatini* sp. nov., isolated from a hot spring. *Int J Syst Evol Microbiol* 66:712–718. <https://doi.org/10.1099/ijsem.0.00078>
64. Narayan VV, Hatha MA, Morgan HW, Rao D (2008) Isolation and characterization of aerobic thermophilic bacteria from the Savusavu Hot Springs in Fiji. *Microbes Environ* 23:350–352. <https://doi.org/10.1264/jsm2.ME08105>

65. Menasria T, Monteoliva-Sánchez M, Benammar L, Benhadj M, Ayachi A, Hacène H, Gonzalez-Paredes A, Aguilera M (2019) Culturable halophilic bacteria inhabiting Algerian saline ecosystems: a source of promising features and potentialities. *World J Microbiol Biotechnol* 35:132. <https://doi.org/10.1007/s11274-019-2705-y>
66. Eribe ERK, Olsen I (2002) SDS-PAGE of whole-cell proteins and random amplified polymorphic DNA (RAPD) analyses of *Leptotrichia* isolates. *Microb Ecol Health Dis* 14:193–202. <https://doi.org/10.1080/08910600310002073>
67. Kim TW, Kim YH, Kim SE, Lee JH, Park CS, Kim HY (2010) Identification and distribution of *Bacillus* species in Doenjang by whole-cell protein patterns and 16S rRNA gene sequence analysis. *J Microbiol Biotechnol* 20:1210–1214. <https://doi.org/10.4014/jmb.1002.02008>
68. Nicholson WL, Munakata N, Horneck G, Melosh HJ, Setlow P (2000) Resistance of *Bacillus* endospores to extreme terrestrial and extraterrestrial environments. *Microbiol Mol Biol Rev* 64:548–572. <https://doi.org/10.1128/membr.64.3.548-572.2000>
69. Kumar M, Yadav AN, Tiwari R, Prasanna R, Saxena AK (2014) Deciphering the diversity of culturable thermotolerant bacteria from Manikaran hot springs. *Ann Microbiol* 64:741–751. <https://doi.org/10.1007/s13213-013-0709-7>
70. Spanevello MD, Patel BKC (2004) The phylogenetic diversity of *Thermus* and *Meiothermus* from microbial mats of an Australian subsurface aquifer runoff channel. *FEMS Microbiol Ecol* 50:63–73. <https://doi.org/10.1016/j.femsec.2004.05.008>
71. Tindall BJ, Sikorski J, Lucas S, Goltsman E, Copeland A, Glavina del Rio T, Nolan M, Tice H, Cheng JF, Han C, Pitluck S, Liolios K, Ivanova N, Mavromatis K, Ovchinnikova G, Pati A, Fährnich R, Goodwin L, Chen A, Palaniappan K, Land M, Hauser L, Chang YJ, Jeffries CD, Rohde M, Göker M, Woyke T, Bristow J, Eisen JA, Markowitz V, Hugenholtz P, Kyrpides NC, Klenk HP, Lapidus A (2010) Complete genome sequence of *Meiothermus ruber* type strain (21T). *Stand Genomic Sci* 3:26–36. <https://doi.org/10.4056/sigs.1032748>
72. Liu L, Salam N, Jiao JY, Jiang HC, Zhou EM, Yin YR, Ming H, Li WJ (2016) Diversity of culturable thermophilic actinobacteria in hot springs in Tengchong, China and studies of their biosynthetic gene profiles. *Microb Ecol* 72:150–162. <https://doi.org/10.1007/s00248-016-0756-2>
73. Kim M, Oh HS, Park SC, Chun J (2014) Towards a taxonomic coherence between average nucleotide identity and 16S rRNA gene sequence similarity for species demarcation of prokaryotes. *Int J Syst Evol Microbiol* 64:346–351. <https://doi.org/10.1099/ijs.0.059774-0>
74. Kecha M, Benallaoua S, Touzel JP, Bonaly R, Duchiron F (2007) Biochemical and phylogenetic characterization of a novel terrestrial hyperthermophilic archaeon pertaining to the genus *Pyrococcus* from an Algerian hydrothermal hot spring. *Extremophiles* 11:65–73. <https://doi.org/10.1007/s00792-006-0010-9>
75. Bouanane-Darenfed A, Fardeau ML, Grégoire P, Joseph M, Kebbouche-Gana S, Benayad T, Hacene H, Cayol JL, Ollivier B (2011) *Caldicoprobacter algeriensis* sp. nov. a new thermophilic anaerobic, xylanolytic bacterium isolated from an Algerian hot spring. *Curr Microbiol* 62:826–832. <https://doi.org/10.1007/s00284-010-9789-9>
76. Mokrane S, Bouras N, Meklat A, Lahoum A, Zitouni A, Verheeecke C, Mathieu F, Schumann P, Spröer C, Sabaou N, Klenk HP (2016) *Thermoactinomyces khenchelensis* sp. nov., a filamentous bacterium isolated from soil sediment of a terrestrial hot spring. *Antonie van Leeuwenhoek*. *Int J Gen Mol Microbiol* 109:311–317. <https://doi.org/10.1007/s10482-015-0634-9>
77. Tang YW, Ellis NM, Hopkins MK, Smith DH, Dodge DE, Persing DH (1998) Comparison of phenotypic and genotypic techniques for identification of unusual aerobic pathogenic gram-negative bacilli. *J Clin Microbiol* 36:3674–3679. <https://doi.org/10.1128/JCM.36.12.3674-3679.1998>
78. Janda JM, Abbott SL (2007) 16S rRNA gene sequencing for bacterial identification in the diagnostic laboratory: pluses, perils, and pitfalls. *J Clin Microbiol* 45:2761–2764. <https://doi.org/10.1128/JCM.01228-07>
79. Zeigler DR, Perkins JB (2008) The genus *Bacillus*. In: Goldman E, Green LH (eds) *Practical handbook of microbiology*, 2nd edn. CRC Press, New York, pp 309–337
80. Goh KM, Gan HM, Chan KG, Chan GF, Shahar S, Chong CS, Kahar UM, Chai KP (2014) Analysis of *Anoxybacillus* genomes from the aspects of lifestyle adaptations, prophage diversity, and carbohydrate metabolism. *PLoS One* 9:e90549. <https://doi.org/10.1371/journal.pone.0090549>
81. Burgess SA, Flint SH, Lindsay D, Cox MP, Biggs PJ (2017) Insights into the *Geobacillus stearothermophilus* species based on phylogenomic principles. *BMC Microbiol* 17:1–12. <https://doi.org/10.1186/s12866-017-1047-x>
82. Colak DN, Inan K, Karaoglu H, Canakci S, Belduz AO (2012) Molecular analysis of the genus *Anoxybacillus* based on sequence similarity of the genes *recN*, *flaA*, and *ftsY*. *Folia Microbiol (Praha)* 57:61–69. <https://doi.org/10.1007/s12223-011-0094-1>
83. Panda AK, Bisht SS, De Mandal S, Kumar NS (2018) Microbial diversity of thermophiles through the lens of next generation sequencing. Elsevier Inc.
84. Singh AK, Tripathi BM, Sahay H, Singh RN, Kaushik R, Saxena AK, Arora DK (2010) Biochemical and molecular characterization of thermo-alkali tolerant xylanase producing bacteria from thermal springs of Manikaran. *Indian J Microbiol* 50:2–9. <https://doi.org/10.1007/s12088-010-0071-4>
85. Goh KM, Kahar UM, Chai YY, Chong CS, Chai KP, Ranjani V, Ilias RM, Chan KG (2013) Recent discoveries and applications of *Anoxybacillus*. *Appl Microbiol Biotechnol* 97:1475–1488. <https://doi.org/10.1007/s00253-012-4663-2>
86. Menasria T, Aguilera M, Hocine H, Benammar L, Ayachi A, Si Bachir A, Dekak A, Monteoliva-Sánchez M (2018) Diversity and bioprospecting of extremely halophilic archaea isolated from Algerian arid and semi-arid wetland ecosystems for halophilic-active hydrolytic enzymes. *Microbiol Res* 207:289–298. <https://doi.org/10.1016/j.micres.2017.12.011>
87. Schallmey M, Singh A, Ward OP (2004) Developments in the use of *Bacillus* species for industrial production. *Can J Microbiol* 50:1–17. <https://doi.org/10.1139/w03-076>
88. Contesini FJ, de Melo RR, Sato HH (2018) An overview of *Bacillus* proteases: from production to application. *Crit Rev Biotechnol* 38:321–334. <https://doi.org/10.1080/07388551.2017.1354354>
89. de Souza PM, de Oliveira MP (2010) Application of microbial  $\alpha$ -amylase in industry—a review. *Braz J Microbiol* 41:850–861. <https://doi.org/10.1590/s1517-83822010000400004>
90. Viksø-Nielsen A, Andersen C, Hoff T, Pedersen S (2006) Development of new  $\alpha$ -amylases for raw starch hydrolysis. *Biocatal Biotransform* 24:121–127. <https://doi.org/10.1080/10242420500519191>
91. Han H, Ling Z, Khan A, Virk AK, Kulshrestha S, Li X (2019) Improvements of thermophilic enzymes: from genetic modifications to applications. *Bioresour Technol* 279:350–361. <https://doi.org/10.1016/j.biortech.2019.01.087>
92. Niehaus F, Bertoldo C, Kähler M, Antranikian G (1999) Extremophiles as a source of novel enzymes for industrial application. *Appl Microbiol Biotechnol* 51:711–729. <https://doi.org/10.1007/s002530051456>